

Dosing pump Series – PHL

- Maximum Flow rate: 7000 l/h • Maximum Pressure: 65 kg/cm²g • hydraulically actuated diaphragm
- Conforms to API-675 Standard

Technical characteristics

- Flow rate up to (Both Metallic/Plastic):
 - 3500 l/h for PHL Simplex pump @ 5 kg/cm² g
 - 7000 l/h for PHL Duplex pump @ 5 kg/cm² g
- Pressure up to:
 - 65 kg/cm² g for PHL Simplex/Duplex metallic liquid end
 - 10 kg/cm² g for PHL Simplex/Duplex plastic liquid end
- Maximum temperature of pumped liquid:
 - +80 °C for metallic liquid end
 - +45 °C for plastic liquid end
- Manual or automatic flow control, adjustment of flow rate while running or stopped: from 0 to 100%
- High-efficiency, hydraulically actuated PTFE diaphragm for long life and high precision check valves for reliable sealing
- Steady state accuracy ±1% of the rated capacity
- Repeatability ±3% of the rated capacity
- Turndown ratio 10:1
- Viscosity handled: upto 2400 cps
- Lockable micrometer stroke adjustment.
- End connections available in both threaded/flanged versions
- Diaphragm Rupture Detection System (DRDS)

Options:

- Variable speed drive, Electronic capacity controller, Pneumatic actuator.
- DRDS with pressure gauge is standard. Pressure switch/transmitter is optional.

Characteristics of motors

Standard Motor Data:

- Power Supply: 415V – 50 Hz – 3 phases
- Degree of protection: IP 55, class F
- Motor Speed: 1500 rpm for 150 SPM
- Motor Speed: 1000 rpm for 100 & 120 SPM
- Enclosure: TEFC, IE2.

Options:

- Flame/Explosion proof motors

Accessories

To meet your installation needs a large range of accessories are available on request (Pulsation dampeners, safety and back pressure valves), consult us.



PHL - Metallic Liquid End

Liquid end construction

Components	Materials	
Model	PHL (Metallic Liquid End)	PHL (Plastic Liquid End)
Head	CF8M	PP
Check Valve	SS316 / CF8M	PVC
Balls	SS-316	GLASS / DVC / Teflon
Diaphragm	TFN*	TFN*

Note:

1. TFN* - Teflon Faced Nitrile
2. Alloy20, SS316L are the MOC options available for liquid end. Contact company for more details.

Performances PHL Pump (Simplex - Metallic Liquid End)

Pump Model	Piston Φ (mm)	Stroke Speed (SPM)	Flow (LPH)	Pressure (Kg/Cm2(g))			End Connection	Diaphragm Size
				2 HP	3 HP	5 HP		
PHL 40A	40	100	350	50.0	65.0	--	1" BSP(M)	166
PHL 40B	40	120	400	40.0	65.0	--		
PHL 40C	40	150	500	32.0	50.0	65.0		
PHL 50A	50	100	525	32.0	40.0	--		
PHL 50B	50	120	640	25.0	40.0	--		
PHL 50C	50	150	800	20.0	32.0	40.0		
PHL 63A	63	100	835	20.0	25.0	--		
PHL 63B	63	120	1050	16.0	25.0	--		
PHL 63C	63	150	1300	12.0	20.0	25.0		
PHL 70A	70	100	1000	16.0	20.0	--	1-1/2"BSP(M)	266
PHL 70B	70	120	1300	13.0	20.0	--		
PHL 70C	70	150	1600	10.0	16.0	20.0		
PHL 80A	80	100	1400	10.0	15.0	--		
PHL 80B	80	120	1700	8.0	15.0	--		
PHL 80C	80	150	2100	6.0	9.0	15.0		
PHL 90A	90	100	1800	7.0	10.0	--		
PHL 90B	90	120	2100	6.0	10.0	--		
PHL 90C	90	150	2700	5.0	8.0	10.0		
PHL 100A	100	100	2200	5.0	7.0	--		
PHL 100B	100	120	2600	5.0	7.0	--		
PHL 115A	115	100	2900	--	5.0	--		
PHL 115B	115	120	3500	--	5.0	--		

Performances PHL Pump (Simplex - Metallic Liquid End) With DRDS

Pump Model	Piston Φ (mm)	Stroke Speed (SPM)	Flow (LPH)	Pressure (Kg/Cm2(g))			End Connection	Diaphragm Size
				2 HP	3 HP	5 HP		
PHL 40AD	40	100	330	50.0	65.0	--	1" BSP(M)	166
PHL 40BD	40	120	380	40.0	65.0	--		
PHL 40CD	40	150	475	32.0	50.0	65.0		
PHL 50AD	50	100	495	32.0	40.0	--		
PHL 50BD	50	120	608	25.0	40.0	--		
PHL 50CD	50	150	760	20.0	32.0	40.0		
PHL 63AD	63	100	790	20.0	25.0	--		
PHL 63BD	63	120	995	16.0	25.0	--		
PHL 63CD	63	150	1235	12.0	20.0	25.0		
PHL 70AD	70	100	950	16.0	20.0	--	1-1/2"BSP(M)	266
PHL 70BD	70	120	1235	13.0	20.0	--		
PHL 70CD	70	150	1520	10.0	16.0	20.0		
PHL 80AD	80	100	1330	10.0	15.0	--		
PHL 80BD	80	120	1615	8.0	15.0	--		
PHL 80CD	80	150	1995	6.0	9.0	15.0		
PHL 90AD	90	100	1710	7.0	10.0	--		
PHL 90BD	90	120	1995	6.0	10.0	--		

Pump Model	Piston Φ (mm)	Stroke Speed (SPM)	Flow (LPH)	Pressure (Kg/Cm2(g))		
				2 HP	3 HP	5 HP
PHL 90CD	90	150	2565	5.0	8.0	10.0
PHL 100AD	100	100	2090	5.0	7.0	--
PHL 100BD	100	120	2470	5.0	7.0	--
PHL 115AD	115	100	2765	--	5.0	--
PHL 115BD	115	120	3325	--	5.0	--
PHL 115CD	115	150	3900	--	--	5.0
PHL 115RD	115	120	3500	--	--	5.0

Performances PHL Pump (Simplex - Plastic Liquid End)

Pump Model	Piston Φ (mm)	Stroke Speed (SPM)	Flow (LPH)	Pressure (Kg/Cm2(g))			End Connection	Diaphragm Size
				2 HP	3 HP	5 HP		
PHL 70A	70	100	1000	10	--	--	1-1/2"BSP(M)	266
PHL 70B	70	120	1300	10	--	--		
PHL 70C	70	150	1600	10	--	--		
PHL 80A	80	100	1400	10	--	--		
PHL 80B	80	120	1700	8	10	--		
PHL 80C	80	150	2100	6	10	--		
PHL 90A	90	100	1800	7	10	--		
PHL 90B	90	120	2100	6	10	--		
PHL 90C	90	150	2700	5	8	10		
PHL 100A	100	100	2200	5	7	--		
PHL 100B	100	120	2600	5	7	--		
PHL 115A	115	100	2900	--	5	--		
PHL 115B	115	120	3500	--	5	--		

Performances PHL Pump (Simplex - Plastic Liquid End) With DRDS

Pump Model	Piston Φ (mm)	Stroke Speed (SPM)	Flow (LPH)	Pressure (Kg/Cm2(g))			End Connection	Diaphragm Size
				2 HP	3 HP	5 HP		
PHL 70AD	70	100	950	10	--	--	1-1/2"BSP(M)	266
PHL 70BD	70	120	1235	10	--	--		
PHL 70CD	70	150	1520	10	--	--		
PHL 80AD	80	100	1330	10	--	--		
PHL 80BD	80	120	1615	8	10	--		
PHL 80CD	80	150	1995	6	10	--		
PHL 90AD	90	100	1710	7	10	--		
PHL 90BD	90	120	1995	6	10	--		
PHL 90CD	90	150	2565	5	8	10		
PHL 100AD	100	100	2090	5	7	--		
PHL 100BD	100	120	2470	5	7	--		
PHL 115AD	115	100	2765	--	5	--		
PHL 115BD	115	120	3325	--	5	--		
PHL 115CD	115	150	3900	--	--	5		
PHL 115RD	115	120	3500	--	--	5		

Performances PHL Pump (Duplex - Metallic Liquid End)

Pump Model	Piston Φ (mm)	Stroke Speed (SPM)	Flow (LPH)	Pressure (Kg/Cm2(g))			End Connection	Diaphragm Size
				3 HP	5 HP	7.5 HP		
PHL D 63A	63	100	1670	20.0	25.0	--	1" BSP(M)	166
PHL D 63B	63	120	2100	16.0	25.0	--		
PHL D 63C	63	150	2600	12.0	20.0	25.0		
PHL D 70A	70	100	2000	16.0	20.0	--	1-1/2" BSP(M)	266
PHL D 70B	70	120	2600	13.0	20.0	--		
PHL D 70C	70	150	3200	10.0	16.0	20.0		
PHL D 80A	80	100	2800	10.0	15.0	--		
PHL D 80B	80	120	3400	8.0	15.0	--		
PHL D 80C	80	150	4200	6.0	9.0	15.0		
PHL D 90A	90	100	3600	7.0	10.0	--		
PHL D 90B	90	120	4200	6.0	10.0	--		
PHL D 90C	90	150	5400	5.0	8.0	10.0		
PHL D 100A	100	100	4400	5.0	7.0	--		
PHL D 100B	100	120	5200	5.0	7.0	--		
PHL D 115A	115	100	5800	--	5.0	--		
PHL D 115B	115	120	7000	--	5.0	--		

Performances PHL Pump (Duplex - Metallic Liquid End) With DRDS

Pump Model	Piston Φ (mm)	Stroke Speed (SPM)	Flow (LPH)	Pressure (Kg/Cm2(g))			End Connection	Diaphragm Size
				3 HP	5 HP	7.5 HP		
PHL D 40AD	40	100	665	50.0	65.0	--	1" BSP(M)	166
PHL D 40BD	40	120	760	40.0	65.0	--		
PHL D 40CD	40	150	950	32.0	50.0	65.0		
PHL D 50AD	50	100	995	32.0	40.0	--		
PHL D 50BD	50	120	1216	25.0	40.0	--		
PHL D 50CD	50	150	1520	20.0	32.0	40.0		
PHL D 63AD	63	100	1585	20.0	25.0	--		
PHL D 63BD	63	120	1995	16.0	25.0	--		
PHL D 63CD	63	150	2470	12.0	20.0	25.0		
PHL D 70AD	70	100	1900	16.0	20.0	--	1-1/2" BSP(M)	266
PHL D 70BD	70	120	2470	13.0	20.0	--		
PHL D 70CD	70	150	3040	10.0	16.0	20.0		
PHL D 80AD	80	100	2660	10.0	15.0	--		
PHL D 80BD	80	120	3230	8.0	15.0	--		
PHL D 80CD	80	150	3990	6.0	9.0	15.0		
PHL D 90AD	90	100	3420	7.0	10.0	--		
PHL D 90BD	90	120	3990	6.0	10.0	--		
PHL D 90CD	90	150	5130	5.0	8.0	10.0		
PHL D 100AD	100	100	4180	5.0	7.0	--		
PHL D 100BD	100	120	4940	5.0	7.0	--		
PHL D 115AD	115	100	5510	--	5.0	--		
PHL D 115BD	115	120	6650	--	5.0	--		

Performances PHL Pump (Duplex - Plastic Liquid End)

Pump Model	Piston Φ (mm)	Stroke Speed (SPM)	Flow (LPH)	Pressure (Kg/Cm2(g))			End Connection	Diaphragm Size
				3 HP	5 HP	7.5 HP		
PHL D 70A	70	100	2000	10	--	--	1-1/2"BSP(M)	266
PHL D 70B	70	120	2600	10	--	--		
PHL D 70C	70	150	3200	10	--	--		
PHL D 80A	80	100	2800	10	--	--		
PHL D 80B	80	120	3400	8	10	--		
PHL D 80C	80	150	4200	6	10	--		
PHL D 90A	90	100	3600	7	10	--		
PHL D 90B	90	120	4200	6	10	--		
PHL D 90C	90	150	5400	5	8	10		
PHL D 100A	100	100	4400	5	7	--		
PHL D 100B	100	120	5200	5	7	--		
PHL D 115A	115	100	5800	--	5	--		
PHL D 115B	115	120	7000	--	5	--		

Performances PHL Pump (Duplex - Plastic Liquid End) With DRDS

Pump Model	Piston Φ (mm)	Stroke Speed (SPM)	Flow (LPH)	Pressure (Kg/Cm2(g))			End Connection	Diaphragm Size
				3 HP	5 HP	7.5 HP		
PHL D 70AD	70	100	1900	10	--	--	1-1/2"BSP(M)	266
PHL D 70BD	70	120	2470	10	--	--		
PHL D 70CD	70	150	3040	10	--	--		
PHL D 80AD	80	100	2660	10	--	--		
PHL D 80BD	80	120	3230	8	10	--		
PHL D 80CD	80	150	3900	6	10	--		
PHL D 90AD	90	100	3420	7	10	--		
PHL D 90BD	90	120	3990	6	10	--		
PHL D 90CD	90	150	5130	5	8	10		
PHL D 100AD	100	100	4180	5	7	--		
PHL D 100BD	100	120	4940	5	7	--		
PHL D 115AD	115	100	5510	--	5	--		
PHL D 115BD	115	120	6650	--	5	--		

Dimensions

PHL Simplex Metallic:

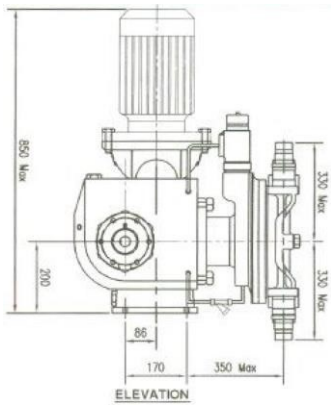

PHL Simplex Plastic:

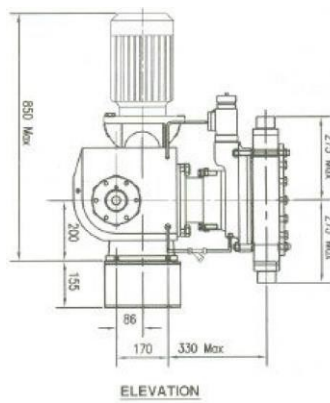

Side View (Metallic/Plastic Liquid End):

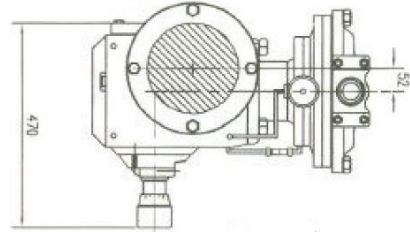

PHL Duplex Metallic:

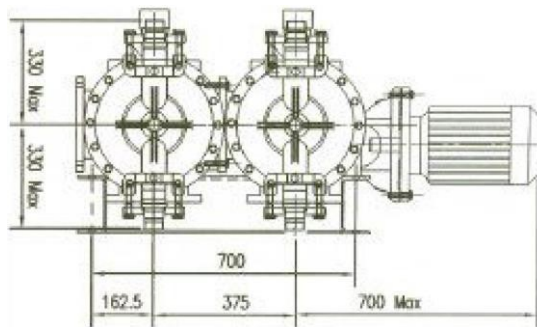

PHL Duplex Plastic:

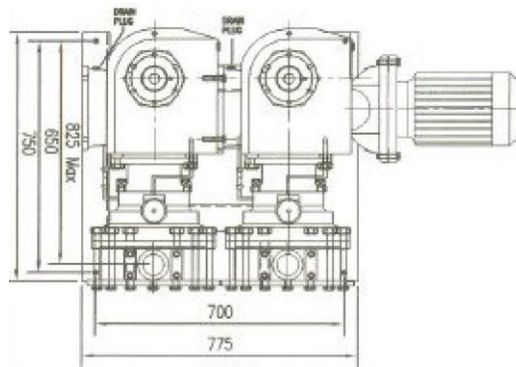
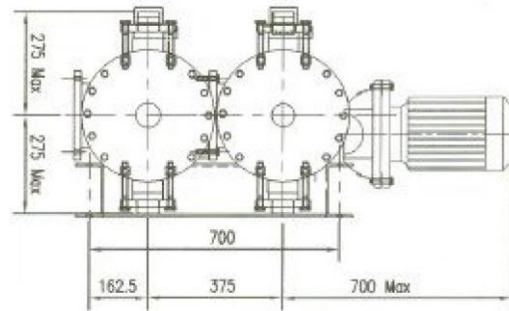

Side View (Metallic/Plastic Liquid End):

*Any changes in this catalogue applicable without prior Information

Plot No: 45/1, 8th Avenue, Domestic Tariff Area,
Mahindra World City, Chengalpet District,
Chengalpet – 603004, Tamilnadu, India.
Tel Ph. No: +91-44-71113111
mr-sales@miltonroy.com | www.miltonroyindia.com