

# Dosing pump series - GMZ

- Maximum Flow rate: 200 l/h
- Maximum Pressure: 15 kg/cm<sup>2</sup>g
- Mechanically actuated diaphragm
- Slider Crank drive mechanism

## Technical characteristics

### Standard:

- Flow rate up to 200 l/h
- Pressure up to 15 kg/cm<sup>2</sup>g
- Long life PTFE Hypalon diaphragm
- Mechanically actuated diaphragm
- Stroke adjustment by slider-polar crank minimizing pulsation and enhanced mechanical stability
- Simplex version
- Maximum temperature of pumped liquid: 50 °C
- Adjustment of flow rate while running from 0 to 100%
- Accuracy: ± 2% of rated flow from 10% to 100% stroke
- Suction lift: up to 1.5 m water
- Turn down ratio 10:1
- Lubrication by oil bath
- Viscosity handled: up to 100 cps
- Stroke adjustment lock

## Characteristics of motors

### Standard Motor Data:

- Power Supply: 415V / 380V – 50 Hz – 3 phases, IE2.  
*(Voltage selection based on regional standards. Please specify at the time of order.)*
- Degree of protection: IP 55
- Insulation: class F
- Motor Speed: 4 Pole
- Enclosure: TEFC

## Accessories\*\*

To meet your installation needs a large range of accessories are available on request (Pulsation dampeners, safety and backpressure valves), consult us.



## Liquid end construction\*

Component	Materials	
Liquid endbody	PP	CF8M / SS316
Valve body	PVC	SS-316
Ring Seal	PTFE	PTFE
Balls	CERAMIC	CERAMIC
Connections	PVC	SS-316
Diaphragm	TEFLON FACED HYPALON	TEFLON FACED HYPALON
PRV	PVC	SS-316
Suction-Strainer	PP Y-Type	CF8M Y-Type
Antisiphon valve	PVC	SS-316

\*Special MOC available on request for PVDF, SS316L etc.

\*\* Option for pump with base available on special request .

## Performances

Pump mode	Flow max. (l/h)		Pressure max. (KG/CM2)	Stroke speed (SPM)	Motor speed (rpm)	Motor power (kW)	End Connections (Suction & Discharge)	
	Min (l/h)	Max (l/h)					Metallic	Plastic
GMZ-09	0.5	5	15	48	1320	0.18	½" BSP(F) x ½" NPT(M)	
GMZ-10	1.0	10	15	96	1320	0.18	½" BSP(F) x ½" NPT(M)	
GMZ-11	1.7	17	10	144	1320	0.18	½" BSP(F) x ½" NPT(M)	
GMZ-12	3	30	10	144	1320	0.18	½" BSP(F) x ½" NPT(M)	
GMZ-13	5	50	5	144	1320	0.18	½" BSP(F) x ½" NPT(M)	
GMZ-14	10	100	3	144	1320	0.18	½" BSP(F) x ½" NPT(M)	
GMZ-15	20	200	3	196	1400	0.37	½" BSP(F) x ½" NPT(M)	

## Dimensions and Connections

### GMZ

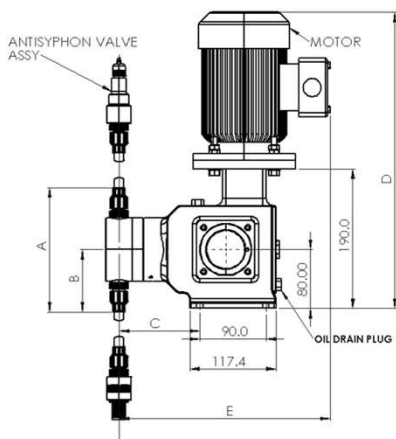

GMZ SIDE VIEW

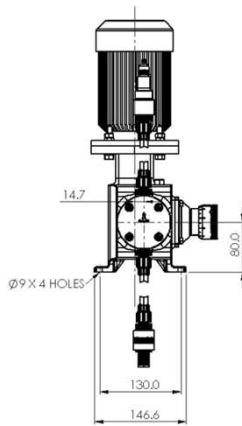

GMZ FRONT VIEW

MODELS	Dimensions (mm)				
	A ± 5.0	B ± 5.0	C ± 5.0	D ± 5.0 (MAX)	E ± 5.0
GMZ-09	170	85.2	112.2	404	288
GMZ-10			112.6		290.3
GMZ-11			109		286.7
GMZ-12	178.7	88.7	125.4	430	303.1
GMZ-13	237.8	118	125.4		310
GMZ-14					
GMZ-15					

### Weight GMZ

Liquid End	Pump Weight (kg) Approx.
Metallic	14
Plastic	10

## MILTONROY INDIA PVT. LTD.

Plot No: 45/1, 8th Avenue, Domestic Tariff Area,  
Mahindra World City, Chengalpattu District,  
Chengalpattu – 603004, Tamil Nadu, India.

+91-44-71113111

marketingmei@irco.com



Disclaimer: Catalogue contents may change without prior notice.