

CHEMFLO 5 CC

2" x 1-1/2" End Suction Centrifugal Pump

Made with high quality investment cast 316 stainless steel components, the ChemFlo® series of pumps are designed to be applied in a wide range of pumping applications where stainless steel is required.

The ChemFlo® 5 pumps utilize an enclosed impeller designed for achieving higher heads and efficiencies than a standard semi-open impeller. Multiple impeller trims allow the ChemFlo® 5 to meet most duty points up to 300 GPM (68.1 m³/h) and total head up to 157 feet (48 m). Several mechanical seal options are available in addition to the standard type 2100 carbon / ceramic / Viton mechanical seal.

ChemFlo® 5 pumps are offered in two configurations, pump (with motor) and PumPAK® (without motor) versions. Motors available are 145TC, 184TC, and 215TC. If ordering a PumPAK please note that the electric motor must have a base.

SPECIFICATIONS:

Suction and Discharge	2" x 1-1/2" ANSI 150# flange
Materials of Construction	316 stainless steel
Flow	Up to 300 GPM (68.1 m ³ /h)
Head Feet	Up to 157' (48 m)
Impeller	6.18" (156.97 mm) enclosed, cast 316 SS
Motor	Up to 10 HP (7 kW)
Drive Options	Close coupled 145TC Close coupled 184TC Close coupled 215TC Pedestal PumPAK® (without motor)
Seal	Special seal material combinations available (consult factory), Standard carbon / ceramic / Viton
Options	Tap for recirculation or seal flush, Hydraulic motor driven pedestals and shaft driven pedestals
Drive Sleeve	316 Stainless Steel

Application:

- Agricultural
- Commercial
- Industrial
- Marine
- OEM



12500 South Pulaski Road
Alsip, IL 60803, USA
Phone (800) 563-8006



An Ingersoll Rand Business

CHEMFLO 5 CC

PERFORMANCE CURVES

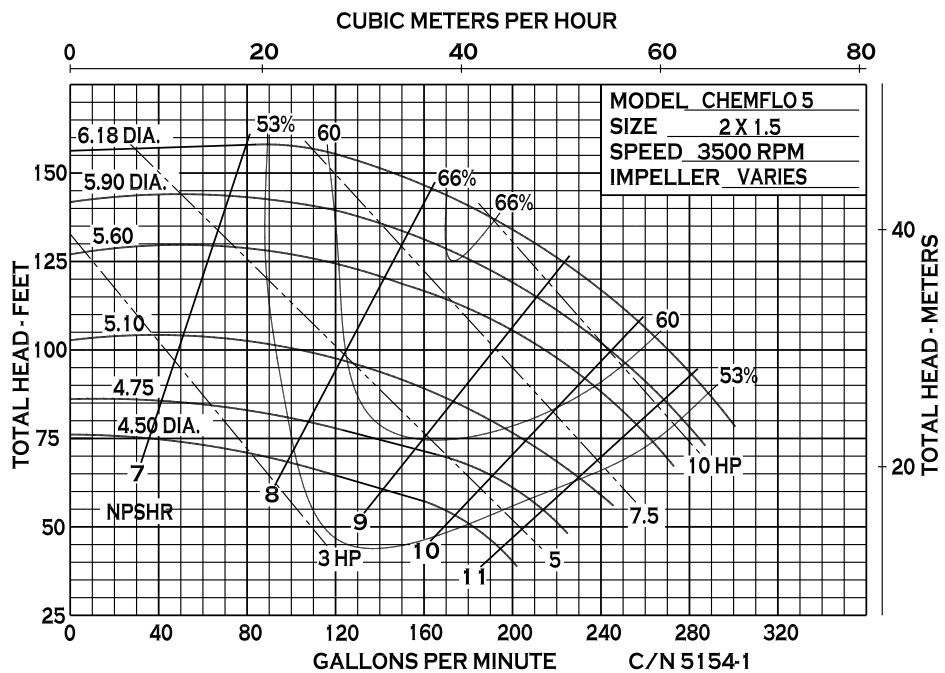
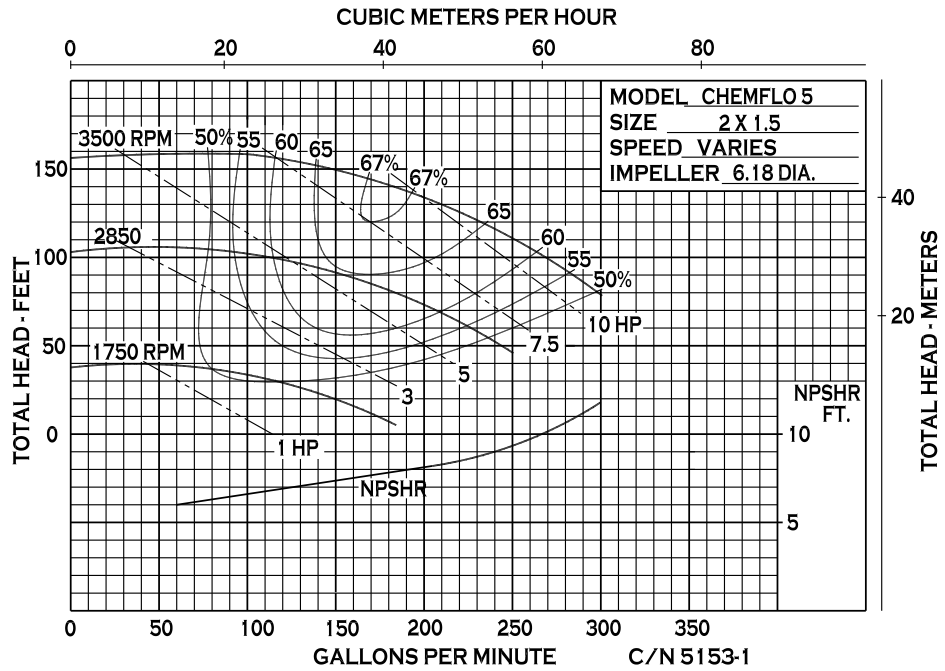

12500 South Pulaski Road
 Alsip, IL 60803, USA
 Phone (800) 563-8006



An Ingersoll Rand Business

CHEMFLO 5 CC

PERFORMANCE CURVES

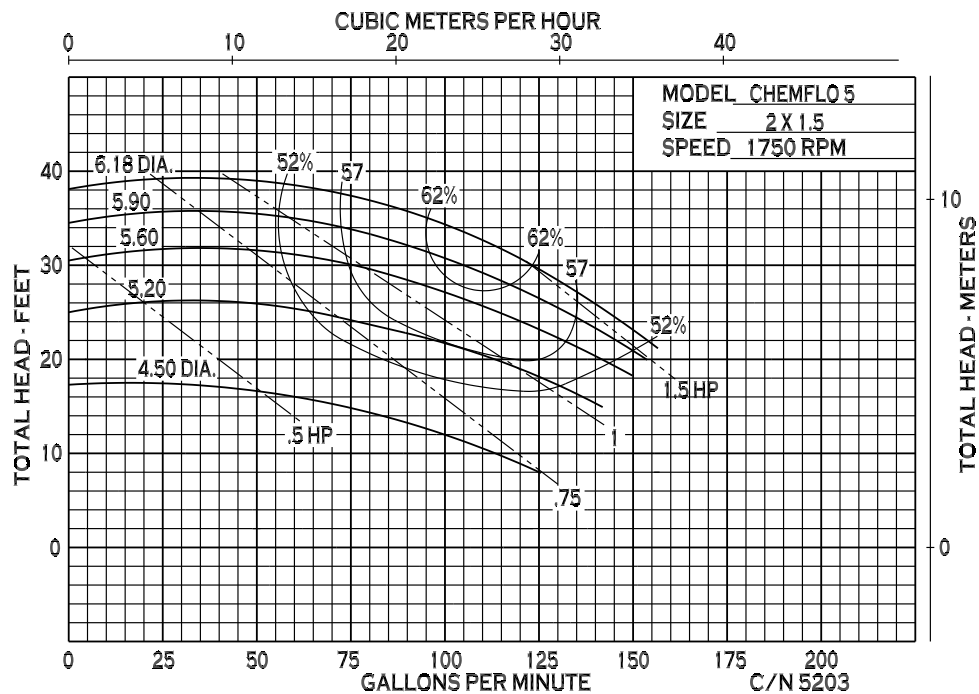
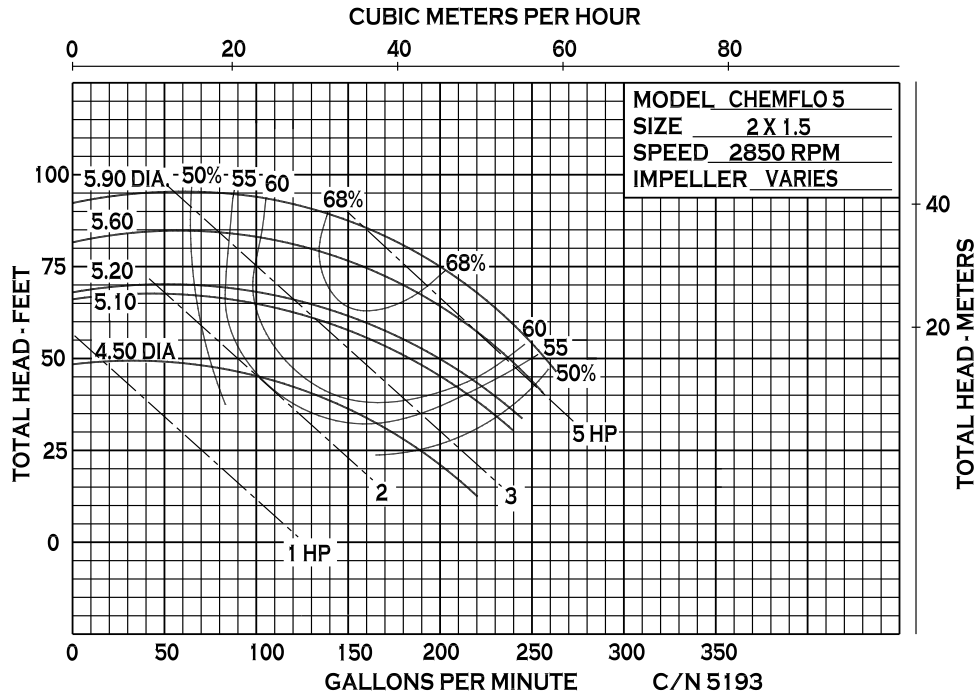

12500 South Pulaski Road
 Alsip, IL 60803, USA
 Phone (800) 563-8006



An Ingersoll Rand Business

CHEMFLO 5 CC

DIMENSIONS

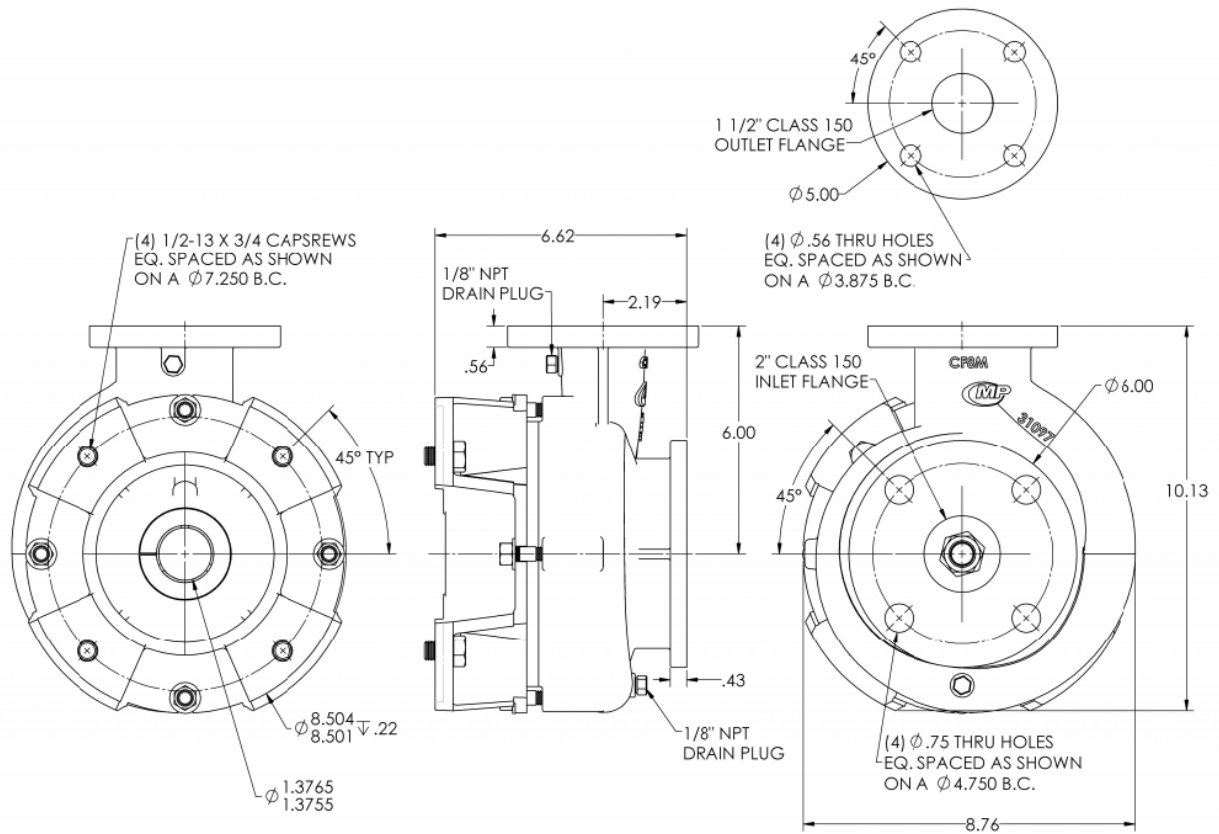

CF5 PUMPAK FOR 215TC



12500 South Pulaski Road
Alsip, IL 60803, USA
Phone (800) 563-8006



An Ingersoll Rand Business

CHEMFLO 5 CC

DIMENSIONS

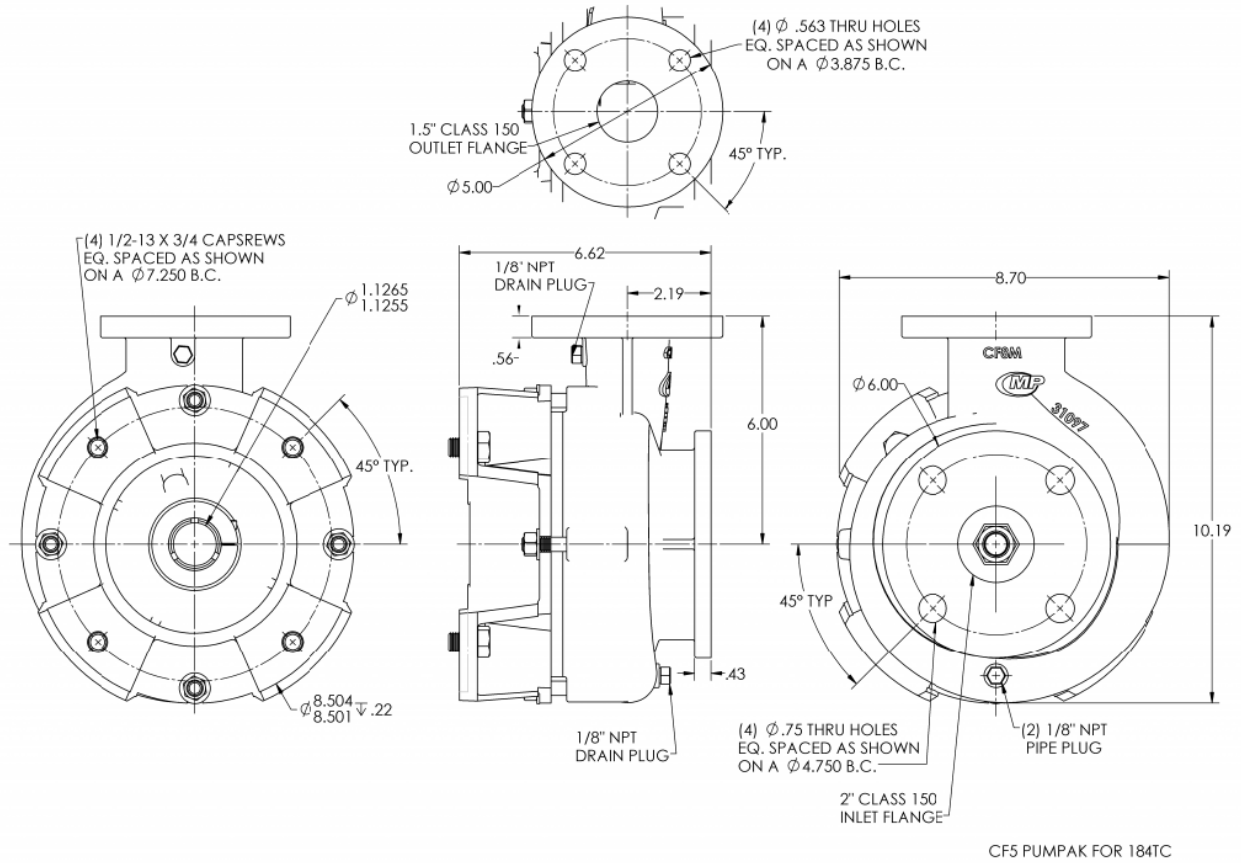

12500 South Pulaski Road
Alsip, IL 60803, USA
Phone (800) 563-8006



An Ingersoll Rand Business

CHEMFLO 5 CC

DIMENSIONS

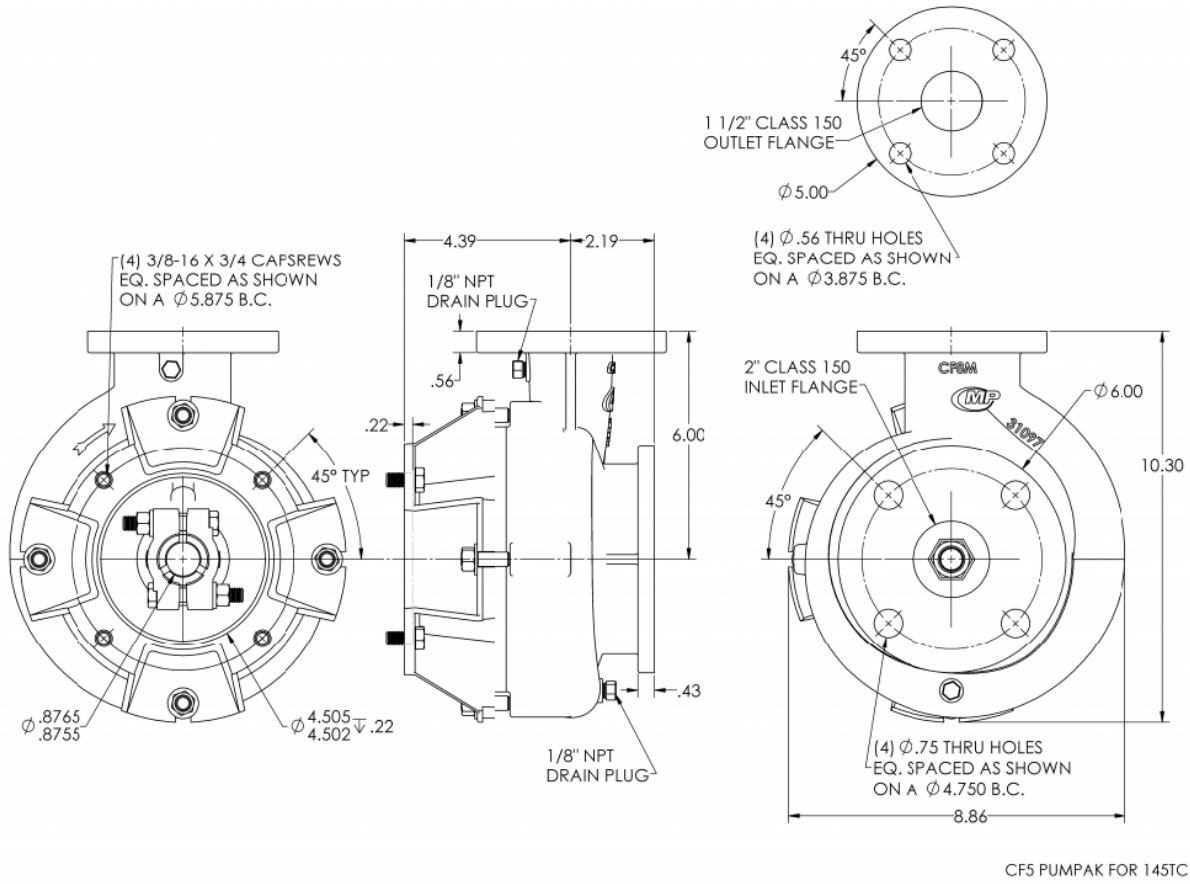

* For complete parts lists and troubleshooting guidance, please refer to the MP Pumps Installation Operation & Maintenance (IOM) Manual.



12500 South Pulaski Road
Alsip, IL 60803, USA
Phone (800) 563-8006