

# CHEMFLO 9 Pedestal

## 2" x 1" End Suction Centrifugal Pump

Made with high quality investment cast 316 stainless steel components, the ChemFlo® series of pumps are designed to be applied in a wide range of pumping applications where stainless steel is required.

The ChemFlo® 9 pumps utilize an enclosed impeller designed for achieving higher heads and efficiencies than a standard semi-open impeller. Multiple impeller trims allow the ChemFlo® 9 to meet most duty points up to 270 GPM (61 m<sup>3</sup>/h) and total head up to 460 feet (140 m). Several mechanical seal options are available in addition to the standard type 2100 carbon / ceramic / Viton mechanical seal.

All wetted components are 316 investment cast stainless steel providing superior corrosion resistance when pumping chemical compounds. The Chemflo® 9 pedestal uses a pump end (PumPAK®) design that is interchangeable with 184TC, 215TC, 256TC, 284TSC and 286TSC electric motors. If ordering a PumPAK® with a 145TC please note that the electric motor must have a base.

### SPECIFICATIONS:

<b>Suction / Discharge</b>	2" x 1" ANSI 150# flange
<b>Materials of Construction</b>	316 Stainless Steel
<b>Flow</b>	Up to 270 GPM (61 m <sup>3</sup> /h)
<b>Head Feet</b>	Up to 460' (140 m)
<b>Impeller</b>	9.95" (252.7 mm) enclosed, cast 316 SS
<b>Seal</b>	Special seal material combinations available (consult factory), Standard carbon / ceramic / Viton
<b>Drive Options</b>	Close coupled 184TC Close coupled 215TC Close coupled 256TC Close coupled 284TSC Close coupled 286TSC Pedestal PumPak® (without motor)
<b>Drive Sleeve</b>	316 stainless steel

### Application:

- Agricultural
- Commercial
- Industrial
- Marine
- OEM



An Ingersoll Rand Business

# CHEMFLO 9 Pedestal

## PERFORMANCE CURVES

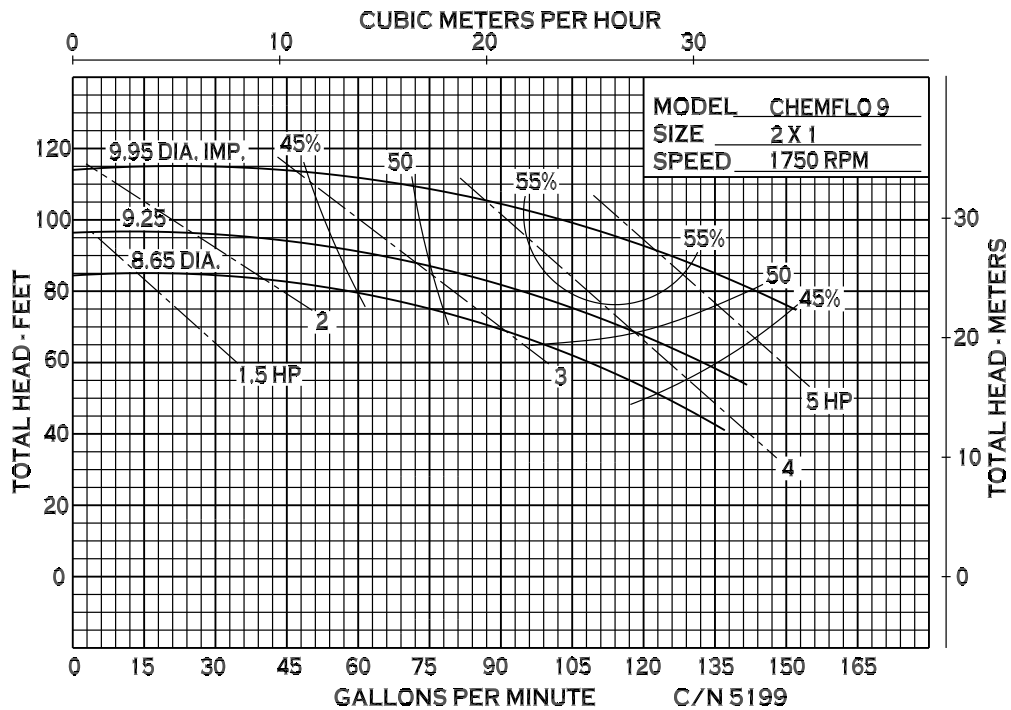
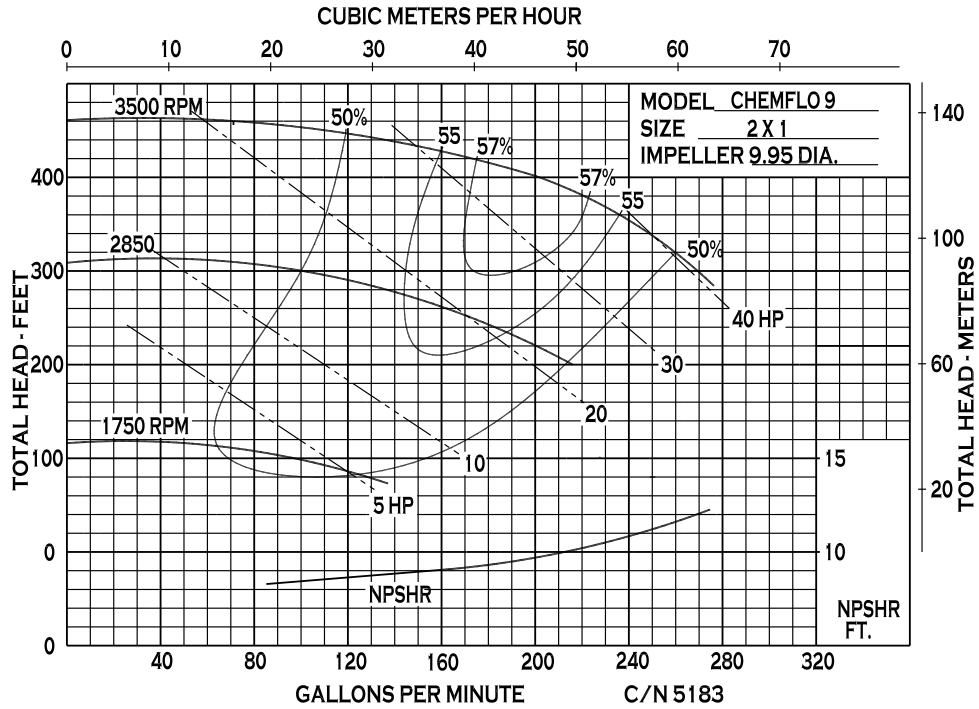

12500 South Pulaski Road  
 Alsip, IL 60803, USA  
 Phone (800) 563-8006



An Ingersoll Rand Business

# CHEMFLO 9 Pedestal

## PERFORMANCE CURVES

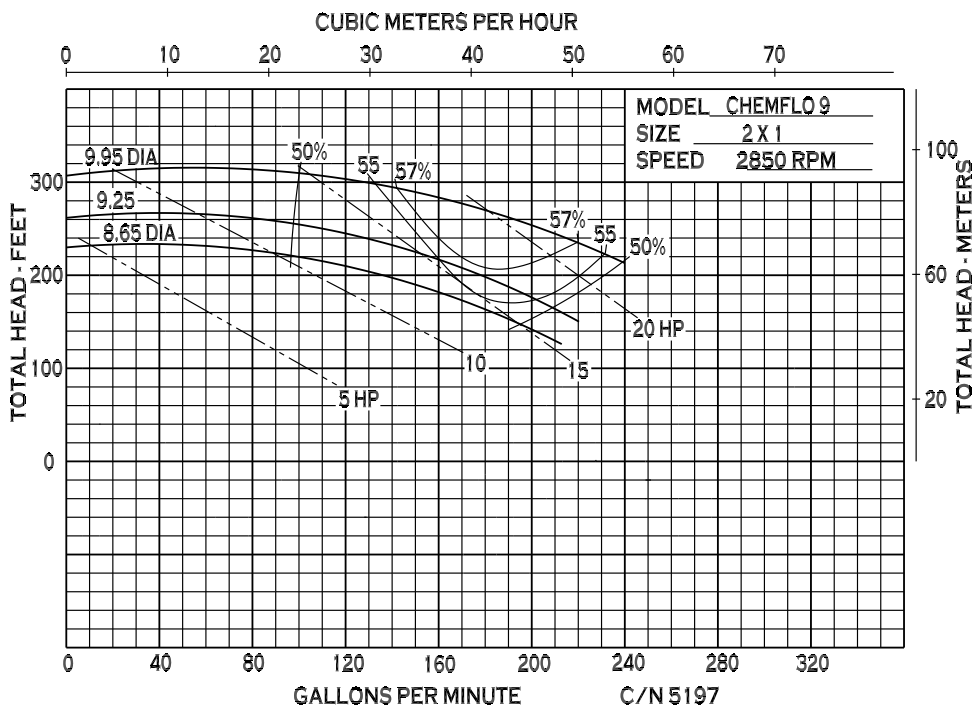
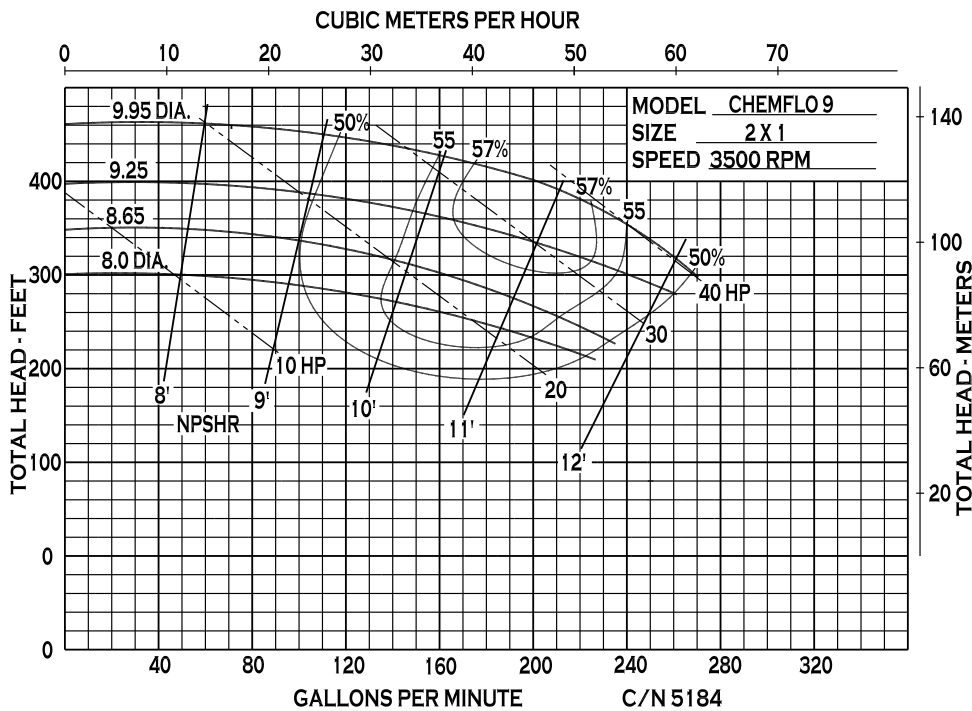

12500 South Pulaski Road  
 Alsip, IL 60803, USA  
 Phone (800) 563-8006



An Ingersoll Rand Business

# CHEMFLO 9 Pedestal

## DIMENSIONS

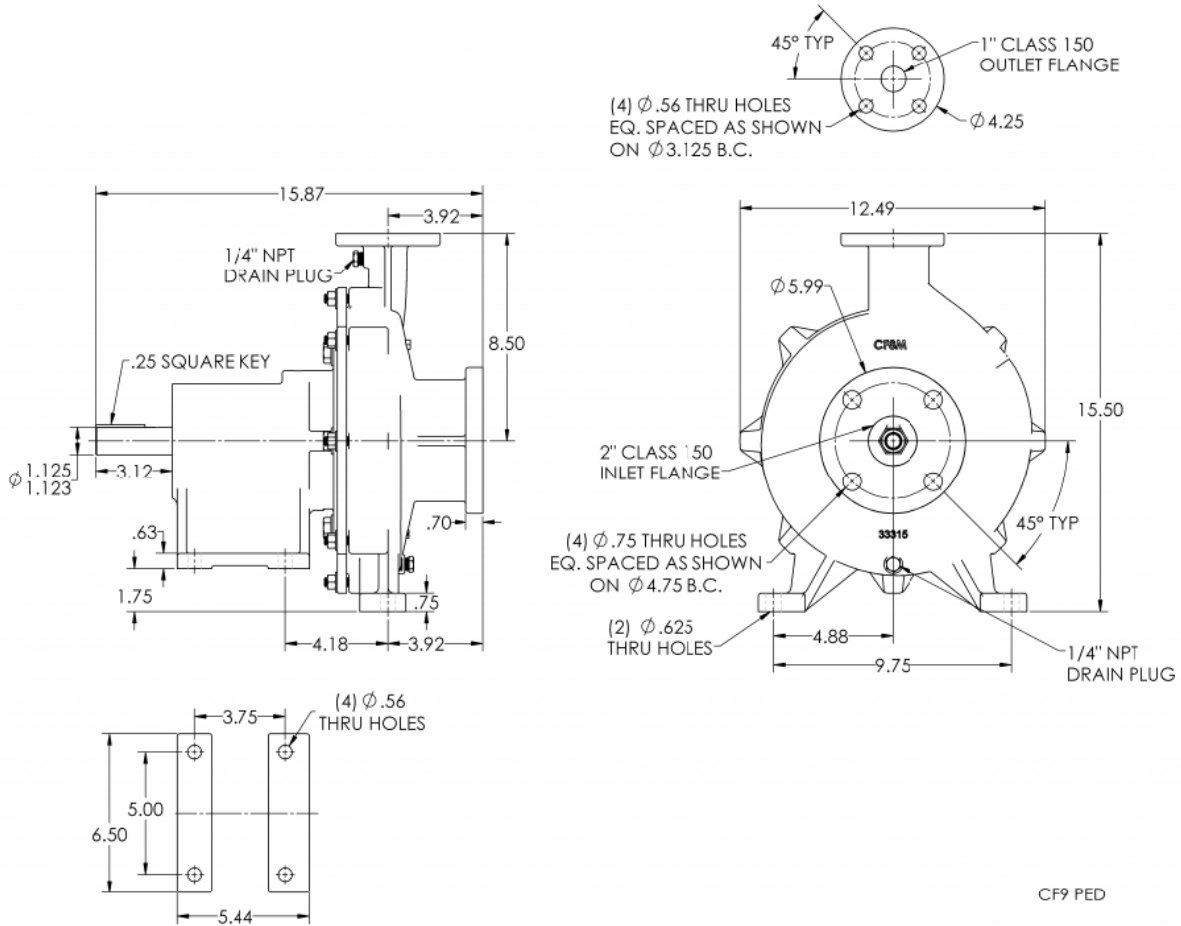

\* For complete parts lists and troubleshooting guidance, please refer to the MP Pumps Installation Operation & Maintenance (IOM) Manual.



12500 South Pulaski Road  
Alsip, IL 60803, USA  
Phone (800) 563-8006