



CHEMFLO 5 Pedestal

2" x 1-1/2" End Suction Centrifugal Pump

Made with high quality investment cast 316 stainless steel components, the ChemFlo® series of pumps are designed to be applied in a wide range of pumping applications where stainless steel is required.

The ChemFlo® 5 pumps utilize an enclosed impeller designed for achieving higher heads and efficiencies than a standard semi-open impeller. Multiple impeller trims allow the ChemFlo® 5 to meet most duty points up to 300 GPM (68.1 m³/h) and total head up to 157 feet (48 m). Several mechanical seal options are available in addition to the standard type 2100 carbon / ceramic / Viton mechanical seal.

All wetted components are 316 investment cast stainless steel providing superior corrosion resistance when pumping chemical compounds. The Chemflo® 5 pedestal uses a pump end (PumPAK®) design that is interchangeable with 145TC, 184TC, or 215TC electric motors. If ordering a PumPAK® with a 145TC please note that the electric motor must have a base.

SPECIFICATIONS:

Suction / Discharge	2" x 1-1/2" ANSI 150# flange
Materials of Construction	316 Stainless Steel
Flow	300 GPM (68 m ³ /h)
Head Feet	Up to 157' (48 m)
Impeller	6.18" (156.97 mm) enclosed, cast 316 SS
Seal	Special seal material combinations available (consult factory), Standard carbon / ceramic / Viton
Drive Options	Close Coupled 145TC Close coupled 184TC Close coupled 215TC Pedestal PumPak® (without motor)
Drive Sleeve	316 stainless steel

Application:

- Agricultural
- Commercial
- Industrial
- Marine
- OEM



12500 South Pulaski Road
Alsip, IL 60803, USA
Phone (800) 563-8006



An Ingersoll Rand Business

CHEMFLO 5 Pedestal

PERFORMANCE CURVES

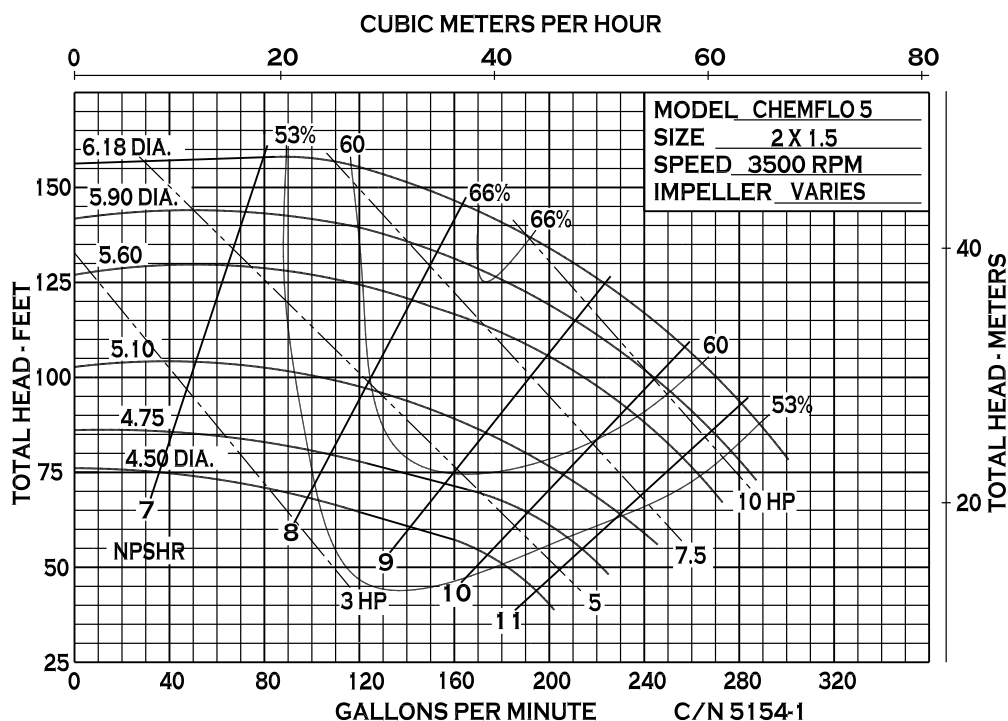
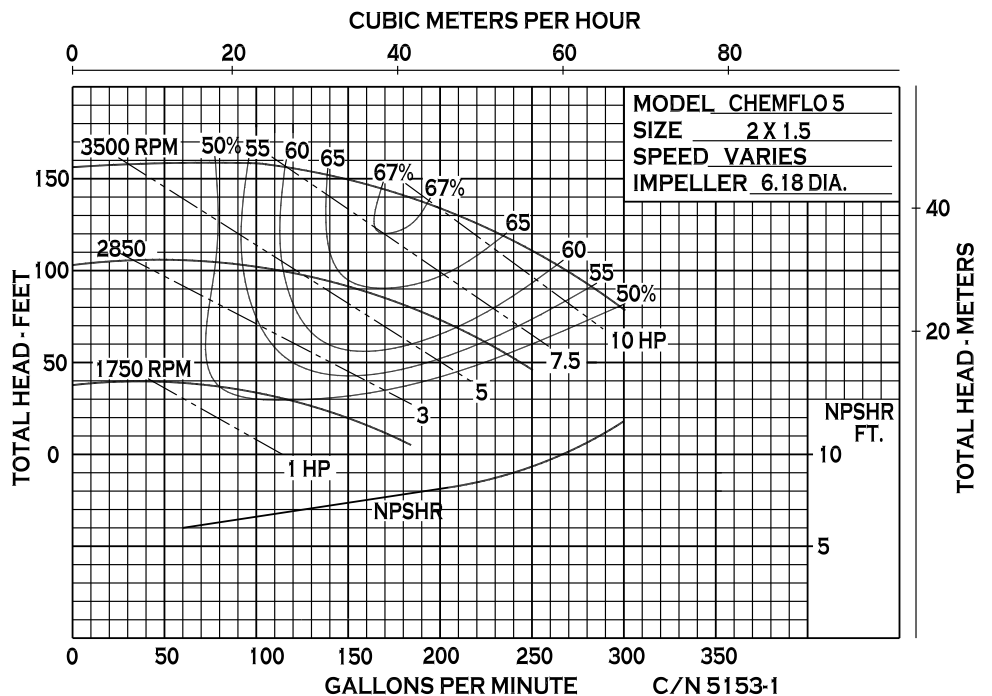

12500 South Pulaski Road
 Alsip, IL 60803, USA
 Phone (800) 563-8006



An Ingersoll Rand Business

CHEMFLO 5 Pedestal

PERFORMANCE CURVES

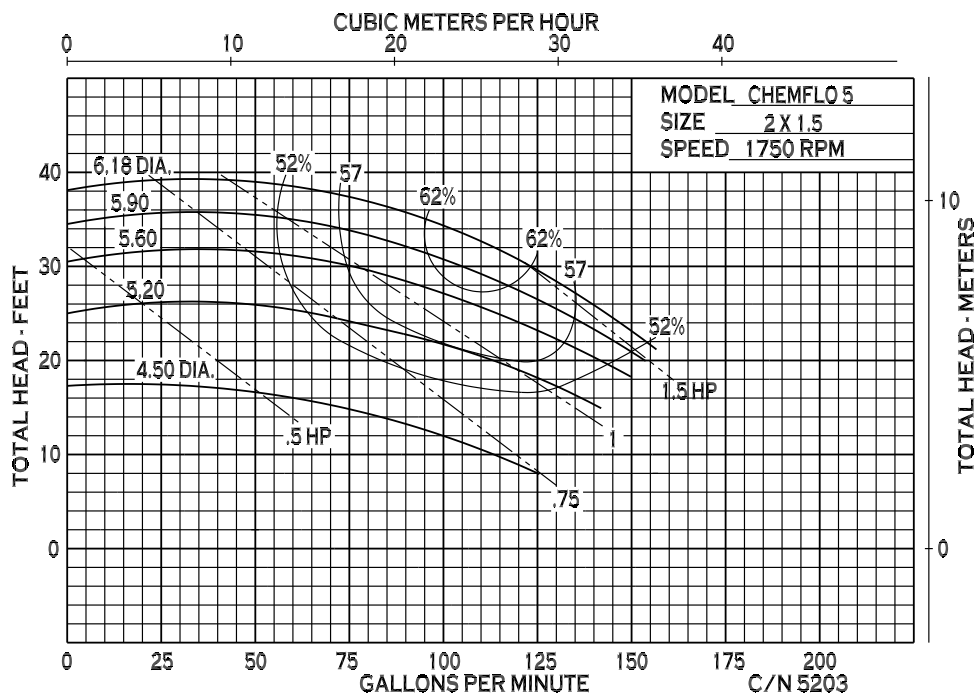
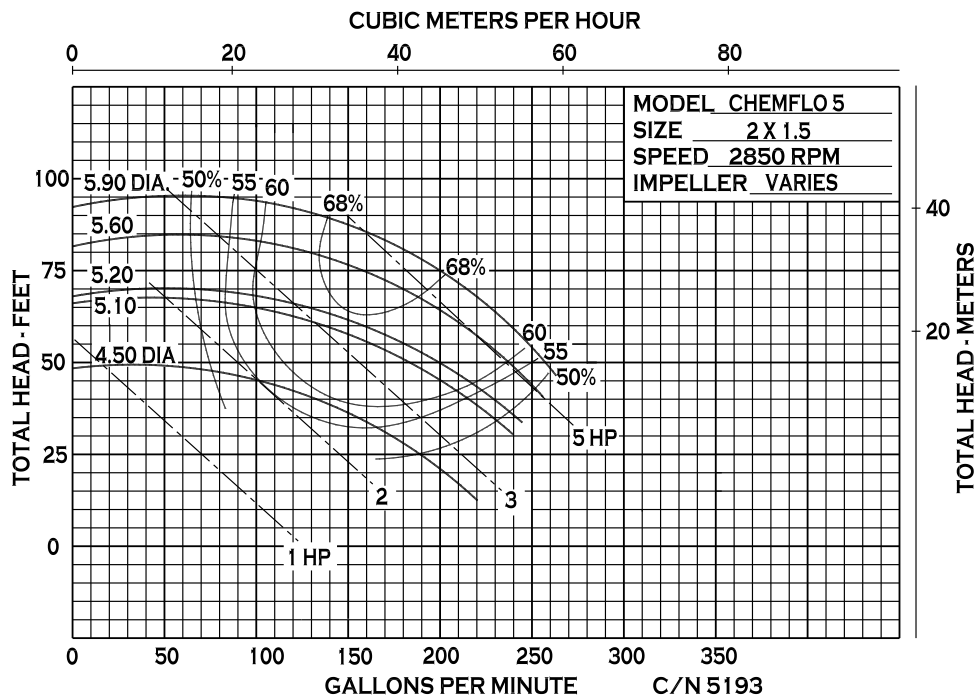

12500 South Pulaski Road
Alsip, IL 60803, USA
Phone (800) 563-8006



An Ingersoll Rand Business

CHEMFLO 5 Pedestal

DIMENSIONS

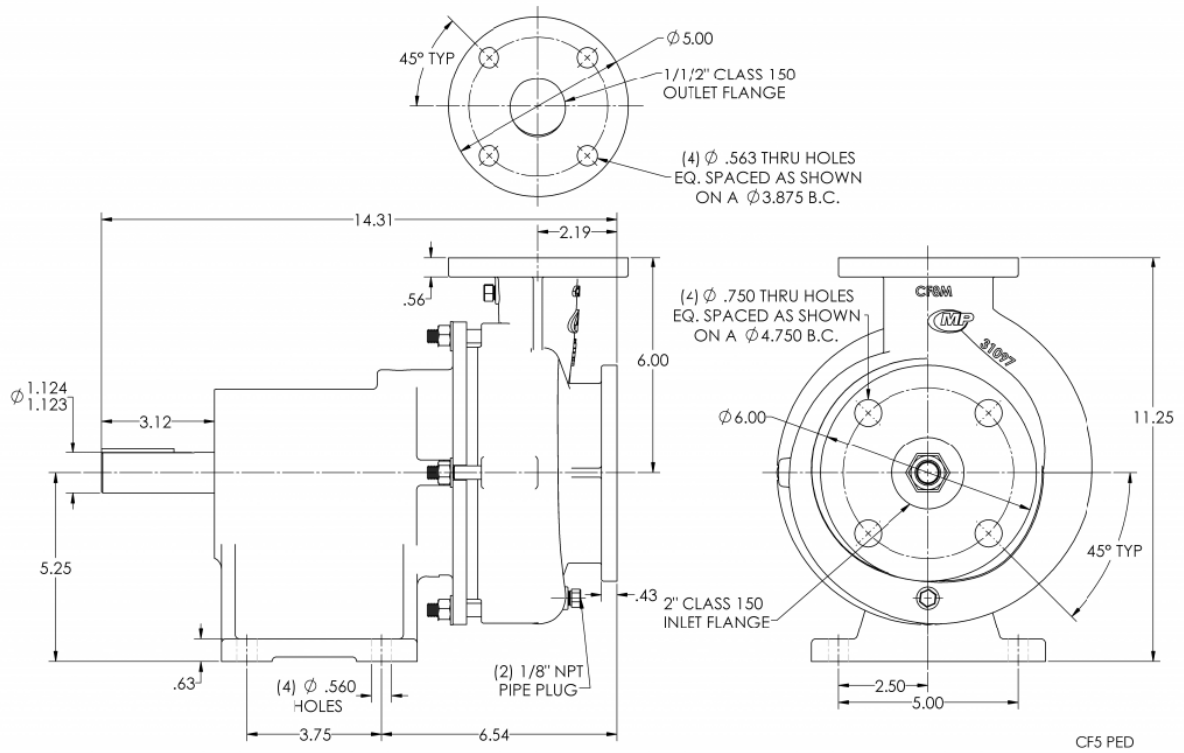

* For complete parts lists and troubleshooting guidance, please refer to the MP Pumps Installation Operation & Maintenance (IOM) Manual.



12500 South Pulaski Road
Alsip, IL 60803, USA
Phone (800) 563-8006