



VSC SERIES

Dry Screw Vacuum Pumps & Systems



VSC SERIES

Dry Screw Vacuum Pumps & Systems

The NASH VSC Dry Screw Series represents the next generation of dry screw vacuum technology, built for the demanding requirements of Process Industries in North America. Designed, machined, and supported in the United States, the VSC combines rugged reliability, optimized thermal control, and simplified maintenance to deliver superior performance in the harshest environments.



Need safe and reliable vacuum solutions?

You need NASH.

A Tradition of Engineered Excellence

Since 1905, our global customer base has enjoyed the benefits of our industry-leading experience and engineering expertise. Nash designs, delivers, and services world-class vacuum solutions that tackle the rigorous demands of a vast range of industrial processes. Our reliable and well-engineered solutions guarantee the quality and performance even the most harsh industries demand.

Nash offers a complete range of vacuum solutions such as liquid ring vacuum pumps, compressors and systems, steam ejectors, hybrid vacuum systems, as well as dry vacuum pumps & systems.

The **NASH VSC Series dry screw vacuum pumps** continue this tradition of delivering high-quality, best-in-class vacuum solutions for chemical and pharmaceutical industries.

- **Decades of experience**
 - Over 120 years of applications expertise
 - ETO System design by tenured engineers
- **The most reliable vacuum pumps in the industry**
 - Rugged designs, purpose built from experience
- **Expert engineers and advanced technical support**
 - Tailored solutions to meet your needs
 - Answers when you need them, even decades later

When reliability, serviceability, and performance matter most, trust NASH—the name synonymous with rugged vacuum solutions for over a century.



Built for Performance

The NASH VSC dry screw pump is a tireless workhorse. Its simple yet sophisticated design ensures continuous operation, even under challenging conditions, making it highly suitable for demanding chemical vacuum applications. This robust machine delivers reliable and efficient performance while offering flexibility for a wide range of processes.

The entire operation is dry, with no lubrication in the pumping chamber. This guarantees no contamination or pollution caused by the pump and eliminates corrosion because process media remain in the vapor phase. Combined with advanced rotor technology and optimized thermal control, the VSC vacuum pump provides superior efficiency and durability.

Applications Engineering Expertise & Knowledge

Nash has the technical expertise to provide comprehensive product and applications engineering support. Our approach to your needs is flexible and accommodating. We work directly with our customers to understand their process requirements, enabling our expert engineers to design and deliver the optimal solution.

Handle an Array of Chemicals

The NASH VSC Series is engineered to manage a wide range of chemicals commonly processed under vacuum in North America. From distillation and drying to solvent recovery and polymerization, the VSC dry screw vacuum pump delivers clean, oil-free vacuum for critical chemical operations.

- **Acids:** Hydrochloric, Sulfuric, Nitric, Phosphoric, Acetic, Formic
- **Alcohols:** Methanol, Ethanol, Isopropanol, Butanol
- **Amines:** MEA, DEA, TEA, Triethylamine
- **Aromatics (BTX):** Benzene, Toluene, Xylene
- **Halogenated Compounds:** Ethylene Dichloride, Methylene Chloride, Chloroform
- **Ketones:** Acetone, MEK, Cyclohexanone
- **Ethers:** Diethyl Ether, Tetrahydrofuran (THF)
- **Isocyanates:** MDI, TDI
- **Hydrocarbons:** Paraffins (Pentane, Hexane), Olefins
- **Polymers & Intermediates:** Polycarbonates, Polyglycols, Polyurethanes, PVC Monomers
- **Other:** Adhesives, Fatty acids, Glycerides, Sulphides, Phenol, Styrene, Caprolactam, Silicones

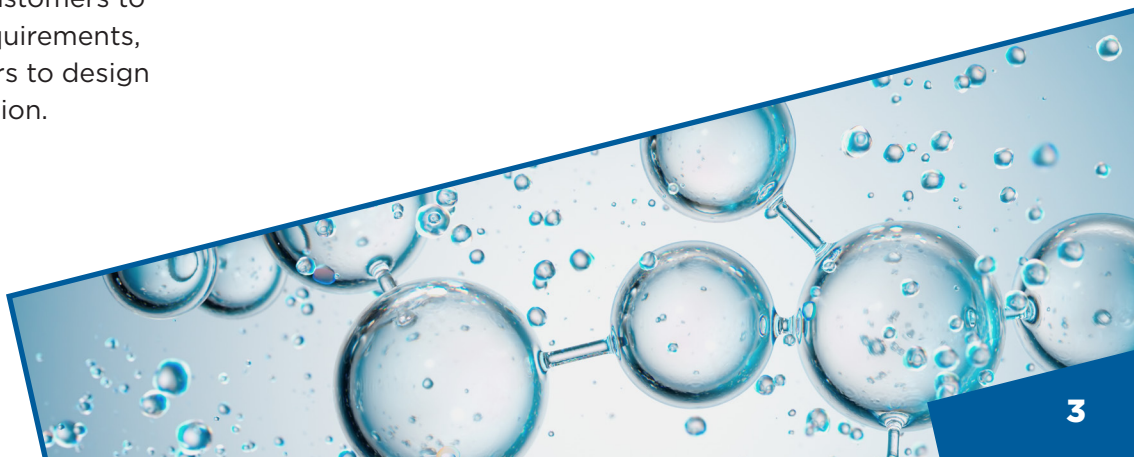

PRODUCT FEATURES

1. Continuously Variable Pitch Rotors

Unmatched thermal control, reliability, and efficiency.

2. Plated Internals

Two-Stage Nickel/chrome plating for corrosion and wear resistance.

3. Mechanical Seal with Gas Barrier

Improved reliability and reduced nitrogen consumption.

Purpose-Built for Reliable Process Operations

Dry screw vacuum pumps are often selected when traditional technologies fall short of modern demands. When a solution is needed to reduce environmental impact, lower energy consumption, minimize footprint, eliminate process contamination, or any combination of those, the NASH VSC Series delivers. Engineered and optimized by Nash for clean, reliable performance, the VSC is purpose-built for critical applications such as:

- Vacuum distillation (thin-film, molecular)
- Evaporation and concentration
- Drying processes (vacuum drying, freeze drying, lyophilization)
- Degassing of liquids and polymers
- Solvent recovery and vapor handling
- Vacuum-assisted chemical reactions
- Polymerization and catalyst processing
- Crystallization under vacuum
- Sterilization of equipment and components
- API (Active Pharmaceutical Ingredient) production
- Vacuum coating and thin-film deposition
- Freeze drying for pharmaceuticals and food
- Vacuum sterilization for medical devices

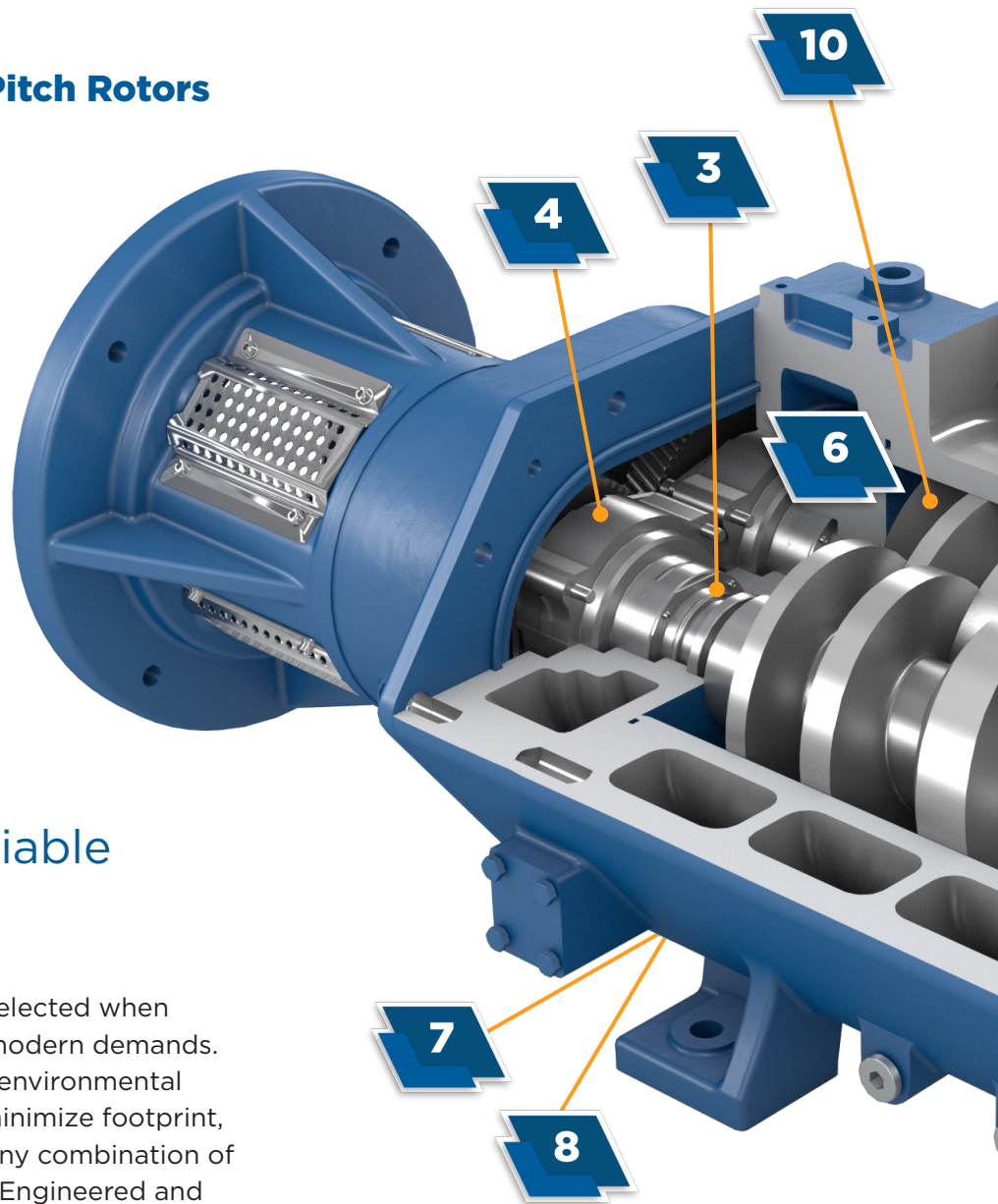

4. Oil-Lubricated Bearings

Easy service and extended life.

5. Cooling Jacket

Uniform thermal profile prevents hot spots.

6

6. Gas Ballast Port

Process flexibility for condensable loads.

7. Bottom Discharge

Efficient drainage and reduced contamination risk.

8. ANSI Flanges

Standardized inlet and exhaust connections for easy integration.

9. Piston Ring Seals

Improved protection for demanding process conditions.

10. No End Plate Compression

Reduced load on seals and no localized hot spots.

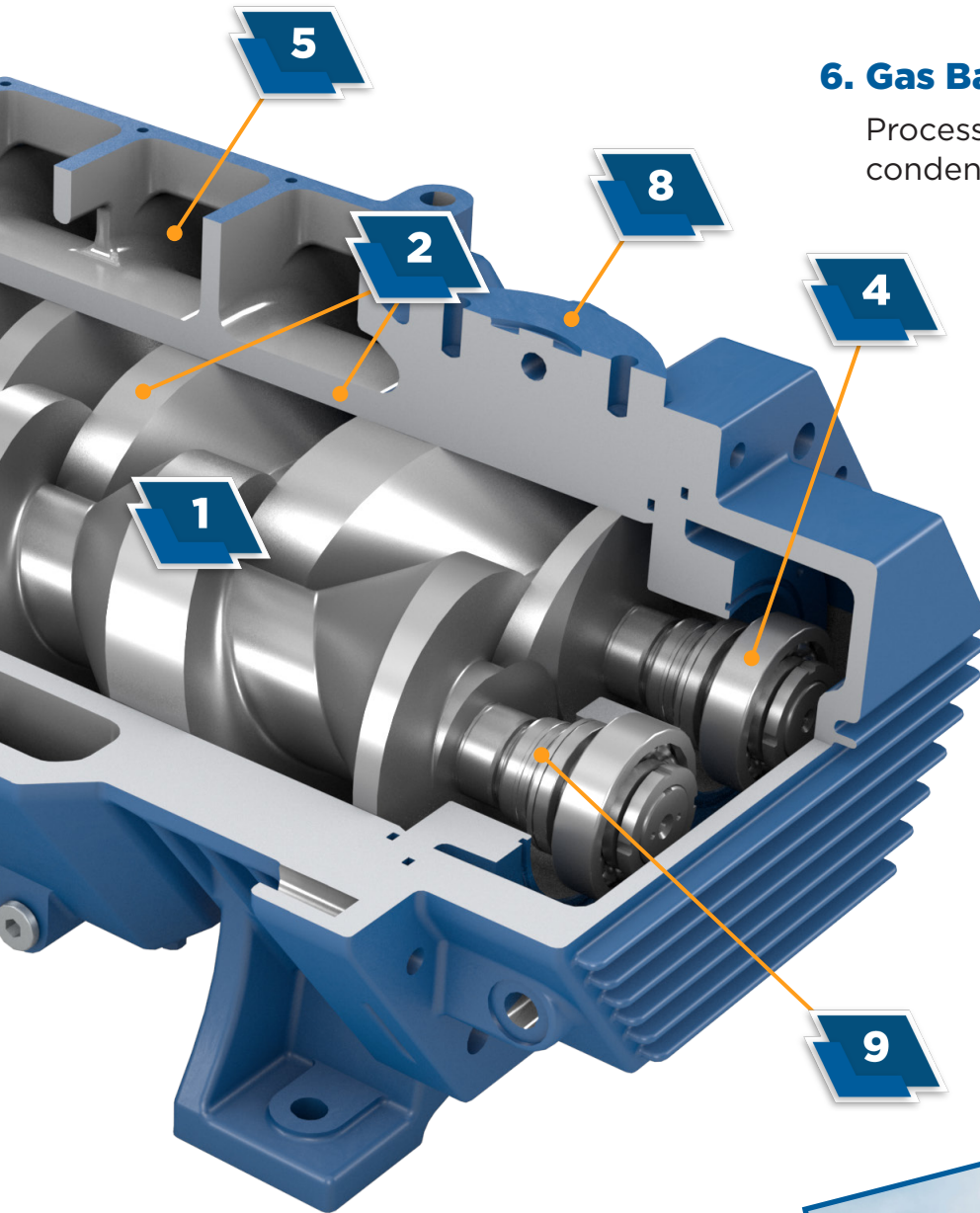

TECHNICAL DATA

VSC DRY SCREW VACUUM PUMPS		VSC-450		
		Imperial	Metric	
Process Duty	Capacity	60Hz	265 ACFM	450 m ³ /hr
		50Hz	210 ACFM	360 m ³ /hr
	Ultimate (Blank-Off) Vacuum	60Hz	<0.007 Torr	<0.01 mBar
		50Hz	<0.015 Torr	<0.02 mBar
	Continuous Back Pressure Limit - Standard		4 psig	0.3 Bar
	Installed Power - Standard		15 HP	12kW
	Power Consumption @ 10 Torr		10 HP	7.5 kW
	Weight - Bare Pump		970 lbs	440 kg
	Noise Level*		75 dB(A)	
	Inlet Connection Size - Top of Pump		2.5" ANSI B16.5, 150#	
	Exhaust Connection - Bottom of Pump		1.5" ANSI B16.5, 150#	

* With silencer.

Performance Curves

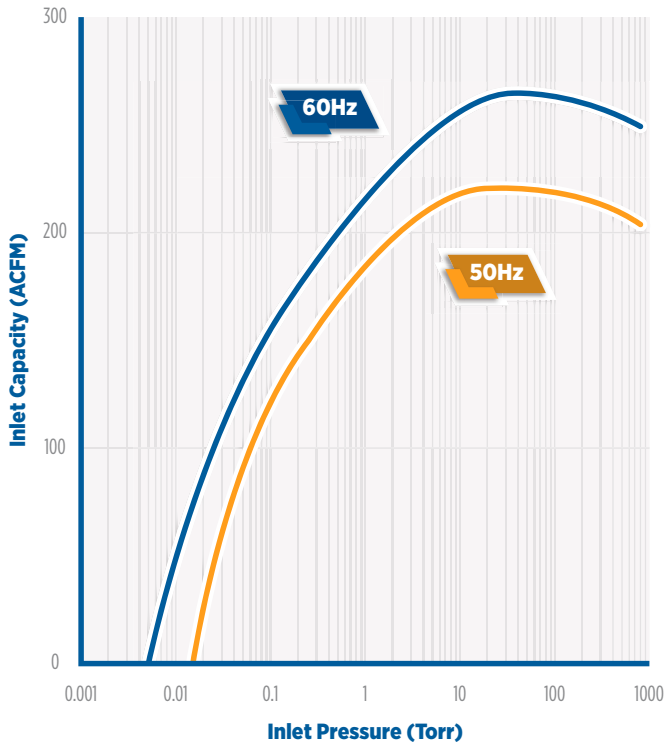

Dimensions

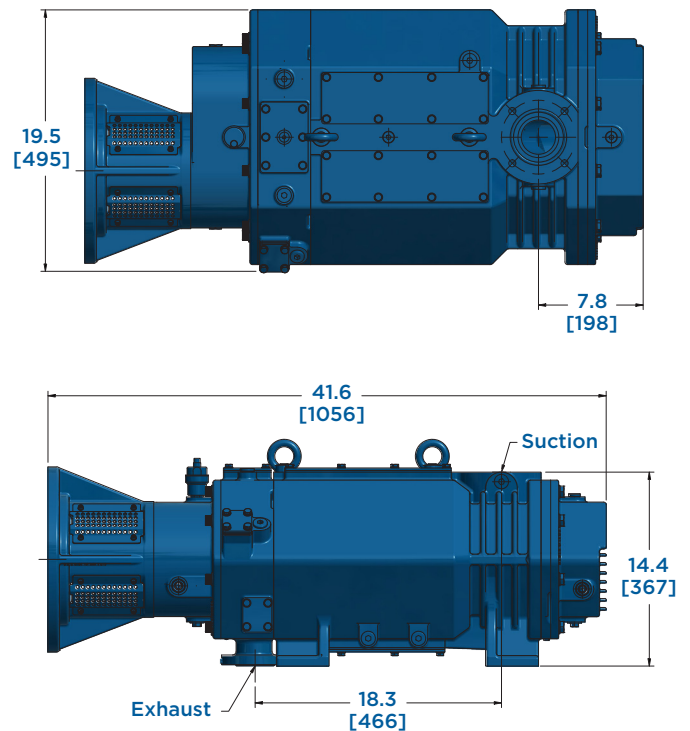

Customized Coverage

That Works For You

Choose from flexible contract term programs **ranging from 1 to 5 years**, giving you freedom to ensure consistent, reliable coverage that aligns with your business needs. Our parts and service plans offer three flexible options that can be mixed and matched to fit your unique operational needs, giving you elevated control over your support strategy.



NASH PARTS PLAN

NASH SERVICE PLAN



Annual Preventative Care

Fiberscope inspection of your Vacuum Pump or Compressor.

Spare Parts Coverage

Basic Rebuild Kits, Packing, Mechanical Seals, Dole valves, Orifice Unions and more.

Spare Parts Coverage

Basic Rebuild Kits, Packing, Mechanical Seals, Dole valves, Orifice Unions and more.

Fixed Pricing

Pricing will remain unchanged throughout the duration of the contract. Allowing for accurate budgeting for your NASH Pump and Compressor maintenance.

Fixed Pricing

Pricing will remain unchanged throughout the duration of the contract. Allowing for accurate budgeting for your NASH Pump and Compressor maintenance.

Genuine Parts

All NASH supplied parts meet our engineering and quality standards. Ensuring that your equipment has the correct parts to keep it running like new!

Genuine Parts

All NASH supplied parts meet our engineering and quality standards. Ensuring that your equipment has the correct parts to keep it running like new!



Additional Discount

Additional discount on repairs, exchanges and parts.

DURATION: 1 TO 5 YEARS

DURATION: 1 TO 5 YEARS

Ready To Get Started?

Getting started is easy; simply connect with your local Nash representative. Together, we will review your process, equipment, and goals to build a plan tailored specifically to your needs.





nashpumps.com



linkedin.com/company/nashpumps



youtube.com/@nashpumps