

HydraFLOW™

HYDRAFLOW SL_e COOLER

The Hydraflow SL_e Hydraulic Cooler is designed with a narrow profile to fit in very tight spaces and comes standard with an integrated Over Temperature Bypass Circuit.

This provides an extra protection for The Cooler and expensive hydraulic pumps, motor and other components in your hydraulic system. This system limits the maximum heat of the Hydraulic Oil and will automatically go into bypass, protecting the complete Hydraulic System.



Breather design prevents water contamination

Convenient oil fill point

Quick, easy access to filter



Temp Circuit is Standard

Narrowest unit in its class

Hydraflow is designed and assembled as a complete easy to install package.

Benefits include:

- Ideal for tractors with short wheelbases or behind the cab mounting.
- The design offers maximum hydraulic fan system airflow and efficiency
- Under 9" wide, the narrowest unit in its class
- Recessed breather design reduces water contamination
- Rear stud mount offers a flat mounting surface without mounting flanges
- Two conveniently located sight glasses, one empty and one full, show the correct oil level.



HydraFLOW™

FEATURES

- Reservoir - 2-1/2 gallon
- Flow rate - up to 25 gallons per minute
- Pressure - 3000 psi
- High pressure - 3/4" JICM "IN" 3/4" JICM "OUT"
- Low pressure return - 1" JICM
- Suction - 1-1/2" Code 61, 2" NPT
- Drain connection - 1/2"
- Weight - 85 lbs. Dry

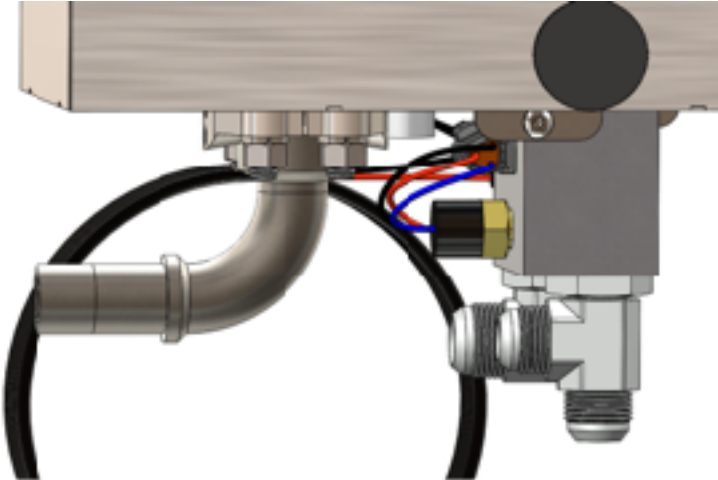

Over Temperature Bypass Circuit Shown Above

HYDRAFLOW™ APPLICATIONS

- Chemical transports
- LP Bobtails
- Maintenance trucks
- Water trucks
- Lube trucks
- Food transports

Dimensions

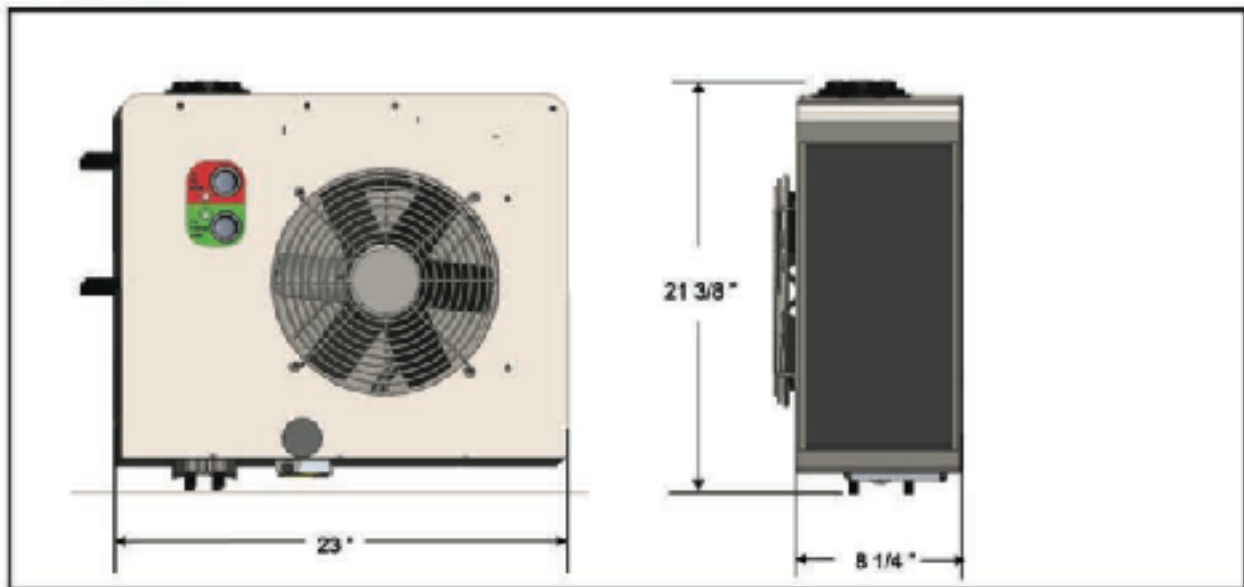

Distributed By:



Paragon Tank Truck Equipment LLC,
2111 US Hwy 411 NE
Cartersville, Georgia 30121
Tel 770-387-3820 | Toll Free 800-471-8769 | Fax 770-387-3824
www.truckblower.com | www.paragondirect.com | info@paragondirect.com
Copyright © 2016 Paragon Tank Truck Equipment LLC