

# Air Powered Man Rider™ Winch

MR150K Series

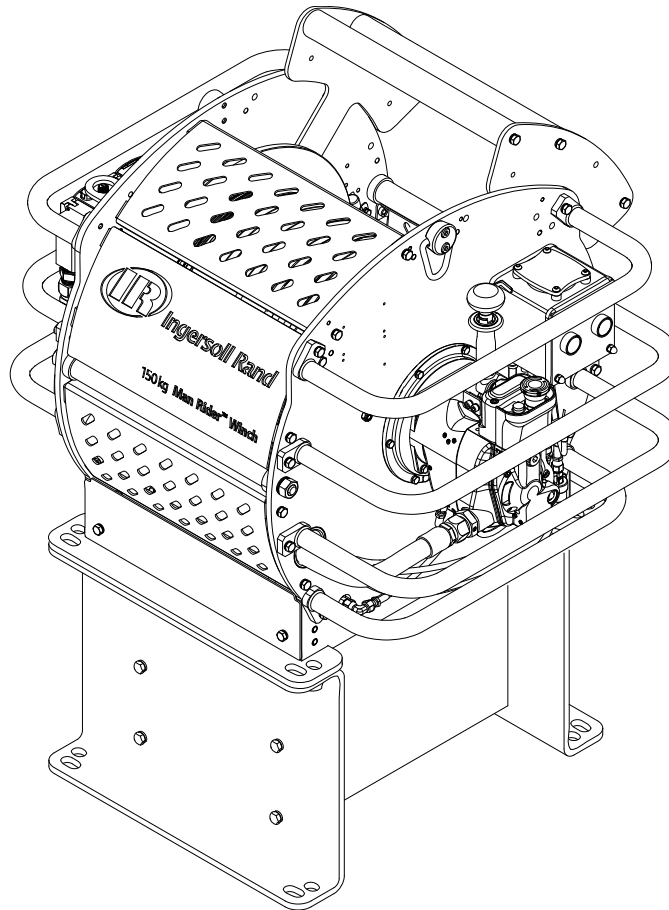

---

## Product Information



**Save These Instructions**



Form MHD56490  
Edition L  
January 2026  
CCN 45957115

Only allow **Ingersoll Rand** trained technicians to perform maintenance on this product. For additional information contact **Ingersoll Rand** factory or nearest Distributor.

For additional supporting documentation refer to **Table 1, p. 2**.

Manuals can be downloaded from [irmhdocs.skysite.com](http://irmhdocs.skysite.com)

The use of other than genuine **Ingersoll Rand** replacement parts may result in safety hazards, decreased performance and increased maintenance and will invalidate all warranties.

Original instructions are in English. Other languages are a translation of the original instructions.

Refer all communications to the nearest **Ingersoll Rand** Office or Distributor.

**Table 1. Product Information Manuals**

<b>Publication</b>	<b>Part/Document Number (CCN)</b>
Product Safety Information Manual (Man Rider)	MHD56251 (71402606)
Product Parts Information Manual	MHD56489 (45957107)
Product Maintenance Information Manual	MHD56492 (47512571)

# Table of Contents

- Product Description and Intended Use ..... 5
  - Description and Intended Use ..... 5
  - CE and ATEX Option..... 5
  - Manufacturer's Address..... 5
- Specifications ..... 6
  - Capacity Information ..... 7
  - M1 Traceability and Type Approval Certification (N4 / N5)..... 7
- Installation ..... 8
  - Mounting ..... 8
  - Air Supply ..... 9
    - Air Lines ..... 9
    - 3-Way Ball Valve..... 9
    - Air Pressure Regulator ..... 9
    - Air Line Lubricator ..... 9
    - Air Line Filter ..... 10
    - Water Separator ..... 10
    - Shut Off Valve ..... 10
  - Wire Rope ..... 10
    - Wire Rope Selection ..... 10
    - Installing Wire Rope..... 11
    - Safe Wire Rope Handling Procedure..... 11
    - Wire Rope Spooling..... 11
    - Safe Installation Procedures ..... 11
    - Rigging ..... 11
    - Rigging – Harness (riding belt) ..... 12
  - Manual Wire Rope Guide..... 12
  - Slack Line Device..... 12
  - Limit Switch Device..... 12
  - Motor ..... 13
  - Press Roller ..... 13
  - Pendent ..... 13
  - Initial Winch Operating Checks ..... 13
- Operation ..... 14
  - Training ..... 15
    - Program ..... 15
    - Planning Meeting ..... 15
  - Winch Controls..... 15
    - Winch Mounted Control ..... 15
    - Emergency Stop and Reset ..... 15
    - Overload Device ..... 16
    - Remote Pendent..... 16
  - Winch Brakes ..... 16
    - Automatic Disc Brake ..... 16
    - Automatic Drum Band Brake..... 16
  - Emergency Lowering ..... 16
    - Emergency Lowering Procedure ..... 16
    - Alternate Lifting/Lowering..... 17
  - Slack Line Device..... 17
  - Winches Not in Regular Use..... 17

## Table of Contents

---

Storing the Winch .....	17
Inspection .....	18
Wire Rope Reports .....	18
Maintenance Intervals .....	18
Frequent Inspection .....	19
Daily Inspection .....	19
Quarterly Inspection .....	20
Inspection Report .....	22
Adjustments.....	23
Overload Device.....	23
Automatic Band Drum Brake .....	23
Lubrication .....	24
Recommended Lubricants .....	24
General Lubrication.....	24
Reduction Gear Assembly .....	24
Seals and Bearings.....	24
Wire Rope.....	25
Product Information Graphics .....	26
Air Schematics (For MK2 before 11/19/2021).....	30
Air Schematics (For MK3 after 11/19/2021) .....	31
Torque Chart .....	32
Warranty .....	34

# Product Description and Intended Use

## Description and Intended Use

This product is an air power-driven winch that has a gear motor. The winches intended use is only for lifting a person (Man Rider™) in a lifting harness and shall not be used for any other purpose.

The design life of the winch is based on the environment and amount of use. At the specified maintenance interval, the winch should be subjected to a complete inspection by an **Ingersoll Rand** trained technician to determine the remaining service life. Refer to [Table 8, p. 18](#).

## CE and ATEX Option

This product is in conformity with the most recent European Standards, Classification FEM 4m.

Only models with a **CE and ATEX** marking on the data (name) plate, located on the product meet these requirements. Refer to the Product Safety and Maintenance Information Manuals for further explanation.

Figure 1. MHP4609



II 2G Ex h IIB T4 Gb X



II 2D Ex h IIIC T135°C Db X

## Manufacturer's Address

**Ingersoll Rand**  
**Douai Operations**  
529, Avenue Roger Salengro  
59450 Sin Le Noble, France  
Phone: (33) 03-27-93-08-08  
Fax: (33) 03-27-93-08-00



Table 3. Minimum and Maximum Wire Rope Size

Drum Barrel Length		Wire Rope Diameter		Cumulative Wire Rope Capacity					
				Storage Capacity			Working Capacity		
inch	mm	inch	mm	No. of Layer	ft	m	No. of Layer	ft	m
12	300	0.39	10	5	505	154	2	177	54

## Capacity Information

This product is designed for lifting with a 10:1 minimum design factor at rated load.

## M1 Traceability and Type Approval Certification (N4 / N5)

Load bearing parts are documented to provide traceability. Documentation may include chemical and physical properties of raw material, heat treating, and hardening, tensile and charpy tests as required for the part.

Type Approval Certification (N4 / N5) includes the traceability on load bearing parts as well as other requirements; any load bearing part replacement must follow the same ordering process to continue certification.

### **⚠ CAUTION**

**!**

**Requirements must be stated when reordering load bearing parts for continued certification. Refer to the Product Parts Information for specific part numbers. Material not designed for cold weather may result in damage to the product.**

# Installation

Prior to installing the product, carefully inspect it for possible shipping damage. Products are supplied fully lubricated from the factory. Check oil levels and adjust as necessary before operating product. Refer to "Lubrication," p. 24 for recommended oils and lubrication intervals.

## ⚠ WARNING

!

**Product not installed properly may fall or cause a load to fall resulting in sever injury or death. Before installation and operation of this product, refer to Product Safety Information manual and all safety warnings pertaining to this product.**

## ⚠ CAUTION

### Standards and Regulations!

**Always install, operate, inspect, and maintain this product in accordance with all applicable standards and regulations (state, country, and federal, etc.). For example in the USA, the applicable standards are American Society of Mechanical Engineers (ASME).**

## Mounting

Use the winch lifting lugs to move, position, or install the winch. Refer to "Specifications," p. 6 for the weight of the winch. If applicable, add the weight of the wire rope and other components to the winch weight.

Lift winch 3 to 4 inch (75 to 100 mm) off the ground to make sure that the winch is balanced before continuing installation.

## ⚠ WARNING

!

- **Only use the lifting lugs on the winch for lifting or moving the winch.**
- **Do not weld to any part of the winch.**
- **Do not weld the winch to a structure. Make sure that the bolts are correct size and strength to install the winch to the structure.**

1. Make sure the winch is positioned to allow for proper spooling of the wire rope onto the drum. When installed correctly, the direction of the drum for lift is clockwise as viewed from the motor end of the winch. Refer to Figure 4, p. 26.
2. The winch mounting surface must be flat and of sufficient strength to handle the rated load, plus the weight of the winch and attached equipment. An inadequate foundation may cause distortion or twisting of the winch uprights (endframes) and base resulting in winch damage.
3. Make sure the mounting surface is flat to within 0.005 inch (0.127 mm) per inch of the drum length. Shim if necessary.
4. Make sure that the winch is correctly grounded to the personal lifting system before using.
5. Use 5/8 inch (16 mm), class 8.8 or better mounting bolts. Tighten evenly and torque to 150 ft lbs (203 Nm) for dry thread fasteners. If the fasteners are plated, lubricated or a thread locking compound is used, torque to 99 ft lbs (134 Nm). Use self-locking nuts or nuts with lockwashers.
6. Refer to "Rigging," p. 11 for installation of wire rope and the Product Safety Information manual.

**Table 4. Mounting Bolt Hole Dimensions**

Mounting Style	Dimensions						Drum Length	
	A		B		C		inch	mm
	inch	mm	inch	mm	inch	mm		
FA150	20	508	18	458	0.7	18	12	300
LS-150	21	533	17.7	449				
LS2-150	22	560	16.5	420				

**Note:** Deck Mounting Holes incorporate FA150KG(i)MR, LS150RLP and LS2-150RLP Deck Mounting Patterns.

**Table 5. Winch Foundation Bolt Forces (Calculated for 1st layer stall load)**

Force Acting on Bolt		Vertical Wire Rope Entry	
		lbf	N
<b>Winch</b>	Maximum Shear Force at One Foundation Bolt Connection	114	506
	Maximum Tensile Force Shared by Rear Foundation Bolts	278	1236
<b>Pedestal</b>	Maximum Shear Force at One Foundation Bolt Connection	114	506
	Maximum Tensile Force Shared by Rear Foundation Bolts	493	2192

Refer to [Figure 5, p. 27](#).

## Air Supply

The air supply must be clean, free from moisture and lubricated to have good motor performance and life expectancy. Foreign particles, moisture and lack of lubrication are the primary causes of premature motor wear and breakdown.

The water separator, regulator, lubricator, and filter are installed as standard on the outboard end of the winch.

### ⚠ CAUTION

!

**It is recommended that a lockable isolation pressure relief valve, set to 110 - 120 psig (7.6 - 8.3 bar), be installed in the air supply line as close to the winch as possible.**

### NOTICE

!

- **Do not operate the winch without the water separator, regulator, lubricator, and filter.**
- **Warranty will be void if any part of the water separator, regulator, lubricator, and filter system is not used and maintained properly.**

## Air Lines

Inside diameter of air supply lines must not be less than size specified in [Table 2, p. 6](#). Before making final connections, all air supply lines should be purged with clean, moisture free air or nitrogen before connecting to main air inlet. Supply lines should be as short and straight as installation conditions will permit. Long transmission lines and excessive use of fittings, elbows, tees, globe valves, etc. cause a reduction in pressure due to restrictions and surface friction in lines.

## 3-Way Ball Valve

Refer to [Figure 13, p. 29](#). A 3-way ball valve is located at the air inlet to the winch. One inlet to the 3-way ball valve is to be connected to the Main Air Supply. The other inlet is available to be connected to an auxiliary air source, as needed for Emergency Lowering or Emergency Raising in the event of Main Air Supply failure. Position lever to open inlet once auxiliary air has been connected.

## Air Pressure Regulator

The air pressure regulator is install between water separator and filter. The regulator is preset and sealed at the factory and has a protective cover to ensure no adjustment to regulator is made unless necessary.

Any adjustments shall be made by an **Ingersoll Rand** trained Service Technician.

### NOTICE

!

**Not all products are CE approved, refer to products data (name) plate to see if this applies.**

## Air Line Lubricator

A lubricator is installed as standard on this winch. The lubricator should be replenished daily and set to provide 2 to 3 drops per minute of ISO VG 68 oil.

## Installation

### ⚠ CAUTION

!

**Shut off air supply before filling the lubricator.**

### Air Line Filter

An air line filter is installed as standard on the winch. The filter provides a 5 micron filtration and includes a moisture trap which is self-draining. Clean and change the filter periodically to maintain its operating efficiency.

### Water Separator

The water separator is installed as standard on the winch. A small amount of water will drain from the plug at the bottom of the housing. The filter should be replaced yearly or as necessary depending upon use.

### Shut Off Valve

Refer to the Product Safety Information Manual for information.

## Wire Rope

Follow the wire rope manufacturer's instructions. At a minimum, observe the following guidelines

### NOTICE

!

- **A requirement to maintain at least 5 tight wraps of wire rope on the drum at all times.**
- **Do not use wire rope as a ground (earth) for welding.**
- **Do not attach a welding electrode to winch or wire rope.**
- **Install wire rope to come off drum for underwound operation (normal application). Refer to MHP2450 in Product Safety Information Manual.**

### NOTICE

#### Wire rope Storage!

**Make sure to pull wire rope out of the way of moving equipment. Always stow in a slack condition.**

Install Winch so that wire rope, when at take-off angle limits, does not contact mounting surface or winch guard panels. Install winch with single part wire rope reeving only. Refer to [Figure 6, p. 27](#).

### Wire Rope Selection

Consult a reputable wire rope manufacturer or distributor for assistance in selecting the appropriate type and size of non rotating wire rope and, where necessary, a protective coating. Use a wire rope which provides an adequate safety factor to handle the actual working load and meets all applicable industry, trade association, federal, state and local regulations.

When considering wire rope requirements, the actual working load must include not only the static or dead load but also loads resulting from acceleration, retardation, and shock load. Consideration must also be given to the size of the winch wire rope drum, sheaves, and method of reeving. We recommend using an anti-rotation type steel wire rope to increase safety for operators so that while being suspended in air they won't turn. Steel wire rope must be of 10 mm diameter with a minimum breaking strength of 3372 lbs. (15 kN) right lay to assist spooling.

Refer to [Table 6, p. 10](#)

**Table 6. Wire Rope Size**

Wire Rope Anchor Part No.	Size
9631-0023 (38537445)	10 mm

**Note:** Wire rope diameter is fixed if grooved drum option is used.

## Installing Wire Rope

Refer to [Figure 7, p. 27](#).

1. Cut wire rope to length in accordance with wire rope manufacture's instructions.
2. Feed end of wire rope through drum anchor pocket hole.
3. Forming a loop, wrap loop around anchor, approximately 22 inches (559 mm) of wire rope. Ensure dead end of wire rope is facing away from the drum flange.
4. Pull wire rope anchor into position in drum anchor pocket.

## Safe Wire Rope Handling Procedure

- Always use gloves when handling wire rope.
- Never use wire rope that is frayed or kinked.
- Never use wire rope as a sling.
- Always make sure wire rope is correctly spooled and the first layer is tight against drum.
- Always follow wire rope manufacturer's recommendation on use and maintenance of wire rope.

## Wire Rope Spooling

To compensate for uneven spooling and the decrease in line pull capacity as the drum fills up, use as short a wire rope as practical. When rewinding apply tension to the end of the wire rope to eliminate line slack. This helps achieve level winding and tight spooling.

### ⚠ CAUTION

!

- **To avoid damage to the rigging, the structure supporting the rigging and the winch, do not use with a multi-reeving wire rope arrangement.**
- **Refer to DNV Standard OS E101, that provides further information regarding rigging.**

### NOTICE

!

**The limit switch will require adjustment before and after spooling to full drum storage.**

## Safe Installation Procedures

1. Do not use wire rope as a ground (earth) for welding.
2. Do not attach a welding electrode to winch or wire rope.
3. Never run wire rope over a sharp edge. Use a correctly sized sheave.
4. When a lead sheave is used, it must be aligned with center of drum. The diameter of lead sheave must be at least 18 times the diameter of wire rope. Refer to Dwg. MHP2449 in Product Safety Information Manual.
5. Requirement to maintain at least 5 tight wraps of wire rope on the drum at all times.

## Rigging

The sheave arrangement with fastening to structure shall be dimensioned according to the same principle as the winch itself. The geometry shall ensure free path for the person lifted or lowered and ensure no damage to wire rope. The geometry shall ensure that the angle between wire rope and drum or sheave is within +/- 4 degrees. The sheave arrangement shall be fitted with protection ensuring that derailing of wire rope does not occur. The diameter ratio between sheave and wire rope shall be in accordance with the manufacturer's requirements but a minimum 18:1. All fittings and connectors will have at least the breaking strength of the wire rope. For the terminations of wire ropes only splices; aluminium pressed ferrules, non-ageing steel pressed ferrules, or wedge socket anchorages may be used. U-bolt grips shall not be used as wire rope terminations for load carrying wire ropes.

**Table 7. Sheave Specifications**

Winch Series	Minimum Diameter of Sheave (mm)	Design Factor x SWL for Sheave
MR150K	200	1.5

## Installation

### Rigging – Harness (riding belt)

#### NOTICE

!

**Harnesses shall be selected in accordance with local or other regulations. As a minimum, a harness complying to en 361:2002 should be selected and shall be marked to show its compliance to this standard. The user shall follow the manufacturer's recommendations for proper use, inspection, and disposal. Also, refer to Product Safety Information Manual before operation.**

### Manual Wire Rope Guide

Only allow personnel that are physically capable of simultaneously moving the wire rope guide handle through its full travel range and operating the winch control valve to use this equipment. Use a second operator to operate the wire rope guide as necessary.

#### ⚠ WARNING

!

- **Only use manual wire rope for even spooling of unloaded wire rope.**
- **Do not use wire rope guide to force heavily loaded wire rope into position.**
- **Remove manual wire rope guide for normal operation.**
- **Keep clear of pinch points at wire rope guide pivot and where wire rope enters guide.**
- **Do not place hand(s) on any part of the manual wire rope guide other than the handle grip during wire rope spooling.**
- **Do not allow body or clothing between the travel stop and the manual wire rope guide bar. Inspect wire rope guide prior to each use, and monitor operation during use.**
- **Do not use if wire rope guide is bent or damaged. Ensure manual wire rope guide is moved the full length of the drum for even wire rope spooling.**

### Slack Line Device

The slack wire device is preset at the factory for typical take-off angle.

When slack is detected in the payout direction and the winch drum stops rotating the winch must be "RESET". Refer to "Emergency Stop and Reset," p. 15.

#### ⚠ CAUTION

!

- **Do not use slack wire device to spool wire rope onto drum.**
- **Make sure the wire rope is properly wound on the drum.**
- **The wire rope must pass underneath the rollers when coming out of the drum, so that when a tension is applied on the end of the wire rope, the slack wire device arm is lifted.**

Refer to [Figure 4, p. 26](#).

### Limit Switch Device

Refer to [Figure 6, p. 27](#).

The limit switch device limits the amount of travel for payout and haul-in of the winch wire rope. Limit switches are not intended as the primary means of stopping winch operation.

#### ⚠ WARNING

!

**It is the owner's and operator's responsibility to adjust winch operating limits prior to using the winch.**

This is a two person procedure, one to adjust the limit switch and the other to operate the winch.

1. Loosen capscrew (86) and rotate the access cover (278) up to expose the adjustment cams (264).
2. Loosen screw (263) on one of the cams (264), upper or lower. (Use a 7 mm wrench)

3. Rotate cam until the emergency stop valve is activated, causing system air to vent.
4. Hold cam adjustment screw in position and tighten screw. Do not over tighten.
5. Reset the control valve to allow air supply to flow back into the motor. Refer to [“Emergency Stop and Reset,” p. 15.](#)
6. Repeat steps 1 through 5 operations for the second cam.
7. Test the winch set points by operating winch through three complete cycles to make sure the limits are within +/- 0.5 m of set points.
8. Once settings are at the desired limits close the access cover (278) and tighten capscrews (86). Do not over tighten capscrews.

## NOTICE

!

**Activate the shut off valve and operate the winch in opposite direction at slow speed during one turn when a top or bottom limit switch is actuated.**

## Motor

For optimum performance and maximum durability of parts, provide an air supply of 70 to 100 psig (5 to 7 bar) at the flow recommended in [“Specifications,” p. 6,](#) as measured at the motor inlet. The winch should be installed as near as possible to the compressor or air receiver.

## Press Roller

Make sure the wire rope is positioned between press roller and drum barrel and spring frame, to keep press roller in tight contact with wire rope.

## Pendent

Check that all hose connections are tight and that hoses are not twisted or crimped.

Refer to [Figure 12, p. 29.](#)

Pendent lengths up to 66 ft (20 m) are available. Contact the factory for pendent lengths greater than 66 ft (20 m).

## ⚠ CAUTION

!

**To avoid damaging the pendent hose, make sure the strain relief cable, not the pendent hose, is supporting the weight of the pendent.**

## Initial Winch Operating Checks

Winches are tested for proper operation prior to leaving the factory. Before the winch is placed into service the following initial operating checks should be performed.

1. When first running the motor inject a small amount of light oil into the main inlet connection to provide initial lubrication.
2. Operate the winch in both directions with no load for a few minutes.
3. Check operation of limit switches, locking mechanisms and all safety devices when equipped.
4. Check foundation mounting fasteners are secure.
5. Check wire rope does not come in contact with the guard.

For winches that have been in storage, the following start-up procedures are required:

1. Give the winch an inspection conforming to requirements of [“Winches Not in Regular Use,” p. 17.](#)
2. Check oil levels in reduction gear and disc brake, top off levels as required.
3. Pour a small amount of ISO VG32 (SAE 10w) oil in motor inlet port.
4. Operate motor for 15 seconds in both directions to flush out any impurities.
5. The winch is now ready for normal use.

# Operation

It is recommended that the user and owner check all appropriate and applicable regulations before placing this product into use. Refer to Product Safety Information Manual before operating product.

The four most important aspects of winch operation are:

1. Follow all safety instructions when operating the product.
2. Allow only people trained in safety and operation of this winch to operate this equipment.
3. Subject each product to a regular inspection and maintenance procedure.
4. Be aware of product capacity and weight of load at all times.

## **⚠ WARNING**

**!**

**Do not lift loads over people.**

## **⚠ CAUTION**

**!**

**Make sure the limit switch operates correctly and the man-riding device does not come into contact with the sheave.**

## **NOTICE**

**!**

**Refer to the Product Parts manual for MHP drawings unless specified on a page in this manual.**

Operators must be physically competent. Operators must not have a health condition which might affect their ability to act, and they must have good hearing, vision and depth perception. The winch operator must be carefully instructed in his duties and must understand the operation of the winch, including a study of the manufacturer's literature. The operator must thoroughly understand proper methods of hitching loads and must have a good attitude regarding safety. It is the operator's responsibility to refuse to operate the winch under unsafe conditions.

1. Lifting and lowering speeds are operator controlled and should be as slow as practical. Ingersoll Rand recommends that you do not exceed 100 ft (30 m) per minute. Any applicable codes and standards should be followed.
2. Personnel being lifted or lowered must be alert to obstacles and hazards during movement.
3. A personnel platform should not be used due to winches rated load.
4. Tag lines shall be used where practical.
5. The winch operator shall remain at the controls at all times when handling personnel.
6. Handling of personnel shall be discontinued upon indication of any impending danger.

## **⚠ WARNING**

**!**

**Maintain at least 5 wraps of wire rope on the drum at all times.**

7. The man riding device shall be raised approximately 1 ft (30 cm) and inspected to ensure that it is secure prior to personnel occupancy. Before raising or lowering personnel, the following conditions shall exist:
  - a. Wire rope shall be free of kinks.
  - b. Winch shall be reeved for single part line which avoids obstructions and interference.
  - c. The primary point of wire rope attachment shall be centered over the man riding device to reduce tilting and swinging the suspended person.
8. When personnel are suspended, a signal person must be provided unless operator has line of sight. Signals must be visible to the operator at all times.
9. Rider suspension devices shall be in accordance with all applicable codes and regulations, such as ISO-EN 361 (harness, wire, pulleys..).
10. Bridles and associated hardware for the man riding device shall not be used for any other service.
11. If a slack wire rope condition occurs the hoisting mechanisms shall be inspected to assure wire rope is properly spooled onto drum and through sheaves. When slack wire has been detected, operator must determine and rectify problem prior to resuming operation.

## Training

### Program

The employer shall provide and implement a training program for all supervisors and employees engaged in the operation of raising, lowering or suspending personnel using proper suspension devices from a winch load line so that they are familiar with the requirements of the hoisting system and are able to recognize the associated hazards and take appropriate measures. Records of training programs shall be maintained.

### Planning Meeting

A meeting attended by the winch operator, signal persons, persons to be lifted and the person in charge of the task to be performed is required to be held to plan and review the procedures to be followed, including procedures for entering and leaving the man riding device, the use of safety equipment, signals, and the lift chart information.

### NOTICE

!

**This meeting shall be held prior to the beginning of personnel-hoisting operations at each new work location and thereafter for any new employees assigned to the operation.**

## Winch Controls

The throttle control provides the operator control of the motor speed and direction of the drum rotation.

Prevent sudden movements of the control valve. Sudden movement of the control valve may activate the overload device. If this occurs reset the winch by pressing the "ON" button of the emergency stop device and smoothly action the control valve. Make sure the winch is not overloaded.

### Winch Mounted Control

Refer to [Figure 8, p. 28](#).

Refer to the label on the winch for take-off angle part number 45972643.

#### Vertical Wire Rope Take-off Angle (standard):

The operator should stand to the left of the motor and the slack arms should be facing away. The control lever is a lift and shift; to haul-in, lever is shifted towards operator and the drum rotates clockwise. To payout, lever is shifted away from operator and the drum rotates counterclockwise.

### NOTICE

!

**For Horizontal take-off angle, the winch will require some adjustments to the control valve, slack wire assembly and winch guard. Contact the authorized service center for instructions.**

## Emergency Stop and Reset

Refer to [Figure 8, p. 28](#).

The emergency stop button is located at air inlet of winch on local control models, and on pendant on remote control models. When activated, winch drum rotation will immediately cease.

1. To start winch operation depress the "RESET" button.
2. Operate the lift and shift control lever to either 'Haul-in' or 'Payout' .
3. In event of an emergency all winch operation can be stopped by pushing the emergency stop button. This will prevent air from reaching winch motor, engage winch automatic brake(s) and stop winch haul-in or payout movement.
4. To reset Emergency Stop Valve:
  - a. Rotate the emergency stop button clockwise to allow the button to "pop up".
  - b. Depress and hold until the "RESET" button until the air escape through the cover plate area on the motor end.

## Operation

### Overload Device

#### ⚠ WARNING

!

**This overload protection device is factory set at 125% maximum of the SWL at rated layer. Refer to Specifications, p. 6.**

The overload device is integrated into the winch air motor and prevents the winch from lifting a load greater than the winch nominal overload setting. When an overload is detected, inlet supply air is stopped and the winch will not operate. If the overload device is activated the load must be lowered and reduced. Alternative methods should be used to accomplish the task. Refer to "Emergency Stop and Reset," p. 15. To lower the load, first reset the winch by pressing the "RESET" button of the emergency stop valve and operate the winch control for wire rope payout.

### Remote Pendant

Refer to [Figure 12, p. 29](#).

Provides remote winch control at distance up to 20 meters (66 ft) away from the winch motor. Pilot air hoses connect the pendant to the winch motor to provide winch operation. The pendant control throttle is a two lever movable control station. Direction of winch drum rotation is determined by the pendant control lever depressed.

## Winch Brakes

### Automatic Disc Brake

The automatic disc brake is a spring applied, air released brake. When the control valve is in the neutral position, the air in the brake is vented and the brake is engaged. The springs, acting on the pressure plate, compress the brake friction and separator plates and engage the brake to prevent drum rotation.

### Automatic Drum Band Brake

The automatic drum band brake is a spring applied, air released, externally mounted brake. When the control valve is placed in the neutral position, the air in the cylinder is vented allowing the spring tension to automatically engage the brake and prevent drum rotation.

## Emergency Lowering

This device allows the person to be lowered safely in case of main air supply failure.

**Note:** Recommended minimum load for Emergency Lowering is 200 lbs (91 kg).

#### ⚠ WARNING

!

- **This is a two person procedure, one person to operate the emergency lowering device, the other to maintain a line of sight on the person being lowered.**
- **The winch must be isolated from the main supply air system during this operation. Make sure the Emergency Stop button is pressed down and latched in the OFF position.**
- **Communication must be established between the lifted person and winch operators. Operators should be able to visually monitor lifted person until landed.**
- **If line of sight between operators and lifted person is not possible, signals must be conveyed to the operators.**

### Emergency Lowering Procedure

Refer to [Figure 10, p. 28](#).

1. In the event of air supply failure, press the Emergency Stop button to the down and latched OFF position.
2. Actuate and hold the switch nearer to the motor. Switch #1 on [Figure 10, p. 28](#). This will release the Disc Brake. Then actuate the switch further from the motor. Switch #2 on [Figure 10, p. 28](#). This will release the Band Brake. Toggle this switch as necessary to control the descent of the person, while continuing to hold Switch #1 in the actuated position.
3. The signal-person shall maintain the line of sight of the person being lowered to make sure the person is not being entangled in wire rope or other equipment on the rig. The signal person shall alert the operator to release Switch #2 to stop lowering temporarily to avoid hazards, as necessary.
4. Continue to hold both the switches in the actuated position in order to lower the person safely to the ground.

**NOTICE****!**

**After each use of the emergency lowering device, reset the Emergency Stop Valve and verify the main air supply is in proper working condition and able to fulfill its task.**

**Alternate Lifting/Lowering**

The following information is provided to allow for emergency lowering or lifting of a person if air supply is lost to winch. These procedures should be used if no other method of safely lowering personnel is available.

**Three-Way Valve**

Refer to [Figure 13, p. 29](#)

This device allows the person to be moved the shortest way to safety in case of normal air supply failure. In the event of air supply failure, operate the three way valve from normal air supply to the emergency inlet. For a single emergency lifting or lowering, a 50 liter bottle of compressed air at minimum pressure (5 to 7 bar) can be used.

1. Open the emergency power source. Rotate valve lever towards normal inlet air supply side.
2. Make sure that the downstream pressure is 5 to 7 bar.
3. Operate winch normally for lifting or lowering the person the shortest way to safety.

**NOTICE****!**

**After each operation of emergency lifting/lowering system, return the three-way valve to the main air inlet and verify the main air supply is in proper working condition and able to fulfil its task.**

**Slack Line Device**

Refer to [Figure 4, p. 26](#).

The slack wire rope device is intended to detect slack in the wire rope during time of operation in the payout direction.

When lowering, in the event of slack, the slack wire device arm will lower by its own weight and activate a pneumatic switch that stops the pilot air lowering signal to the motor. The winch is then stopped with both brakes applied.

**Winches Not in Regular Use**

1. Equipment which has been idle for a period of one month or more, but less than six months, shall be given an inspection conforming to the requirements of ["Frequent Inspection," p. 19](#) before being placed in service.
2. Equipment which has been idle for a period of over six months shall be given a complete inspection conforming with the requirements of 'Periodic Inspection' before being placed in service. Refer to Product Maintenance Information Manual.
3. Standby equipment shall be inspected at least semi-annually in accordance with the requirements of ["Frequent Inspection," p. 19](#). In abnormal operating conditions equipment should be inspected at shorter intervals.
4. All oils must be drained and replaced with new, and all grease cavities shall be packed to the prescribed limit. Refer to ["Lubrication," p. 24](#). Product must be operated for at least 15 seconds in both directions with well lubricated, dry air.

**Storing the Winch**

1. Always store the winch in a no load condition.
2. Wipe off all dirt and water.
3. To prevent rust build up from internal condensation, open lubricator to allow more oil into winch and operate with no load. If the winch is being stored away from and not connected to the main air supply, place small amount of ISO VG32 or SAE 10W oil at air inlet port.
4. Oil the wire rope.
5. Place in a dry location.
6. Before returning winch to service, follow instructions for ["Winches Not in Regular Use," p. 17](#).

# Inspection

Inspection information is based in part on American Society of Mechanical Engineers Safety Codes (ASME B30.7).

## ⚠ WARNING

!

- **All new or repaired equipment should be inspected and tested by Ingersoll Rand trained Technicians to make sure of safe operation at rated specifications before placing equipment in service.**
- **Never use a winch that inspection indicates is damaged.**

Frequent and periodic inspections should be performed on equipment in regular service. Frequent inspections are visual examinations performed by operators or **Ingersoll Rand** trained Inspectors and include observations made during routine equipment operation. Periodic inspections are thorough inspections conducted by **Ingersoll Rand** trained Technicians. ASME B30.7 states inspection intervals depend upon the nature of the critical components of the equipment and the severity of usage. Careful inspection on a regular basis will reveal potentially dangerous conditions while still in the early stages, allowing corrective action to be taken before the condition becomes dangerous.

Deficiencies revealed through inspection, or noted during operation, must be reported to designated personnel to make sure that corrective action is taken.

A determination as to whether a condition constitutes a safety hazard(s) must be decided, and the correction of noted safety hazard(s) accomplished and documented by written report before placing the equipment in service.

## Wire Rope Reports

Records should be maintained as part of a long-term wire rope inspection program. Records should include the condition of wire rope removed from service. Accurate records will establish a relationship between visual observations noted during frequent inspections and the actual condition of wire rope as determined by periodic inspections.

## Maintenance Intervals

**Table 8. Maintenance Intervals Chart**

Severe Application						
The following work can be completed by owner maintenance personnel						
System Air Filter	Inspect system air filter every 30 days.					
Water Separator	Inspect system filter every 30 days.					
Grease Fittings	Lubricate grease fittings every 90 days.					
It is recommended that the following work be completed by an Ingersoll Rand trained service technician or a Qualified Person.						
Standard Components	1 year	2 years	3 years	4 years	5 years	6 years
Inspect Motor			X			X
Inspect Disc Brake			X			X
Inspect Gearbox			X			X
Replace Winch Anchor Bolts			X			X
Inspect Control Valve	X	X	X	X	X	X
Inspect Drum, Housings and Main Frames			X			X
Drum Shaft			X			X
Overload Device	X	X	X	X	X	X
Limit Switches	X	X	X	X	X	X
Emergency Brake Release	X	X	X	X	X	X
Automatic Band Brake <sup>(a)</sup>	X	X	X	X	X	X
Load Test	X	X	X	X	X	X

<sup>(a)</sup> Do not disassemble Auto Band Brake Air Cylinder unless brake operation or visual inspection indicates a requirement.

**NOTICE****Winch Load Test!**

**Do an annual winch load test for all applications.**

**NOTICE**

!

- **Annual Inspection and Load test shall be performed by an Ingersoll Rand Trained Technicians unless directed otherwise by a \*Qualified Person.**
- **Certification shall be done in every three years by an Ingersoll Rand Trained Technicians unless directed otherwise by a \*Qualified Person.**

\* Qualified Person: A person who, by possession of a recognized degree in an applicable field or certificate of professional standing, or who by extensive knowledge, training, and experience has successfully demonstrated the ability to solve or resolve problems relating to the subject matter and work.

**Frequent Inspection**

On equipment in continuous service, a 'Daily Inspection' should be made by the operator at the beginning of each shift and a 'Quarterly Inspection' should be conducted by an **Ingersoll Rand** trained Inspector or Qualified person every 90 days and a record of the inspection maintained.

**Daily Inspection**

Complete inspections prior to start of daily tasks. Conduct visual inspections during regular operation for indications of damage or evidence of malfunction (such as abnormal noises).

1. **Lubricator:** Adjust air line lubricator drops 2 to 3 per minute of ISO VG 32 (SAE 10W) oil during winch operation.
2. **Surrounding Area:** Visually check for winch oil leaks. Do not operate winch if leaking oil is found. Make sure the surrounding area has no slippery surfaces and is obstruction free.
3. **Hoses and Fittings:** Visually inspect for damage, air leaks, and loose connections. Repair all leaks or damage and tighten loose connections prior to starting daily tasks.
4. **Wire Rope Anchor:** Verify wire rope anchor is securely installed.
5. **Guards:** Verify wire rope does not contact drum guard during winch operation and that guards are secure and undamaged.
6. **Winch:** Visually inspect winch housings, control(s), external brake, siderails, uprights and drum for damage. Check that all external bolts are in place and secure. Report damage to supervisor and request additional inspection by an **Ingersoll Rand** trained Service Technician.
7. **Mounting:** Visually inspect winch mounting bolts. Check bolts are tight, undamaged and free of corrosion.
8. **Winch Operation:** Power winch in both directions. Winch must operate smoothly without sticking, binding or abnormal noises and have minimal vibration.
9. **Control Valve or Pendant:** Check operation is smooth and winch is responsive to control device movement. Check control returns to neutral when released. If winch responds slowly or control sticks. Winch is to operate without hesitation in both the payout and haul-in directions.
10. **Motor:** During operation check motor housing for excess heat build up. Housing should not be hot to touch. Listen for grinding or knocking noises. If excess heat or noises are noted, do not operate until inspected by an **Ingersoll Rand** trained Technician.
11. **Wire Rope Spooling:** Visually check reeving and make sure the wire rope feeds on and off the drum smoothly. Verify spooling direction is correct for winch and application.
12. **Brakes:** Lift and lower the load a short distance to test brakes. Brakes must hold load without slipping. Automatic brake must release when winch control throttle is operated. If brakes do not hold load or do not release properly, they must be adjusted or repaired.

**⚠ WARNING****Brakes!**

**Worn or improperly functioning brakes may cause excessive heat build up and sparks.**

13. **Wire Rope:** Visually inspect all wire rope expected to be in use during the day's operations. Inspect for wear and damage indicated by distortion of wire rope such as kinking, "birdcaging", core protrusion, main strand displacement, corrosion, broken or cut strands. If damage is evident, do not operate winch until the

## Inspection

discrepancies have been reviewed and inspected further by personnel knowledgeable on wire rope safety and maintenance procedures.

### NOTICE

#### Periodic Inspection!

**The full extent of wire rope wear cannot be determined by visual inspection. At any indication of wear inspect wire rope in accordance with instructions in "Periodic Inspection".**

14. **Limit Switches:** Make sure the limit switches engage and prevent operation at the required set point and with drum rotating in the correct direction. Make sure the limit switch properly resets.
15. **Emergency Stop and Reset Valve:** Activate emergency stop in payout and haul-in directions to ensure proper operation. Valve must stop winch operation and brakes must set quickly. Reset valve after test.
16. **Slack Line Detection:** Operate winch in payout direction until slack line valve actuates. Ensure winch stops operating in lowering direction, but can still lift load, after emergency stop reset.
17. **Emergency Lowering Device:** Check the pressure gauge located on the emergency lowering enclosure to ensure tank has the proper psi supply of air. Do not operate the winch if there is no air supply in the tank.
18. **Press Roller:** Make sure the wire rope is positioned between press roller and drum barrel and springs keep press roller in tight contact with wire rope. Make sure of smooth and proper operation.
19. **Labels and Tags:** Check for presence and legibility. Replace if necessary.

#### Quarterly Inspection

Complete a 'Quarterly Inspection' on a recurring basis to provide regular winch monitoring.

In addition to the requirements of 'Daily Inspection' also inspect the following:

1. **Power Supply:**
  - a. Inlet air pressure to the winch is 70 to 100 psig (5 to 7 bar) at full throttle with nominal system usage.
  - b. Water separator, regulator, filter, and lubricator are installed and functioning.
  - c. Air filter is clean, drain if necessary.
  - d. Air supply regulator is showing correct supply pressure.
2. **Rigging:**
  - a. Correct size wire rope is being used, 7/16 inch (10 mm) maximum.
  - b. Wire rope take-off angle is within design limits.
3. **Visual Integrity:**
  - a. All Components - Inspect for wear, damage, distortion, deformation and cleanliness. If external evidence indicates damage, contact an **Ingersoll Rand** trained Service Technician to disassemble as required to conduct a detailed inspection.
  - b. No part of the winch has been welded onto.
  - c. Fasteners - Check external retainer rings, split pins, capscrews, nuts and other fasteners on winch, including mounting bolts.
  - d. Drum and Sheaves - Check for cracks, wear or damage.
  - e. Press Roller - Inspect for wear. Make sure the press roller spring keeps tight contact with wire rope.
  - f. Slack Line Detector - Inspect rollers for wear and grooves. Make sure the rollers freely rotate.
  - g. Make sure the winch and drum guarding is installed.
  - h. No modifications have been performed on the winch.
  - i. Check motor, gearbox and disc brake for oil leakage.
4. **Labeling / Marking:**
  - a. Data (name) plate is attached and legible.
  - b. Warning tags and labels are attached, legible and in correct places on winch.

**5. Wire Rope Spooling:**

- a. A minimum of 5 dead wraps remain on the drum in full pay-out position.
- b. Proper freeboard is maintained at full haul-in position (minimum 1 inch (26 mm) for 10 mm wire rope).
- c. Wire rope is properly lubricated.

**6. Operational Checks:**

- a. Limit Switches - Operate winch in the haul-in direction until limit switch engages. Make sure the winch stops operating in haul-in direction, and operates in payout. Operate winch in payout direction until limit switch engages. Make sure the winch stops operating in payout direction, and operates in haul-in direction.
- b. Line Speed - Raise and lower 5 ft (minimum distance) a 68 lb (150 kg) load at first layer to verify line speed. Line speed to be 98 fpm (30 m/min). Line speed to be recorded after warm-up.

# Inspection Report

Make a photo copy of this form and use as an inspection record.

Ingersoll Rand MR150K Series Air Winches					
<b>Model Number:</b>				<b>Date:</b>	
<b>Serial Number:</b>				<b>Inspected by:</b>	
<b>Reason for Inspection: (Check Applicable Box)</b>					
1. Scheduled Periodic Inspection: ( ____ Months ____ Years) 2. Discrepancy(s) noted during Frequent Inspection 3. Discrepancy(s) noted during maintenance 4. Other: _____				<b>Operating Environment:</b> Normal ____ Heavy ____ Severe ____	
Refer to the Product Information Manual and Product Parts Information Manual and "Inspection," p. 18 for general inspection criteria. Also, refer to appropriate National Standards and Codes of practice. If in doubt about an existing condition, contact the nearest <b>Ingersoll Rand</b> Distributor or the factory for technical assistance.					
Component	Condition		Corrective Action		Notes
	Pass	Fail	Repair	Replace	
Uprights and Siderails					
Drum Band Brake					
Disc Brake					
Drum Band Brake (Visual Inspection)					
Disc Brake (Visual Inspection)					
Motor					
Controls					
Limit Switches					
Air System					
Fasteners			—		
Emergency Stop Valve					
Overload Device			—		
Reduction Gears					
Labels and Tags			—		
Shafts					
Winch Guard					
Wire Rope Wedge			—		
Emergency Lowering Device			—		
Slack Line Device			—		
Press Roller					
Wire Rope			—		
Other Components (list in Notes section)					

# Adjustments

## Overload Device

### ⚠ WARNING

!

Overload is factory set and sealed with red paint and should not be adjusted without consulting an Ingersoll Rand trained technician.

Figure 2. MHP2683

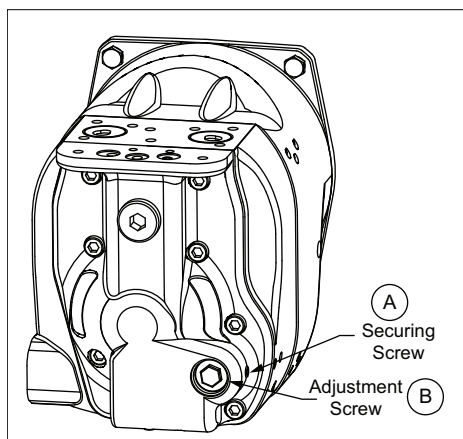

1. Connect winch to an air supply.
2. Release securing screw and adjusting screw in order to increase or decrease the SWL (increase SWL by tightening the adjusting screw). Adjustment must be made for an overload of 125% maximum of SWL.
3. Tighten securing screw.
4. Check winch operation at rated load. If necessary, repeat adjustment.

## Automatic Band Drum Brake

1. Loosen locknut 'B'.
2. Tighten nut 'A' until the adjustment dimension 0.43 to 0.51 inch (11 to 13 mm) is achieved.
3. Tighten locknut 'B'.
4. Check brake operation.

Figure 3. MHP2880

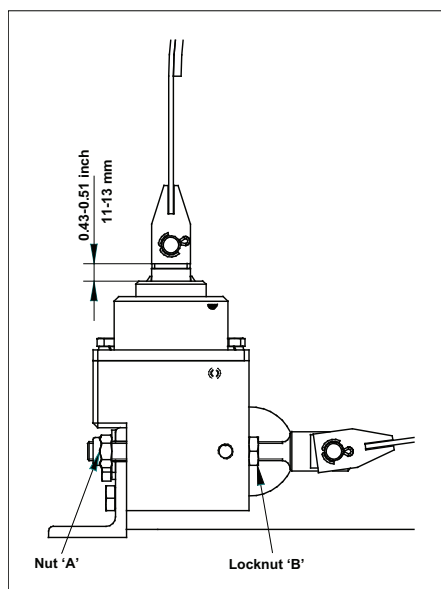

# Lubrication

To ensure continued satisfactory operation of winch, all points requiring lubrication must be serviced with correct lubricant at proper time intervals as indicated for each assembly.

Use only those lubricants may affect product performance. Approval for use of other lubricants must be obtained from your **Ingersoll Rand** distributor. Failure to observe this precaution may result in damage to winch and/or its associated components.

**Table 9. Lubrication Intervals**

Component	Interval
Check Air Line Lubricator	Daily
Change Gearbox Oil	5 years or during Winch Overhaul

## Recommended Lubricants

**Table 10. Air Motor Recommended Lubricant Grade**

Temperature	Grade Type
From -4° to 80° F (-20° to 27° C)	ISO VG 32 (SAE 10W) <sup>(a)</sup>
Above 80° F (27° C)	ISO VG 100 (SAE 30W)

<sup>(a)</sup> Units are shipped from factory with ISO VG 32 (SAE 10W) lubricant.

**Table 11. Recommended Grease Grade**

Temperature	Grade Type
-20° to 50° F (-30° to 10° C)	EP 1 mutlipurpose lithium based grease
30° to 120° F (-1° to 49° C)	EP 2 mutlipurpose lithium based grease

## General Lubrication

### ⚠ WARNING

!

**Pneumatic Winches use oil to prevent excessive heat build up and to prevent wear that could cause sparks. Oil levels must be properly maintained.**

Winches are supplied from the factory filled with oil.

Always collect lubricants in suitable containers and dispose of in an environmentally safe manner.

### Reduction Gear Assembly

Replace the oil in the reduction housing every 5 years or during Winch Overhaul. If the winch is used at a normal frequency, the oil in the reduction housing is suitable for one year operation without being changed. However, when the winch is used at a high frequency, the oil may need to be changed more often.

For correct performance, highest efficiency and long life, it is essential that the lubricating oil be at the correct level. The recommended grade of oil must be used at all times since the use of unsuitable oil may result in excessive temperature rise, loss of efficiency and possible damage to the gears.

Use only synthetic oil, Motultech SY150 which is VG 150 Grade or SAE 85W90 gearbox oil.

### Seals and Bearings

If winch is disassembled, clean all parts thoroughly and coat bearings and seals with clean grease. Use sufficient grease to provide a good protective coat.

## Wire Rope

Follow the wire rope manufacturer's instructions. At a minimum, observe the following guidelines.

1. Clean with a brush or steam to remove dirt, rock dust or other foreign material on the surface of the wire rope.

### ***NOTICE***

#### **Wire Rope Cleaning Fluids!**

**Do not use an acid-based solvent. Only use cleaning fluids specified by the wire rope manufacturer.**

2. Apply a wire rope lubricant.
3. Brush, drip or spray lubricant weekly, or more frequently, depending on severity of service.

# Product Information Graphics

Figure 4. MHP3378

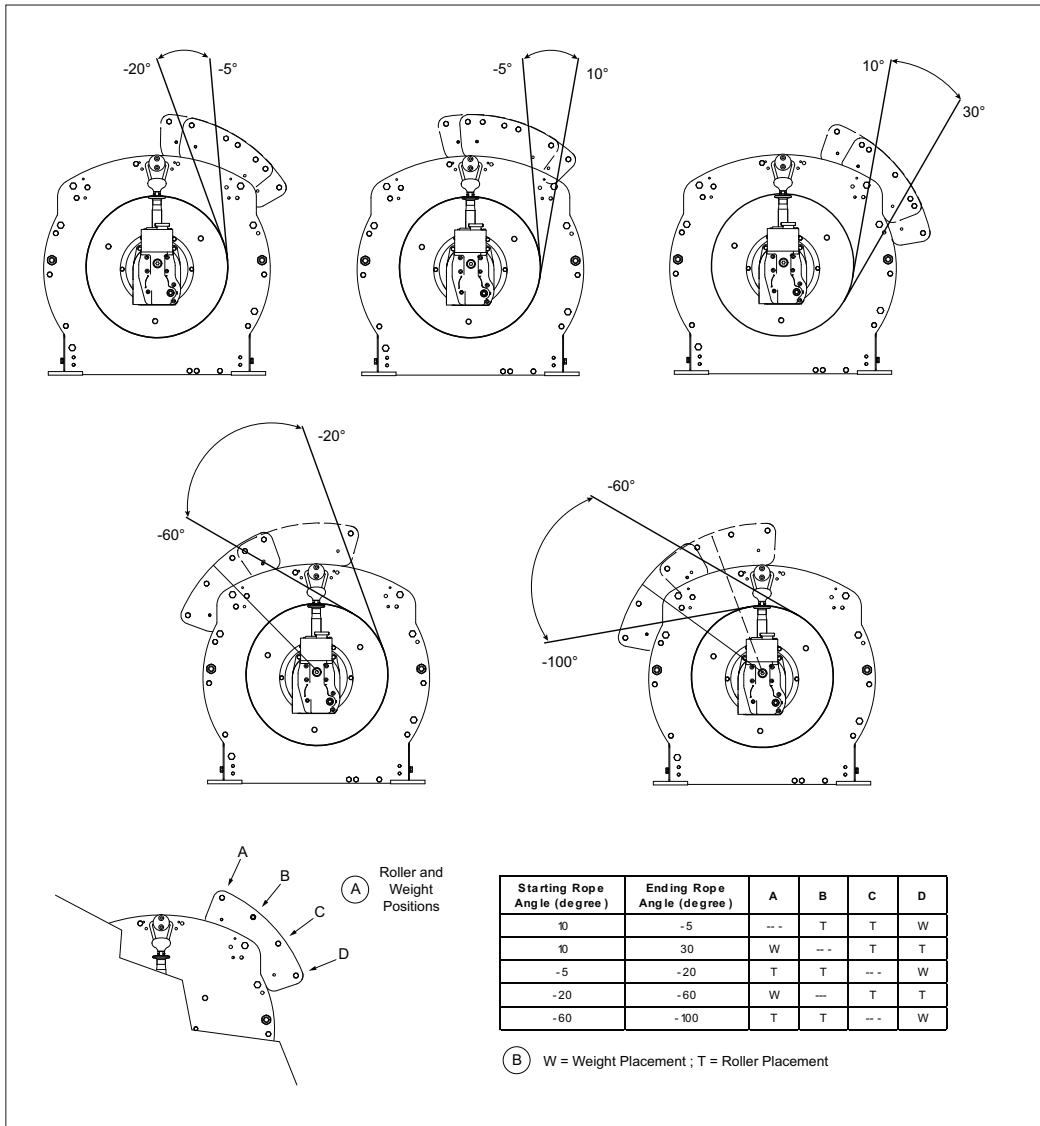

Figure 5. MHP4327

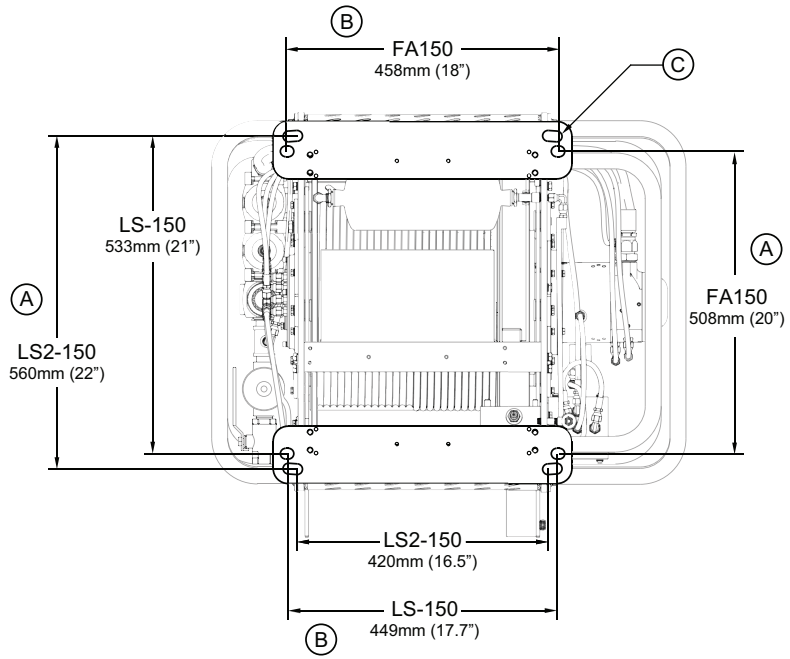

Figure 6. MHP3622

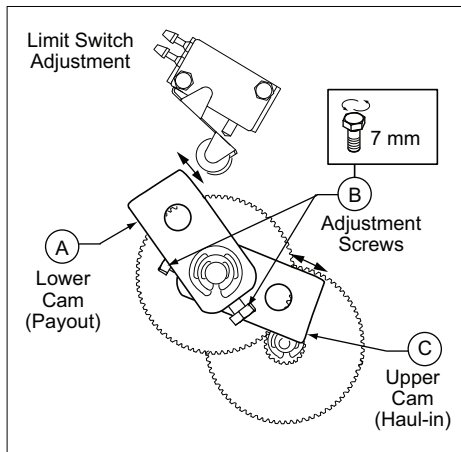
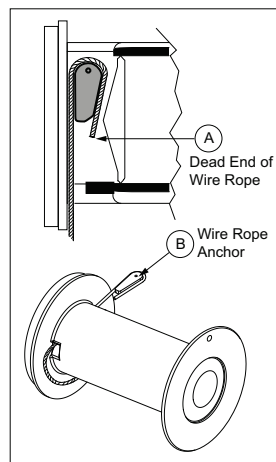
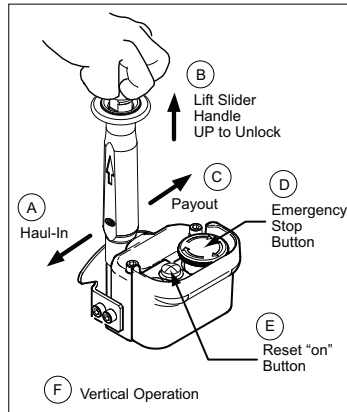

Figure 7. MHP3380



# Product Information Graphics

**Figure 8. MHP3381**



**Figure 9. MHP3383 (For MK1 before 2017)**

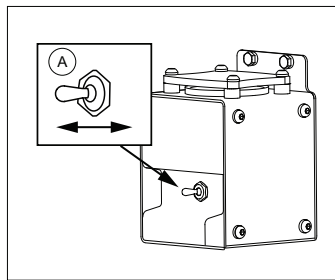

**Figure 10. MHP3795 (For MK2 before 11/19/2021)**

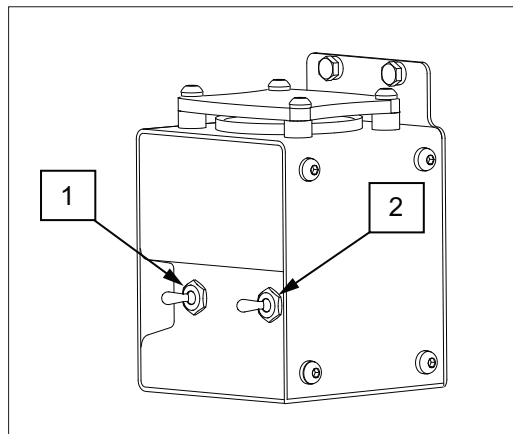

**Figure 11. MHP4610 (For MK3 after 11/19/2021)**

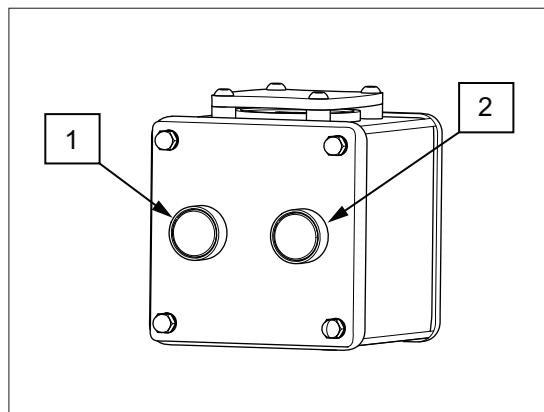

Figure 12. MHP1892

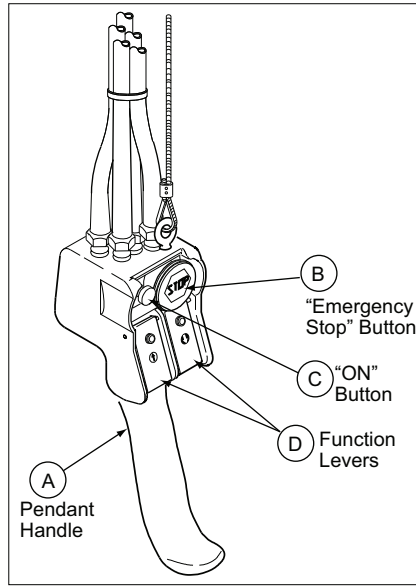
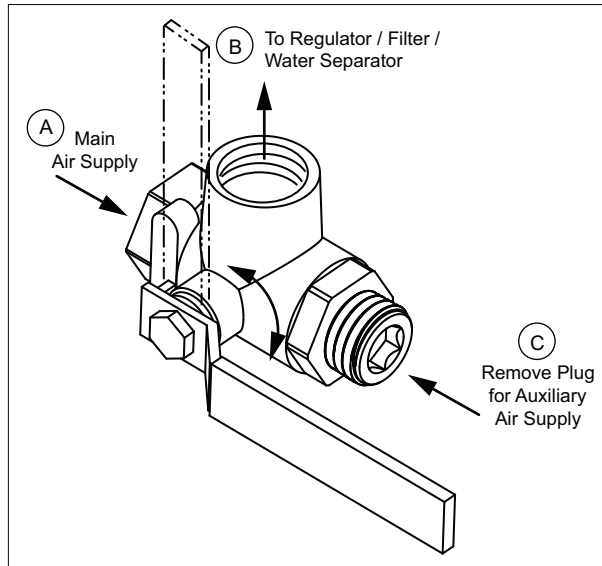
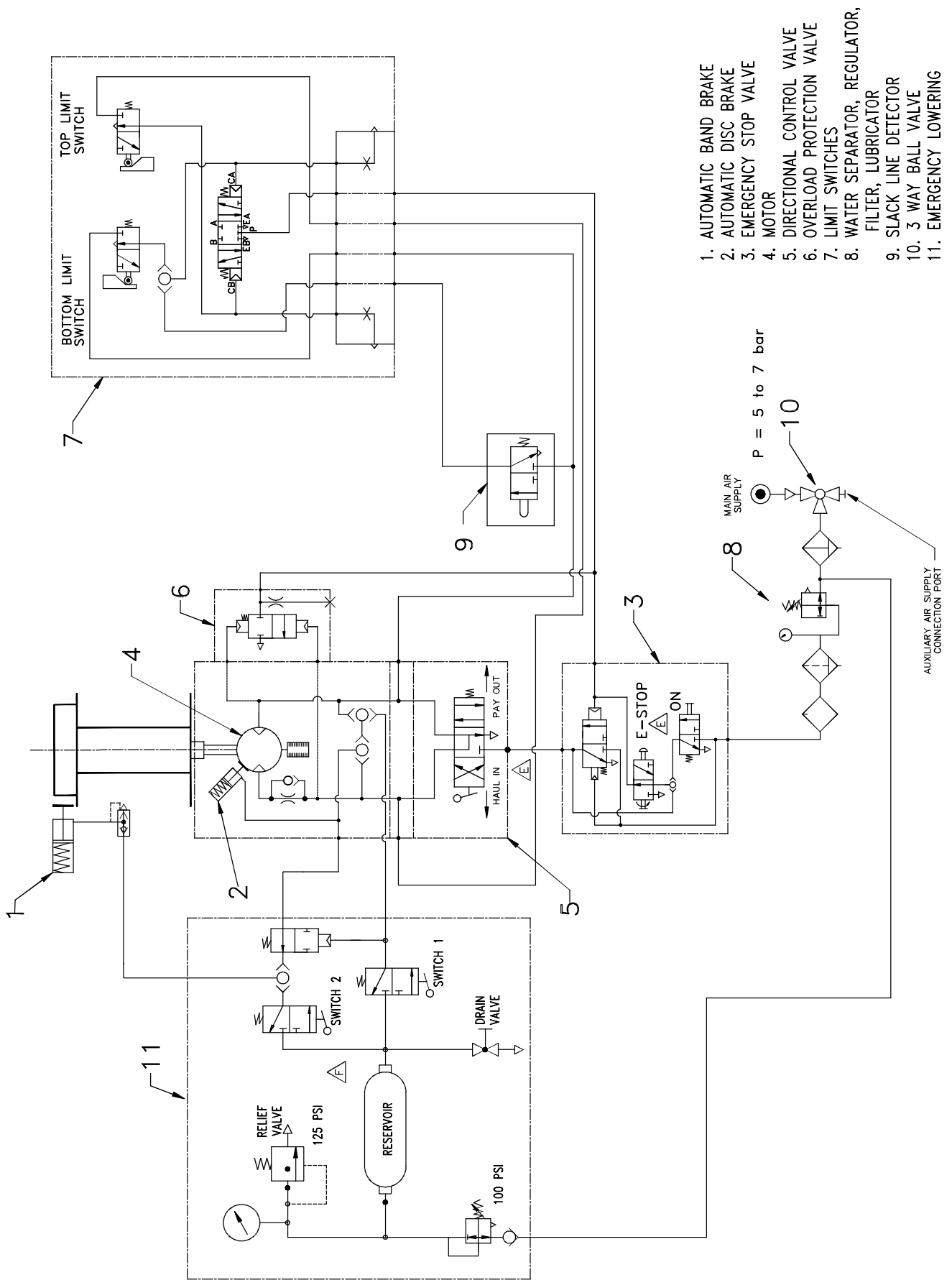

Figure 13. MHP3420



# Air Schematics (For MK2 before 11/19/2021)



# Air Schematics (For MK3 after 11/19/2021)

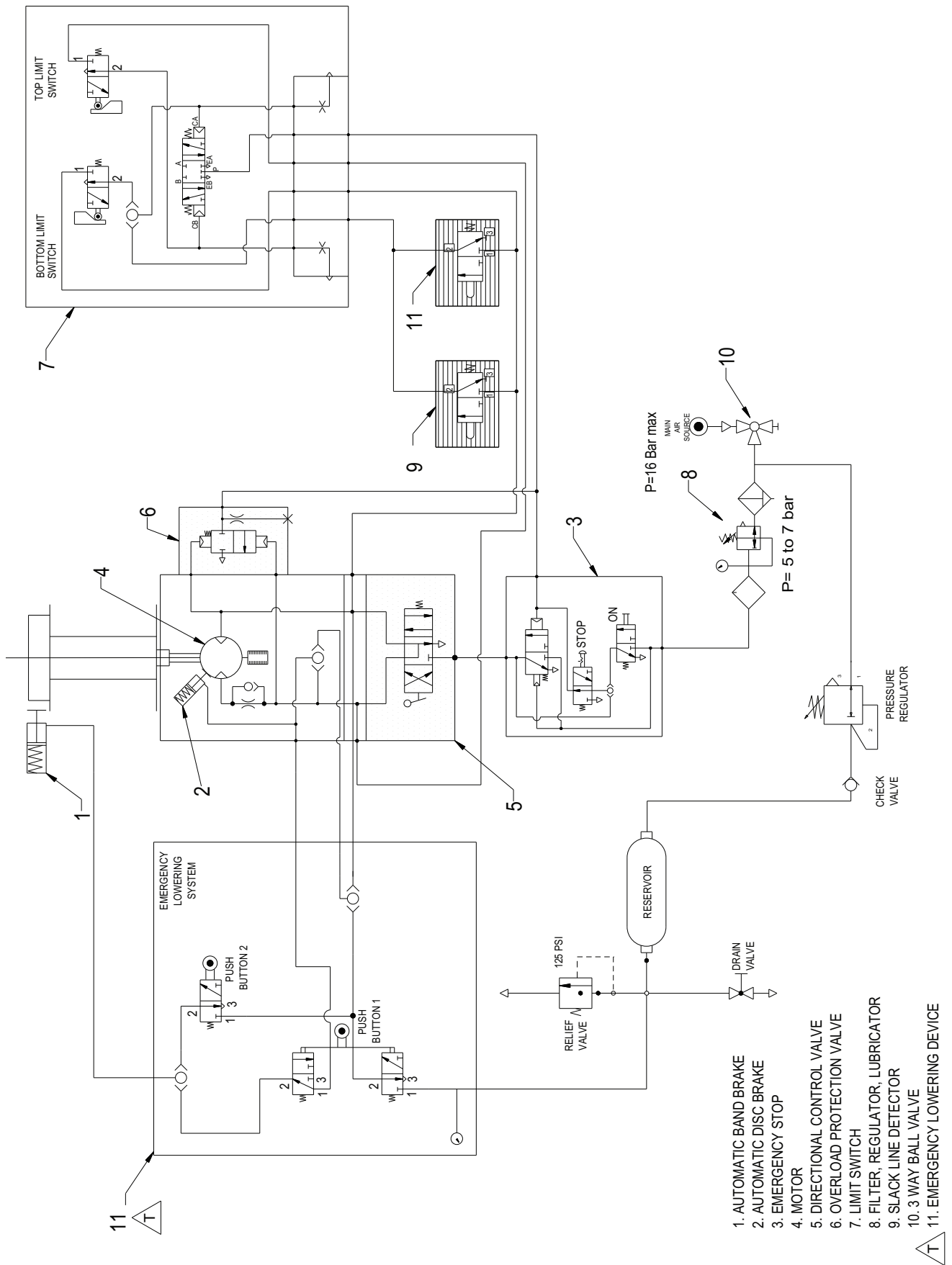

1. AUTOMATIC BAND BRAKE
2. AUTOMATIC DISC BRAKE
3. EMERGENCY STOP
4. MOTOR
5. DIRECTIONAL CONTROL VALVE
6. OVERLOAD PROTECTION VALVE
7. LIMIT SWITCH
8. FILTER, REGULATOR, LUBRICATOR
9. SLACK LINE DETECTOR
10. 3 WAY BALL VALVE
11. EMERGENCY LOWERING DEVICE

# Torque Chart

Standard Coarse Thread Torque						
Size	SAE Grade 5			SAE Grade 8		
	Dry	Lubricated	PTFE	Dry	Lubricated	PTFE
1/4-20	8-10	6-7	4	12-14	9-10	5-6
5/16-18	17-20	13-15	8-9	25-28	18-21	11-13
3/8-16	31-35	23-26	14-16	44-49	33-37	20-22
7/16-14	49-56	37-42	22-25	70-79	52-59	31-36
1/2-13	75-85	57-64	34-38	106-121	80-90	48-54
9/16-12	109-123	82-92	49-55	154-174	115-130	69-78
5/8-11	150-170	113-128	68-77	212-240	159-180	95-108
3/4-10	267-302	200-227	120-136	376-426	282-320	169-192
7/8-9	429-487	322-365	193-219	606-687	455-515	273-309
1-8	644-729	483-547	290-328	909-1030	681-772	409-463
1 1/8-7	794-900	596-675	357-405	1288-1460	966-1095	580-657
1 1/4-7	1121-1270	840-952	504-571	1817-2059	1363-1545	818-927
Standard Fine Thread Torque						
Size	SAE Grade 5			SAE Grade 8		
	Dry	Lubricated	PTFE	Dry	Lubricated	PTFE
1/4-20	10-11	7-8	4-5	14-15	10-12	6-7
5/16-24	19-22	14-16	9-10	27-31	20-23	12-14
3/8-24	35-40	26-30	16-18	49-56	37-42	22-25
7/16-20	55-63	41-47	25-28	78-88	58-66	35-40
1/2-20	85-96	64-72	38-43	120-136	90-102	54-61
9/16-18	121-137	91-103	55-62	171-194	128-146	77-87
5/8-18	170-193	127-144	76-87	240-272	180-204	108-122
3/4-16	297-337	223-253	134-152	420-476	315-357	189-214
7/8-14	474-537	355-403	213-242	669-758	502-568	301-341
1-12	704-798	528-599	317-359	995-1127	746-845	448-507
1 1/8-12	1023-1159	767-869	460-572	1444-1637	1083-1227	650-736
1 1/4-12	1425-1615	1069-1211	641-727	2012-2280	1509-1710	905-1026
Metric Coarse Thread Torque						
Size	Class 8.8 / 9.8			Class 10.9		
	Dry	Lubricated	PTFE	Dry	Lubricated	PTFE
M6x1	9-10	6-7	4	11-12	8-9	5-6
M8x1.25	21-23	16-18	9-11	26-30	20-22	12-13
M10x1.5	41-47	31-35	19-21	53-60	39-45	24-27
M12x1.75	71-81	54-61	32-36	91-103	68-77	41-46
M14x2	115-130	86-98	52-59	147-166	110-125	66-75
M16x2	165-187	124-140	74-84	227-257	170-193	102-116
M20x2.5	321-364	241-273	144-164	443-502	332-376	199-226
M22x2.5	439-497	329-373	197-224	605-686	454-514	272-309
M24x3	556-630	417-473	250-284	767-869	575-652	345-391
M30x3.5	1103-1250	827-938	496-563	1521-1724	1141-1293	685-776

## Torque Chart

Metric Fine Thread Torque						
Size	Class 8.8 / 9.8			Class 10.9		
	Dry	Lubricated	PTFE	Dry	Lubricated	PTFE
M8x1	22-25	17-19	10-11	28-32	21-24	13-14
M10x1.25	44-49	33-37	20-22	56-63	42-47	25-28
M12x1.25	78-89	59-67	35-40	100-113	75-85	45-51
M14x1.5	125-141	93-106	56-64	159-180	119-135	72-81
M16x1.5	176-200	132-150	79-90	243-276	183-207	110-124
M18x1.5	257-291	193-219	116-131	355-402	266-302	160-181
M20x1.5	358-406	268-304	161-183	494-559	370-420	222-252
M22x1.5	484-548	363-411	218-247	667-756	500-567	300-340
M24x2	609-690	456-517	274-310	839-951	630-713	378-428
M30x2	1227-1390	920-1043	552-626	1692-1918	1269-1438	761-863

**Notes:**

- Definitions:
  - DRY:** Cadmium plate, zinc plate, and oiled fasteners.
  - LUBRICATED:** Moly sulfide paste, carnaba wax, moly sulfide grease and copper-based anti-seize coated fasteners.
  - PTFE:** 2% minimum PTFE (teflon) coated fasteners.
- All torque values foot-pounds unless noted.
- SAE grade 5 equivalent to ASTM A325 Type 2 and ASTM A449.
- SAE grade 8 equivalent to ASTM A354 Grade BD, ASTM A490 Type 1.
- If mixing fasteners use lowest torque value.
- Torque values 75 to 85% of fastener proof load ref.

# Warranty

## Ingersoll Rand Limited Warranty

**Ingersoll Rand Company ("IR")** warrants to the original user its material handling products ("Products") to be free of defects in material and workmanship for a period of one year from the date of purchase. **IR** will, at its option either (1) repair, without cost, any Product found to be defective, including parts and labor charges, or (2) replace such Products or refund the purchase price, less a reasonable allowance for depreciation, in exchange for the Product. Repairs or replacements are warranted for the remainder of the original warranty.

If any Product proves defective within its original one-year warranty period, it should be returned to any Authorized Product Service Distributor, transportation prepaid with proof of purchase or warranty card. This warranty does not apply to Products which **IR** has determined to have been misused or abused, improperly maintained by the user, or where the malfunction or defect can be attributed to the use of non-genuine **IR** repair parts.

**IR MAKES NO OTHER WARRANTY, CONDITION OR REPRESENTATION OF ANY KIND WHATSOEVER, EXPRESSED OR IMPLIED, STATUTORY OR OTHERWISE, AND ALL IMPLIED WARRANTIES AND CONDITIONS RELATING TO MERCHANTABILITY AND FITNESS FOR A PARTICULAR PURPOSE, ARE HEREBY DISCLAIMED.**

**IR's** maximum liability is limited to the purchase price of the Product and in no event shall **IR** be liable for any consequential, indirect incidental or special damages of any nature arising from the sale or use of the Product, whether in contract, tort or otherwise.

**Note:** *Some states do not allow limitations on incidental or consequential damages, so that the above limitations may not apply to you. This warranty gives you specific legal rights and you may also have other rights which may vary from state to state.*

Fulcrum series electric winch, product code 405-002: 2 year warranty.

Winch and Hoist Solutions Extended Warranty This option provides a price for extending the **Ingersoll Rand** Winch and Hoist Solutions Warranty from the standard one (1) year to two (2) years from the date of purchase. All other provisions of the standard warranty to remain in effect.

For additional information or quotations for warranties falling outside of these parameters, please contact your Client Services Representative with your requirements.



