



I.R.E.P. S.A.S
59450 Sin le Noble - France
Tél : +33 (0) 27 93 08 08
Fax : +33 (0) 27 93 08 00

Copyright © 2011 Ingersoll-Rand Company
All Rights Reserved

MANRIDER WINCHES
LS2-150HMR-RCB
DATA SHEET FOR COMMON USE
LIFTING WINCH 150KG CAPACITY

IREP Drawing Number	Rev.
477897011	C
Customer Drawing Number	
A. FLIPO	1 / 1
Engineering Manager Approval	

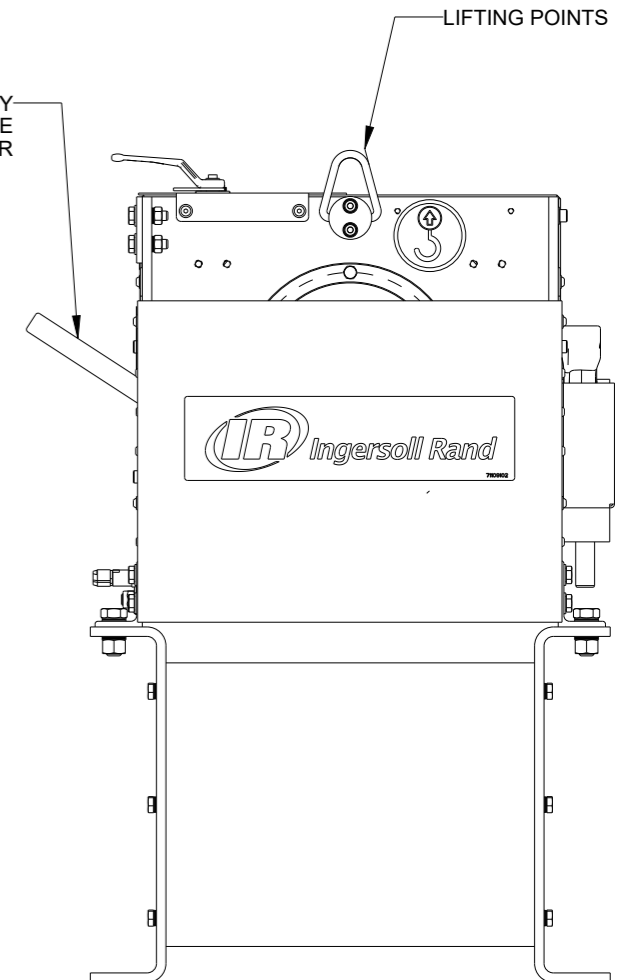
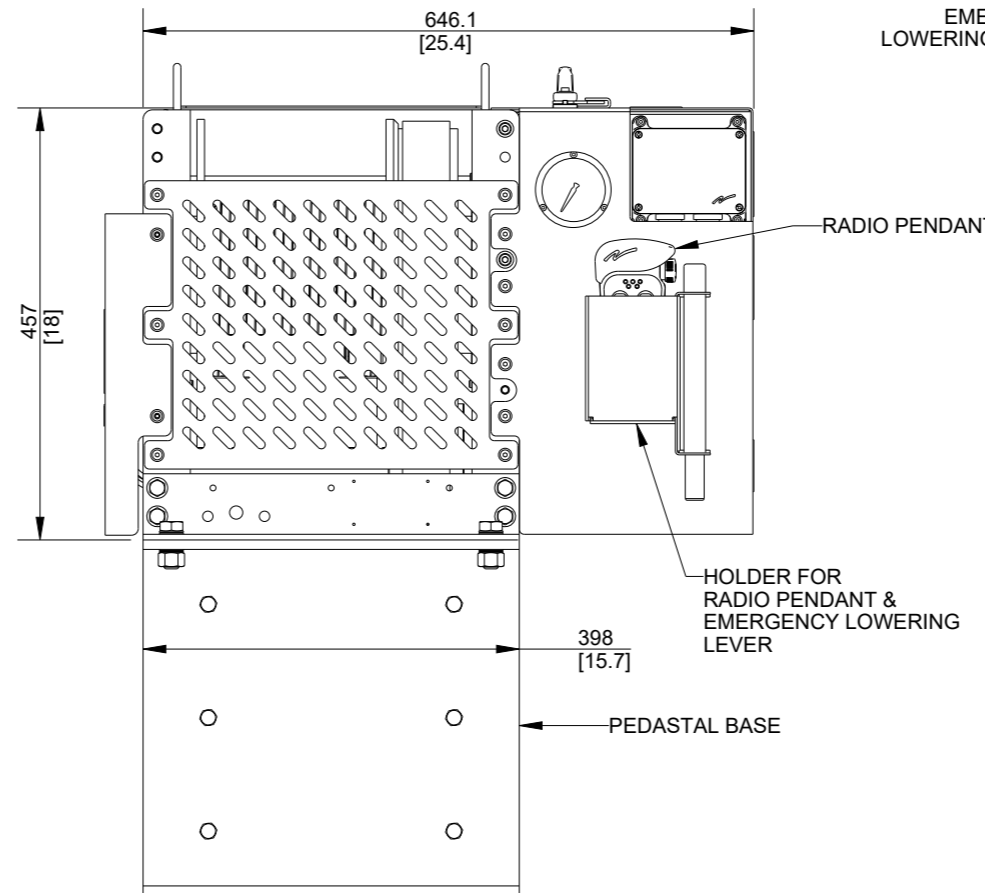
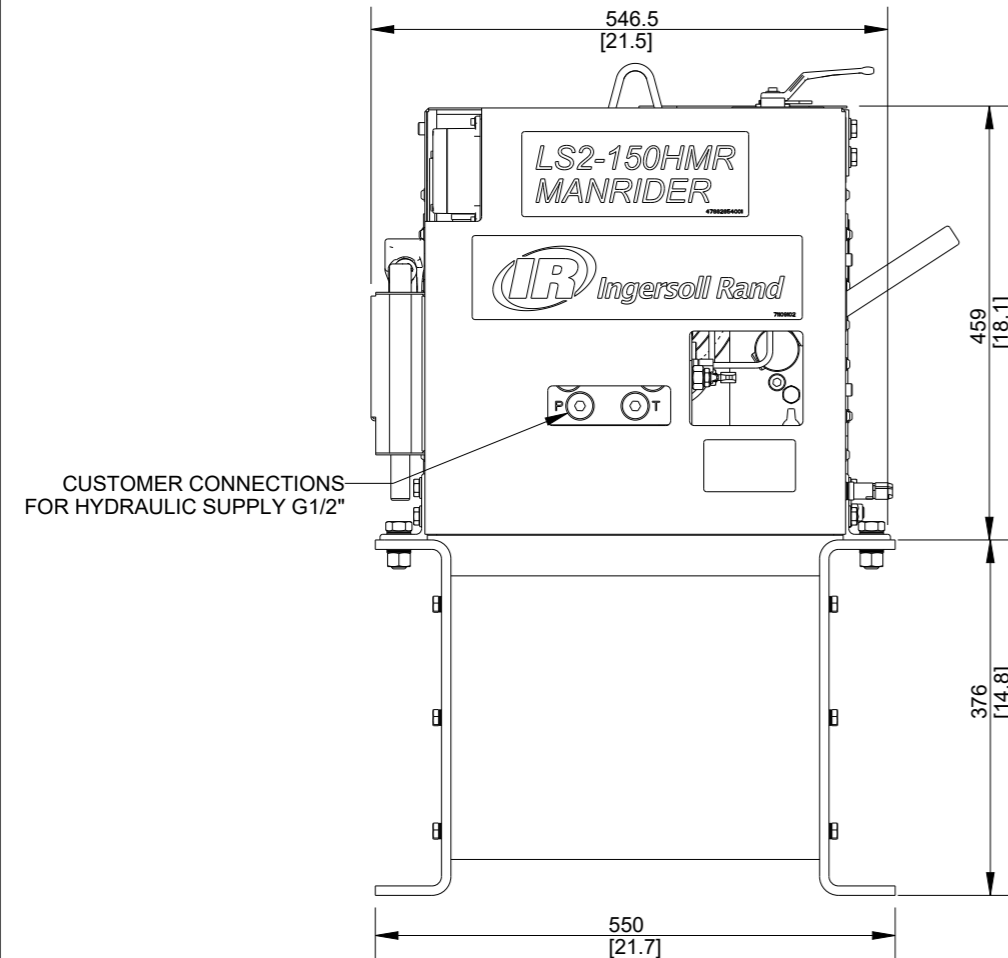

STANDARD FEATURES:

- Compact design. All steel/cast iron construction insensitive to dust and humidity.
- Design factor 10:1 on primary load bearing components.
- Group Mechanism : FEM 1Bm (ISO M3)
- Minimum 24:1 drum diameter to wire rope diameter ratio reduces wire rope wear.
- Design Temperature: -20° C to +60° C
- Radio Control with wireless pendant for haul-in and pay-out.
- Lifting lugs designated for lifting weight of winch plus full drum of wire rope.
- Powerful orbital hydraulic motor providing high torque.
- Upper and Lower rotary electric limit switches.
- Automatic fail safe disc brake (no adjustment required).
- Automatic fail safe drum brake (no adjustment required).
- High efficiency planetary gear box in-drum design.
- Press roller (assisting spooling device).
- Grooved Drum for Wire Rope.
- Overload protection.
- Vertical rope entry (underwound configuration).
- Pre-equipped manual emergency lowering device.
- Stainless Steel Hoses.
- Main Emergency Stop button on the pendant.
- Winch Guards.
- Standard IR paint.
- Pedastal Base - option B.
- Individually load test before shipment and delivered with manufacturer's test certificate for quality assurance.

OPTIONAL FEATURES:

- Material Traceability - option M (3.1 certificates per EN10204).
- Sandblasting and 3 layers of offshore paint system according to ISO C5-m - option QZ.

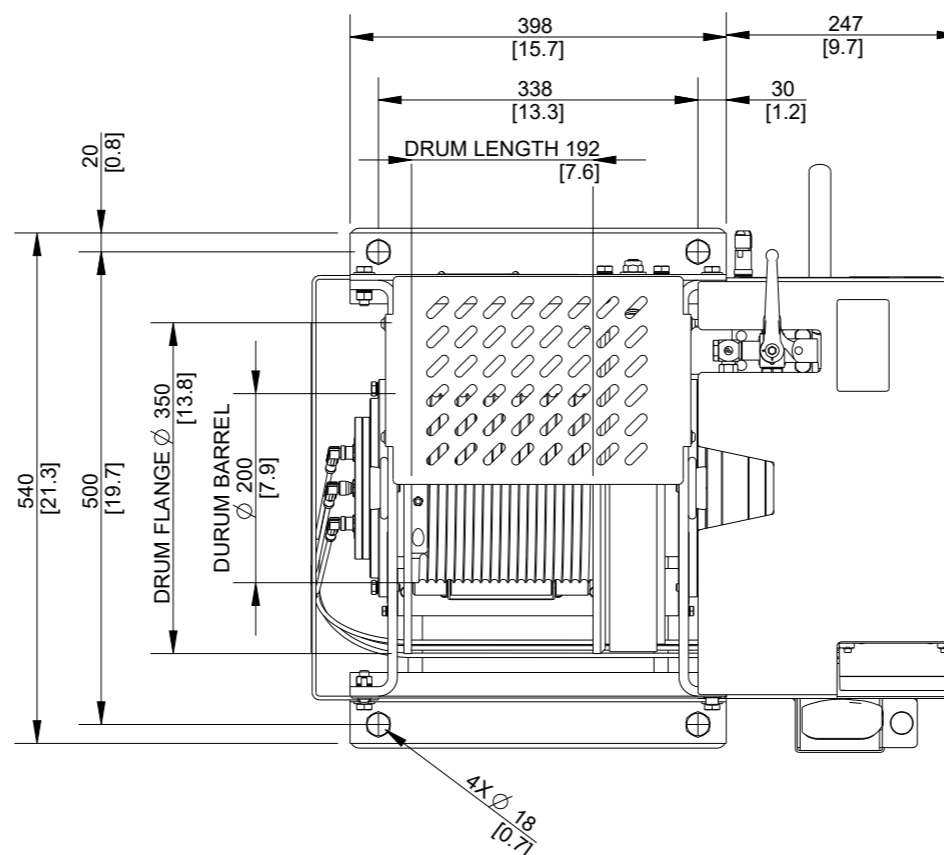

PERFORMANCE SPECIFICATIONS	
RATED LAOD CAPACITY, LBS [KG]	330 [150]
RATED LAYER	4th
RATED LINE SPEED, FT/MIN [M/MIN]	35 [10.5]
WORKING CAPACITY, FT [M]	394 [120]
TOTAL DRUM CAPACITY, FT [M]	557 [170]
WIRE ROPE SIZE, IN [MM]	5/16" [8]
INLET PRESSURE FOR RATED LAOD, PSI [BAR]	725 [50]
INLET FLOW FOR RATED LAOD, GPM [L/MIN]	2.65 [10]
WEIGHT WITHOUT WIRE ROPE, LBS [KG]	375 [170]
INPUT POWER SUPPLY	24VDC

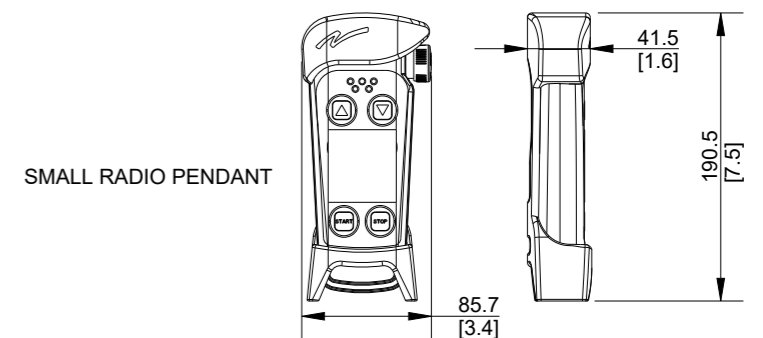

ALL THE DRAWING VIEWS ARE REPRESENTED IN FIRST ANGLE ORIENTATION

Built using nearly a century of experience and constructed in advanced manufacturing facilities with ISO 9001 quality levels