

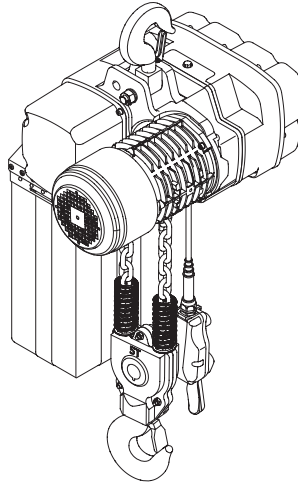

Electric Chain Hoist

EVLK Series: 1/2 to 5 ton



Product Information



Save These Instructions

Only allow **Ingersoll Rand** trained technicians to perform maintenance on this product. For additional information contact **Ingersoll Rand** factory or nearest distributor.

Manuals can be downloaded from irtools.com/manuals

The use of other than genuine **Ingersoll Rand** replacement parts may result in safety hazards, decreased performance and increased maintenance and will invalidate all warranties.

Original instructions are in English. Other languages are a translation of the original instructions.

Refer all communications to the nearest **Ingersoll Rand** office or distributor.

Product Description

These EVLK Series Electric Chain Hoists are electric powered and designed to lift and lower loads. These hoists are not designed to lift, support or transport people. They can be installed as a stationary or mobile unit.

General Operating Conditions

Working Temperature Range		-5 °C to 40 °C (23 °F to 104 °F)
Working Humidity Range		85% or Less
Protection	Hoist	IP55
	Push Button Switch	IP65
Electric Power Supply		200 - 480 V / 3Ph / 50 - 60 Hz and 575 V / 3Ph / 60Hz
Noise Level		75 dB

Mechanical Classification (Grade) and Life

Safety and life of electric chain hoists are guaranteed only when the equipment is operated in accordance with the prescribed grade.

Electric chain hoists have been designed for grade 2 m in the FEM Regulations (FEM 9.5.11). Details are provided in Table 1. Average daily operating time and total operating time are determined by load distribution.

Table 1: Mechanical classification

Load Spectrum (Load distribution)	Definitions	Cubic Mean Value	Average Daily Operation Time (h)	Total Operating Time (h)
1 (Light)	Mechanisms or parts thereof, usually subject to very small loads and in exceptional cases only to maximum loads.	$K \leq 0.50$	4 - 8	12,500
2 (Medium)	Mechanisms or parts thereof, usually subject to small loads but rather often to maximum loads.	$0.50 < K \leq 0.63$	2 - 4	6,300
3 (Heavy)	Mechanisms or parts thereof, usually subject to medium loads but frequently to maximum loads.	$0.63 < K \leq 0.80$	1 - 2	3,200
4 (Very Heavy)	Mechanisms or parts thereof, usually subject to maximum or almost maximum loads.	$0.80 < K \leq 1.00$	0.5 - 1	1,600

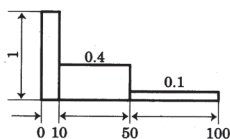

% Operating Time
Load Spectrum 1

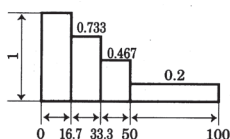

% Operating Time
Load Spectrum 2

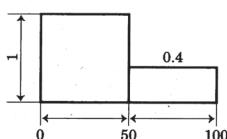

% Operating Time
Load Spectrum 3

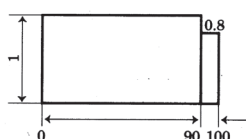

% Operating Time
Load Spectrum 4

CAUTION

The trolley must have a lifting capacity that is equal to or greater than the electric chain hoist.

NOTICE

Refer to the Product Parts Information Manual for all component and part details.

Housing

The housing and cover are made of durable cast aluminum, and the motor area includes cooling fins for efficient heat dissipation. The chain container can be mounted directly to the compact housing. Holes are provided for securing the power supply and control cables. The hook suspension is attached to the top flange.

Motor and Brake

EVLK electric chain hoists are driven by PMSM (Permanent Magnet Synchronous Motor). Models are available in VFD (Variable Frequency Drive). The motors are specifically designed for hoist duty requirements and are rated for lifting operations. The "Electro-Magnetic Brake" unique design, it features simultaneous motor braking upon switching off power even under full load condition, quick action and high frequency use.

Mechanical Brake with Clutch and Overload Protection Device

The unique design includes mechanical brake & overload dual protection. Mechanical clutch operates with motor brake, which can offer exactly, very limited slipping & quick braking. OL device prevents over loading to damage goods, and ensure secure operation and product's life-span.

Limit Switch

A limit switch is installed to control the highest and lowest chain positions. Upper and lower limit switches are fitted for switching off power automatically in case of over lifting or over lowering.

Electrical Controller

The electric chain hoists are equipped with a 24 V and 110 V pendant controller as standard. The emergency stop contactor disconnects all three main power legs from the power source when the Emergency-Stop button is pressed.

Chaindrive

The hoist is equipped with a 5 pocket liftwheel and uses case carburized highly heat treated load chain for long life. Chain guides are easily removed for inspection. All hooks are equipped with a safety latch.

Gearbox

The three stage gearing is designed for lifting gear requirements. The gear wheels are mounted on roller bearings and have continuous lubrication. The helical gearing reduces running noise to a minimum.

Control Switch

The standard equipment of the electric chain hoist includes a control switch for lifting and lowering with an emergency stop. When the emergency stop is activated, its automatic disconnect contact opens the power circuit that supplies the contactors. For additional travel directions, a 4-button control switch is provided with the motorized trolley.

Motorized Trolley

The motorized trolleys are designed for use with the Electric Chain Hoists. The trolleys are available in the following capacities: 0.5 ton - 5 ton, these trolleys are similar except for the size of the load carrying members.

The trolleys have rugged steel side plates with anti-drop fins, steel wheel axles, steel suspension bolts, construction steel load plate seated in middle of two suspension bolts for top hook of hoist to hook on. The hot forged travelling wheels machine to suit both I-beam and flat beam. Hardened steel gears are attached to two trackwheels and driven by a hardened steel pinion. The pinion is driven by planetary gear reducer in high quality grease. A weather proof motor drive the gear reducer.

The electric housing contains a reversing contactor and terminal boards. A transformer is optional depending on the user's needs. The 3-phase motor is always equipped with a magnetic brake at the end of the driven motor. There are three holes above the bottom of the housing: one for the hoist cord, one for the hoist control cord and one for the trolley motor cord. The third hole can be used for the Push-Bottom-Station cord for the trolley. In addition, there are two optional holes on each side of the housing: one for the motor power cord on the right and one for the trolley power cord on the left. All five holes can be equipped with a cable gland for IP55 protection.

Model Code Explanation:

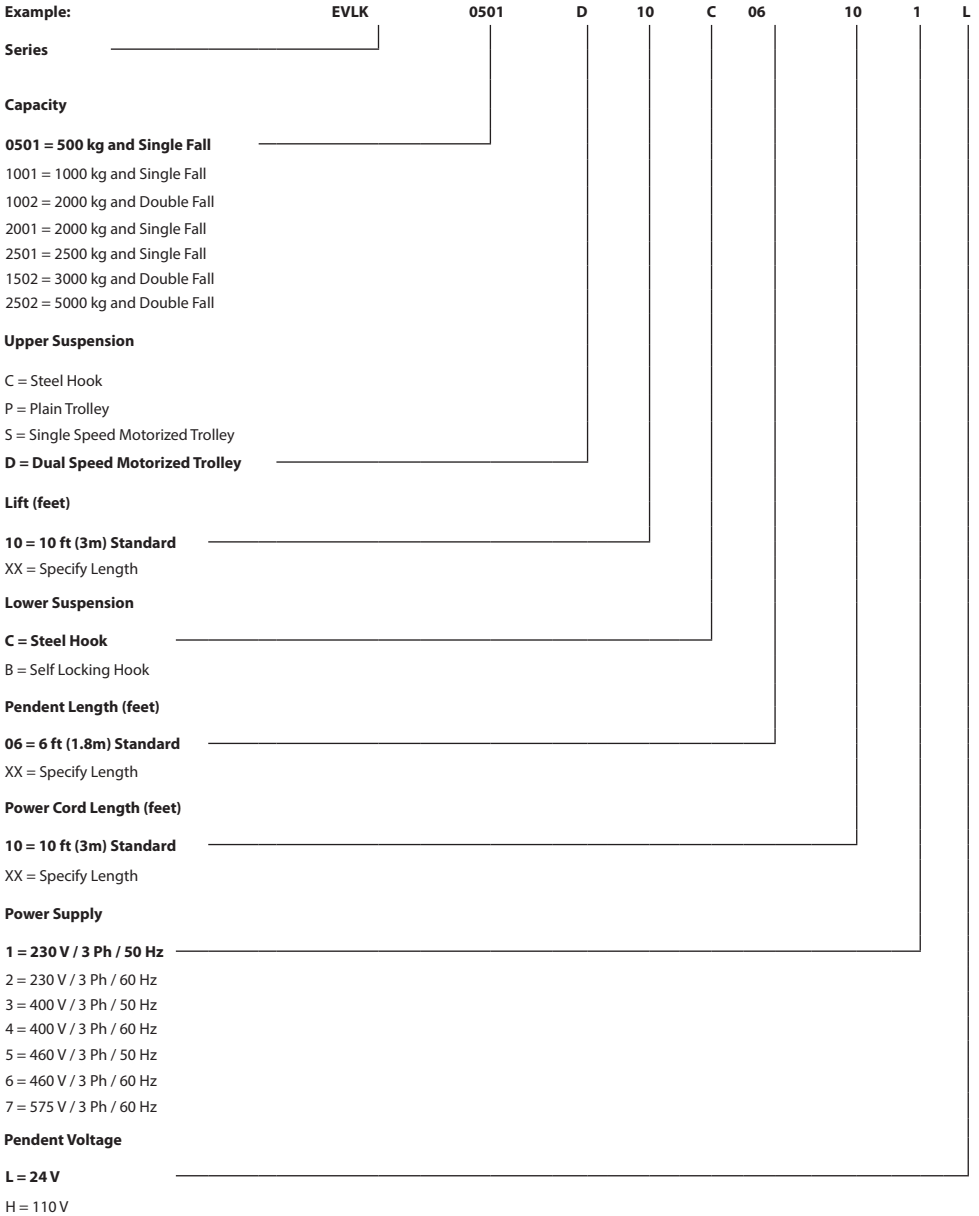

Hoist Specification and Dimensions

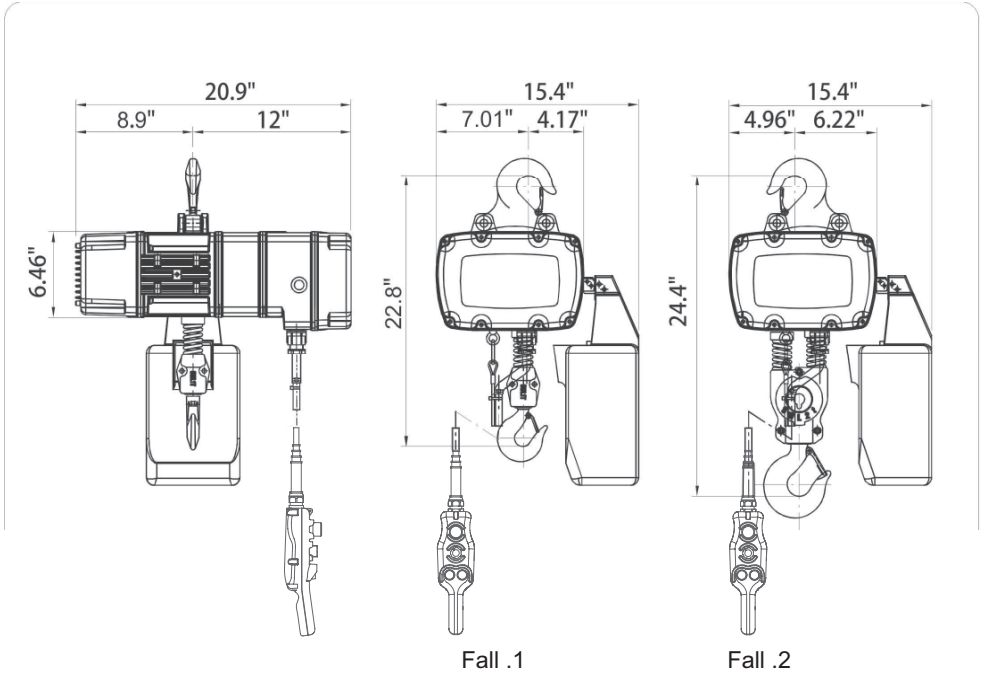

Fall .1

Fall .2

Table 2: Rated Source: 200 - 480 V / 3Ph / 50 - 60 Hz and 575 V / 3Ph / 60Hz

Models	Capacity (lbs)	Motor Output (HP)	Intermittent Duty		Rated Current (A)	Lifting Speed (ft/min)		Standard Lift (ft)	Load Chain Diameter (mm)	Fall	N.W. (lbs)
			% ED	Max. Starting Frequency (times/hour)		Low	High				
EVLK0501	1,100	1.5	40	240	200 V (5.3 A) - 575 V (2.2 A)	6.6 - 17	33	10	6.3 x 19.1	1	94
EVLK1001	2,200	2.0			200 V (7.3 A) - 575 V (3.2 A)	5.2 - 14	26		7.1 x 20.2	1	102
EVLK1002	4,400				2.6 - 6.9	13	2			110	

Hoist Specification and Dimensions

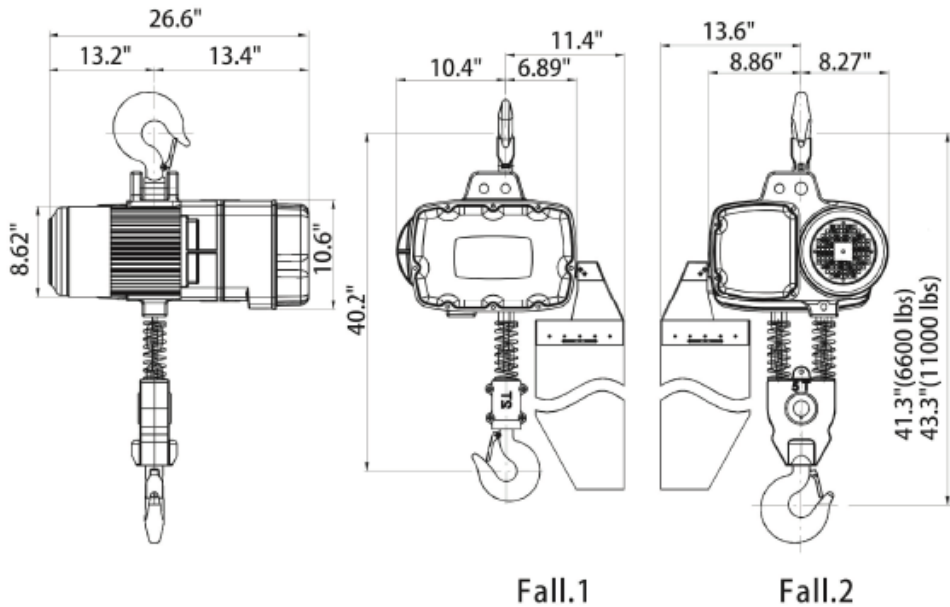

Table 3: Rated Source: 200 - 480 V / 3Ph / 50 - 60 Hz and 575 V / 3Ph / 60Hz

Models	Capacity (lbs)	Motor Output (HP)	Intermittent Duty		Rated Current (A)	Lifting Speed (ft/min)		Standard Lift (ft)	Load Chain Diameter (mm)	Fall	N.W. (lbs)
			% ED	Max. Starting Frequency (times/hour)		Low	High				
EVLK2001	4,400	5	40	240	200 V (16.3 A) - 575 V (5.7 A)	6.2 - 12	31	10	10 x 30	1	209
EVLK2501	5,500					5.2 - 10	26		11.2 x 34	1	224
EVLK1502	6,600					4.3 - 8.5	21		10 x 30	2	246
EVLK2502	11,000					2.6 - 5.2	13		11.2 x 34	2	297

Motorized Trolley Specification and Dimensions

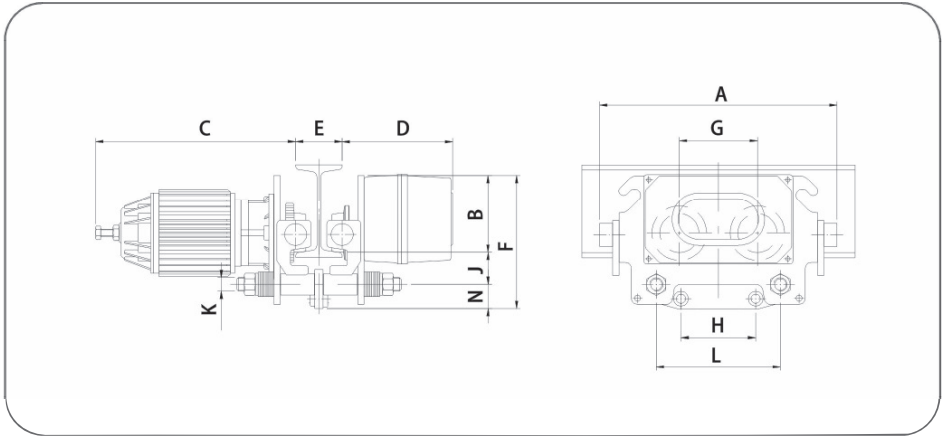

Table 4: Motorized Trolley Specification and Dimensions

Models	Speed (ft/min)		Motor (HP) x Pole	Dimensions (in.)											N.W. (lbs)	Min. radius of Curve (ft)	
	60 Hz	50 Hz		A	B	C	D	E	F	G	H	L	J	N			K
MT-050-S1	79	66	0.16 x 2P	15.2	5	12.8	7.09	2.95	8.58	4.96	4.72	7.87	2.05	1.54	7 / 8"	99	4.3
MT-050-D1	79/20	66/17	0.16 / 0.04 x 2 / 8P					-							4.92		
MT-100-S1	79	66	0.24 x 2P	15.2	4.49	12.8	7.09	2.95	8.66	4.96	4.72	8.27	2.64	1.54	1"	99	4.3
MT-100-D1	79/20	66/17	0.24 / 0.06 x 2 / 8P					-							4.92		
MT-200-S2	79	66	0.5 x 2P	15.6	4.72	14.2	7.28	3.94	9.09	6.26	4.72	9.06	2.95	1.42	1 1 / 4"	110	5.6
MT-200-D2	79/20	66/17	0.5 / 0.13 x 2 / 8P					-							5.91		
MT-200-S1	79	66	0.5 x 2P	15.6	4.92	14.2	7.28	3.94	9.88	6.26	2.07	9.06	2.95	2.01	1 1 / 4"	110	5.6
MT-200-D1	79/20	66/17	0.5 / 0.13 x 2 / 8P					-							5.91		
MT-250-S1	79	66	0.8 x 2P	17.5	6.06	15.7	7.68	4.92	11.1	7.2	2.07	9.84	2.8	2.28	1 1 / 2"	196	6.6
MT-250-D1	79/20	66/17	0.8 / 0.2 x 2 / 8P					-							6.89		
MT-300-S2	79	66	0.8 x 2P	17.5	6.06	15.7	7.68	4.92	11.1	7.2	2.07	9.84	2.8	2.28	1 1 / 2"	196	6.6
MT-300-D2	79/20	66/17	0.8 / 0.2 x 2 / 8P					-							6.89		
MT-500-S2	79	66	0.8 x 2P	17.5	6.06	15.7	7.68	4.92	11.1	7.2	2.07	9.84	2.8	2.28	1 3 / 4"	196	6.6
MT-500-D2	79/20	66/17	0.8 / 0.2 x 2 / 8P					-							6.89		

Plain Trolley Specification and Dimensions

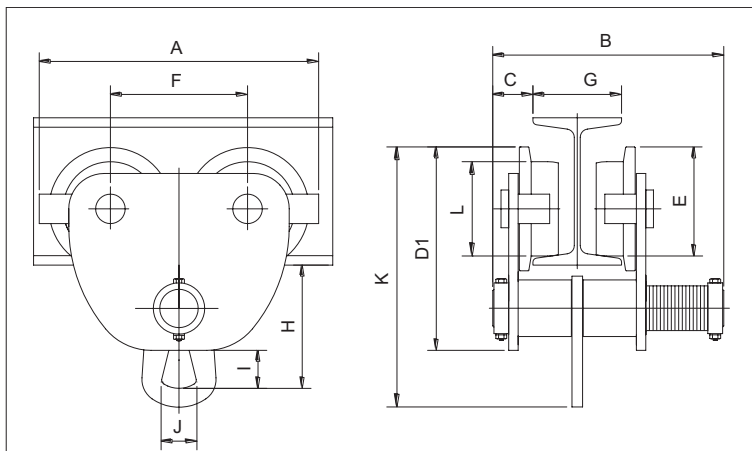

Table 5: Plain Trolley Specification and Dimensions

Models	Rated Capacity (t)	Test Load (t)	Min. radius of Curve (m)	H-beam recommended (G) (mm)	Dimensions (mm)											Net Weight (kg)
					A	B	C	D1	E	F	H	I	J	K	L	
PT-050	0.5	0.63	1	50 - 150	194	220	35	151	69	89	115	33	28	198	60	6.4
PT-100	1	1.25	1	75 - 150	217	227	39	167	78	100	124	35	31	218	70	10.6
PT-200	2	2.5	1.3	100 - 175	247	260	43	204	91	116	171	55	56	284	80	16.8
PT-300	3	3.75	1.5	100 - 200	270	300	50	239	103	130	215	79	60	353	90	25.8
PT-500	5	6.3	1.6	125 - 200	310	304	52	251	117	140	218	84		370	100	32.6

Operational Parameters

Electric chain hoists are manufactured according to the latest technical developments, safety regulations, and specifications. They are also tested for safety by the manufacturer. The operational parameters of electric chain hoists encompass compliance with safe operating practices, as well as maintenance and parts manuals.

The operational parameters do not include the following:

- **Exceeding the defined load capacity,**
- **Diagonal pulling of the load or yarding,**
- **Excessive impact or lifting of guided loads.**

Avoid excessive inching operations, ground mooring, and running against limit switches.

The operating temperature range is from -5 °C to 40 °C (23 °F to 104 °F).

In accordance with ASME HST-1-2012, hoists are rated at H4 duty class.

The manufacturer is not responsible for any damage to this equipment resulting from abnormal operating practices.

Start - Up

⚠ DANGER

Mechanical adjustments should be performed by authorized designated personnel.

⚠ CAUTION

Before operating the electric chain hoist for the first time, the operators must carefully read the operating instructions and carry out all necessary checks. The device may only be put into operation once safe operation has been established. Unauthorized persons may not operate the device or perform any work with its assistance.

Transport and Assembly

DANGER

- **This hoist is not intended for, and must not be used for, lifting, supporting, or transporting personnel. Any modifications intended to upgrade, re-rate, or otherwise alter the hoist must be performed only with authorization from the original manufacturer or a qualified personnel.**
- **Do not use the hoist in explosive atmosphere.**

The safety directions for handling loads must be followed when transporting and assembling electric chain hoists. Refer to the Product Safety Information Manual for more information.

Electric chain hoists must be assembled by qualified personnel who always bear in mind the accident prevention directions. The electric chain hoist must be stored in an enclosed room or covered area before assembly. If the electric chain hoist is going to be used outdoors, it is recommended that a protection roof be erected to shield it from the weather.

The electric chain hoist should be transported in its original packaging whenever possible. It is recommended that qualified personnel conduct the assembly and connection of the hoist on-site.

Installation

Unpacking Information - Hoist

After removing the hoist from its packaging, carefully inspect the exterior of the electrical cables, contactor, gearbox, and motor casing for damage. Ensure that all of these items are present. Each hoist is supplied with the following accessories as standard.

Table 6: Hoist Components

Chain Bucket	1 Piece
Power Cable	10 ft
Separated Control Cable with PBS and Male Plug	1 Set

Unpacking Information - Motorized Trolley

After removing the trolley from the shipping carton or crate, carefully inspect the external condition of the cord, electric housing, gear reducer, motor, and brake (for 3-phase models only) for damage that may have occurred during shipment or handling. Ensure that all parts are present, including the trolley side frame with electric housing, the side frame with reducing gear motor, the position tube, the spacer washer, the stay bolts, the nuts, and the load plate for the hoist top hook. Before attempting to install the trolley, also make sure that the power supply indicated on the labels attached to the motor housing matches the power supply on which the unit will operate.

In general, the hoist and trolley are packed separately. However, if the order indicates a requirement for four-way control of the hoist with the trolley, then the hoist and trolley will be packed together in one wooden crate.

Before installing the hoist, carefully inspect the components for any damage that may have occurred during shipping.

Hoists are supplied fully lubricated from the factory. Refer to the "Lubrication" section on page EN-16 for recommended oils and lubrication intervals. It is recommended that the load chain be lubricated before the initial operation of the hoist.

WARNING

- **Falling loads can cause injury or death. Read the Product Safety Information Manual before installing.**
- **Before installing or using this product, owners and users are advised to examine the specific local, state, or federal regulations that may apply to its use, including those of the American National Standards Institute and/or the Occupational Safety and Health Administration (OSHA).**
- **The strength of hoists, chains, and hooks can be affected by exposure to caustic or acidic substances. Consult a qualified person before using hoists in such environments.**

Mounting

Always ensure that the support structure to which the hoist is attached can withstand the combined weight of the hoist, the maximum rated load, and a safety factor. Consult a structural engineer for more information.

If the hoist is suspended by a top hook, the supporting member should rest completely within the saddle of the hook and be centered directly above the hook shank. Do not use a supporting member that tilts the hoist.

Hook Mounted Hoist

Place the hook over the mounting structure. Ensure that the hook latch is engaged.

Trolley Mounted Hoist

When installing a trolley on a beam, first measure the beam flange. Then, temporarily install the trolley on the hoist to determine the exact distribution and arrangement of the spacers. Adjust the spacers according to the manufacturer's instructions to ensure the correct distance between the wheel flange and the beam. In order to keep the hoist centered under the I-beam, the number of spacers between the trolley side plate and the mounting lug on the hoist must be the same in all four locations. Distribute the remaining spacers equally on the outside of the side plates.

Trolley to Beam

It is recommended that you mount the trolley on the beam before attaching the hoist to it. Before mounting the trolley, measure the width of the beam flange on which it will operate. Use this measurement to determine the arrangement of the spacer washers between the two trolley side frames. First, loosely assemble the side frames, position tubes, spacer washers, and nuts on the stay bolts.

Due to variations in beam flange width, measuring the beam flange width is recommended to determine the exact spacer washer distribution. For straight runway beams, the distance between trackwheel flanges should be 3-5 mm greater than the beam flange width. For runway beams that include sharp curves, the distance should be 5-7 mm greater than the beam flange width. Install the trolley on the beam by sliding one side frame out far enough to allow the track wheels to clear the beam flange. Lift the trolley up so that the track wheels are riding on the beam, then draw the side frames together and tighten the nuts snugly.

WARNING

At least one mounting spacer must be used between the head of each trolley bracket bolt and the trolley bracket, as well as between each trolley bolt nut and the trolley bracket. Failure to do so could cause the hoist to fall if used improperly.

Ensure that the trolley bolts or nuts are torqued according to the manufacturer's specifications. When installing the hoist and trolley on a beam, ensure that the side plates are parallel and vertical.

After installation, ensure that the beam stops are in place. Then, operate the trolley over the entire length of the beam while suspending a capacity load 4 to 6 inches (10 to 15 cm) above the floor.

CAUTION

To prevent damage to the trolley from an unbalanced load, the hoist must be centered under the trolley.

NOTICE

The trolley wheels ride on top of the lower flange of the beam.

- Prior to installation check and ensure that the top hook assembly is securely attached to the hoist by means of the lock bolt.

Note: If the hoist is to be installed under a trolley, remove the top hook and install the trolley on the hoist.

- Assemble the chain bucket.

Figure 1. MHP5336

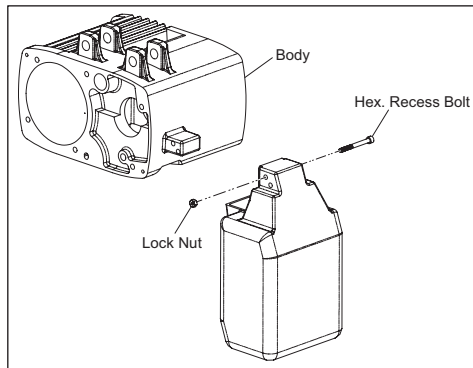
**Power Connection****Voltage****CAUTION**

Abnormal operation or damage to the motor may result if the power supply deviates from the standard by more than $\pm 10\%$. Therefore, it is imperative to ensure the correct voltage supply before commencing operation.

DANGER

Only authorized specialists should perform electrical connection adjustments.

Before connecting the electric chain hoist to the mains power supply, the customer must install the main connection cable, fuse, and switch.

Three-phase models require a four-wire cable with a ground protective conductor to provide the power supply. A three-wire cable with a protective conductor is adequate for single-phase models. The length and gauge must be determined to support the electric chain hoist's power consumption.

DANGER

The ground conductor must not carry any power. In motorized trolley operations, the power supply is enclosed in a terminal box on the drive motor. When installing a motor protector, note the load plate voltage of the electric chain hoist.

CAUTION

Direction of Rotation Check: If the direction of rotation does not align with the symbols on the control switch buttons, the L1 and L2 power supply wires must be switched.

WARNING

If electrical connections are not tight and secure, they can cause a fire. During installation, the electrician must ensure that all connections, including the ground connection, are secure. Ensure that all junction boxes and switch enclosures are adequately sealed and protected from environmental conditions.

NOTICE

Ensure that the wire connection at the terminal is in accordance with Figure 2, MHP5333.

Plug the power supply into the hoist and operate the push-button switch. This operation must be performed by a trained individual.

Figure 2. Power Connection (MHP5333)

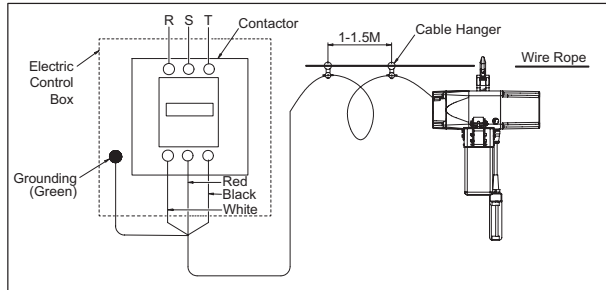

Motorized Trolley Electrical Installation

Refer to Figure 3, MHP5334 on page EN-11.

The electrical connection of the trolley must be completed according to the hoist and trolley general arrangement. Typically, the electrical housing has three holes in the bottom: one for the trolley motor cord, one for the trolley power cord from the hoist, and one for the control cord from the hoist. Additionally, an optional five-hole design is available for independent trolley usage. There are two holes on each side of the housing: one for the trolley power cord and one for the trolley motor cord. For details on wiring connections, please refer to the wiring diagrams. Please note that the above diagrams are only applicable to standard 3-phase units.

The following example illustrates the hoist wiring diagram with trolley:

The model number A20199 is a three-phase, dual-speed model and SF22000145-2101 is a three-phase, single-speed model. For more information, refer to the Hoist with Trolley Wiring Diagram (MHP5335-2) on page EN-12.

For information on the special unit, please refer to the wiring diagram that was supplied with it.

Operation

After running tests and checks have been completed, the hoist will be ready for normal operation.

⚠ WARNING

Heavy loads can present significant hazards; therefore, all applicable safety rules must be strictly followed. The operator must also remain aware of the following points when operating the hoist.

1. After connecting the power supply, allow 15 seconds for the startup process to initiate.
2. Before operating the hoist, the operator must ensure that they have a clear and unobstructed view of the entire work area.
3. Before operating the hoist, the operator must ensure that the entire work area is safe and secure.
4. When using the hoist with a plain trolley, the operator must be careful to prevent the load from swinging excessively by moving the trolley in a way that cancels out the swing.

Operation Test

1. Push the Ⓜ switch button firmly to lower the load chain until the end of the chain touches the limit switch. The power should cut off automatically.
2. Push the Ⓜ switch button firmly to check the load chain collection in the chain bucket.
3. Check the load chain lubrication. Although it was lubricated at our facility, the lubricant may dry out during transportation. It is also advisable to keep a small amount of lubricant in the chain bucket to allow the chain to sit in an oil bath.

Note: We recommend using a lubricating oil equivalent to ISO VG460.

4. Check the emergency stop device: While holding down either button on the push-button switch, press the emergency stop button. Make sure the hook stops when the emergency stop button is pressed. Also, ensure that the hoist does not move in response to the push-button switch. Finally, verify that the emergency stop device pops out when turned to the right, allowing operation to resume. If the equipment fails any of these checks, check the wiring and the emergency stop device's automatic locking function.

Test Running

After the trolley is connected to the beam and the hoist hook is connected to the trolley, as well as the wiring connection is complete, operate the trolley forward and backward over a short distance. Then, operate the trolley over the entire length of the runway or monorail system to ensure all adjustments and operations are satisfactory.

Figure 3. Hoist and Trolley General Arrangement (MHP5334)

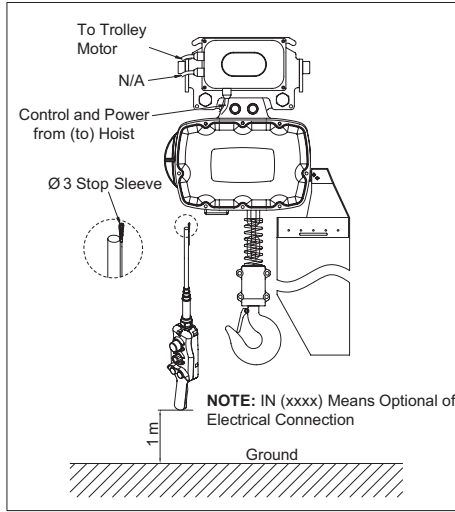

Figure 4. Hoist with Trolley Wiring Diagram (MHP5335-1)

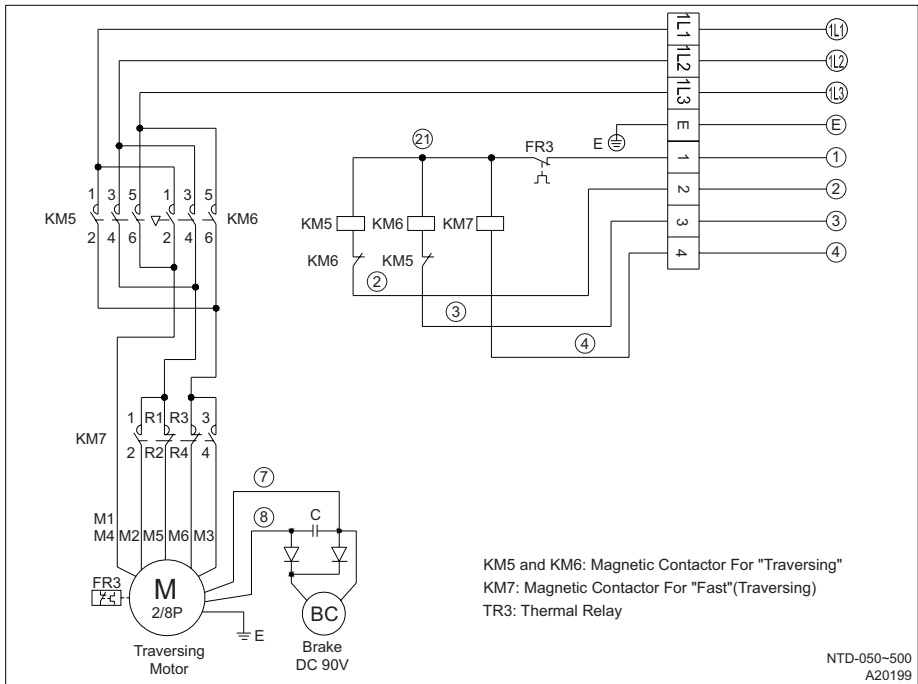
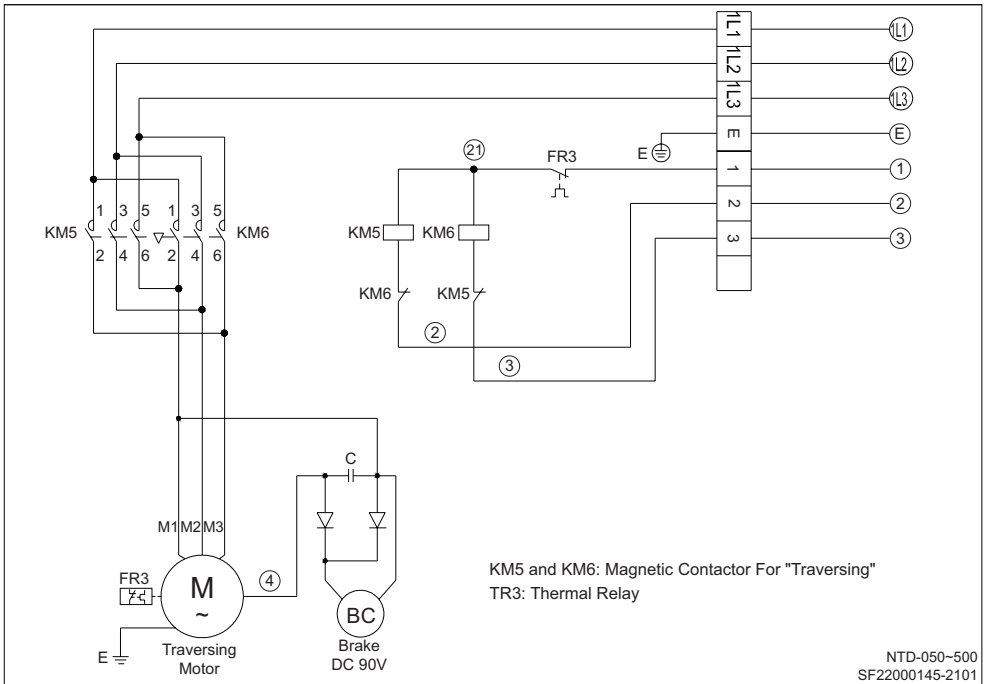

Figure 5. Hoist with Trolley Wiring Diagram (MHP5335-2)



Direction of Movement Check

⚠ CAUTION

The hoist must operate according to the symbols on the control pendant. If the hoist does not operate according to the control pendant symbols, then the hoist is misphased. If so, switch any two of the supply power wires (L1 and L2).

Load Chain

Refer to Figure 6. MHP4157.

⚠ CAUTION

- Only use the original chains supplied by the manufacturer.
- The welded seams of the chain links must face inward on the chain wheel.
- In order to install the geared limit switch in the chain, it must be mechanically disabled. See the section on limit switches for more information.

Figure 6. MHP4157

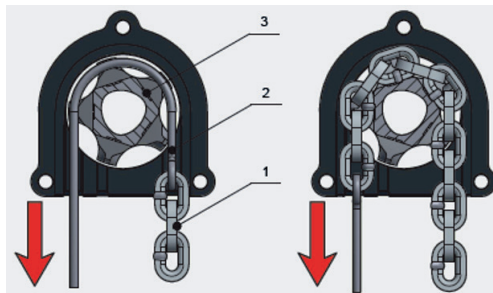

Before starting up and during operation, oil the load chain along its full length. There must be a constant presence of oil on the internal, contacting, and rubbing surfaces of the chain links. Lubricate the chain by submerging it or using an oil can with creeping gear oil. Attach the end of the chain (1) to a flexible wire or chain pulling loop (2), and feed it through the chain wheel (3) of the electric chain hoist. Slowly run the hoist in the lifting direction; the chain will be pulled in correctly. Adjust the lifting height so that the hook fittings are on the ground in the lowest hook position.

Single fall operation

Refer to Figure 7. MHP4158.

The load hook (1) is connected to the chain with a single fall hook clamp (2). Proper mounting of the bolt (3) is important for power transmission.

Figure 7. MHP4158

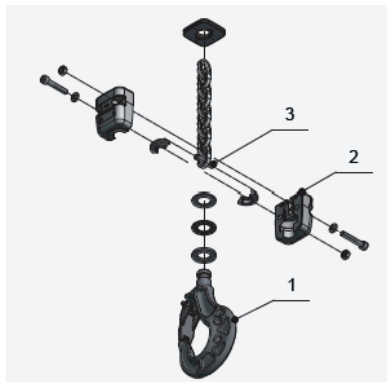

NOTICE

- Make sure that the suspension is arranged correctly.
- Make sure to thoroughly grease the bearings.

Double fall operation

Refer to Figure 8. MHP4159.

Attach the load hook (1) to the double fall hook clamp (2). Secure the chain end to the housing with the supplied bolts (3) and screw (4).

Figure 8. MHP4159

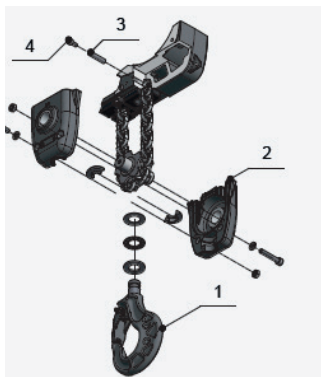

NOTICE

Make sure to arrange the suspension correctly. Ensure that the longitudinal chain is not twisted. Secure one end of the chain to the housing.

Inspection

In order to ensure continuous and satisfactory operation, a regular inspection procedure must be implemented to replace worn or damaged parts before they become unsafe. The frequency of inspections should be determined by the specific application. The following list provides an inspection procedure for normal usage under normal conditions. When the unit is subjected to heavy usage, adverse atmospheric conditions, or moist conditions, shorter time periods must be assigned. In addition to the parts specifically mentioned in the succeeding list, all parts must be inspected for unusual wear, corrosion, or damage.

It is recommended that the unit be inspected monthly for signs of wear and corrosion on all parts, paying particular attention to the following:

- Tightness of all fasteners.
- Contactor and control station for burnt or pitted contacts and loose or corroded terminals.
- Cables and leads for broken wires, loose or corroded terminals and damaged insulation.
- Terminal board for loose or corroded connections.
- Trackwheels for wear of tread, flange and bearings.
- Gear portion of trackwheel and pinion for wear.
- Check the wear of top hook to load plate in trolley.
- Collector or power supply system for damage, wear corrosion and proper operation.
- A three-phase trolley is usually equipped with a motor brake. Check the wear on the brake lining and adjust the gap between the lining and the drum to ensure the brakes are working efficiently.

Frequent Inspection

For hoists in continuous service, operators should conduct frequent inspections at the beginning of each shift. Additionally, operators should conduct visual inspections during regular operation to check for damage or evidence of malfunction.

- 1. Operation:** Check for any visual signs or abnormal noises, such as grinding, which could indicate a potential problem. Check that the load chain is feeding through the hoist properly. If the chain binds or jumps, clean and lubricate it. If the problem persists, replace the chain. Do not operate the hoist until all problems have been corrected.
- 2. Hook:** Carefully check the hook. If the hook shows cracks, deformation, or wear exceeding 5% of its original size, it should be replaced. (Refer to the following table.)

Figure 9. MHP5337

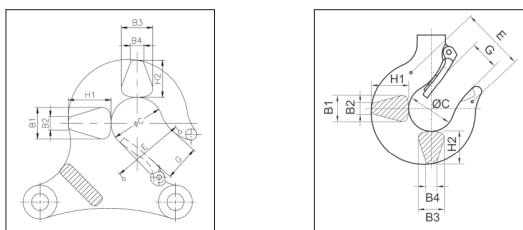

Top Hook

Bottom Hook

Table 7: Hook Specification and Dimensions

Models	Capacity (lbs)	Hook	Dimensions (mm)									Allow Stress (kg/mm ²)
			H1	B1	B2	H2	B3	B4	C	g	E	
EVLK0501	1,100	T	33	22	10	29	22	10	40	27	55	70
		B	33	23	9	29	23	9	40	28	60	70
EVLK1001	2,200	T	38	28	12	33	28	12	46	31	65	100
		B	33	23	9	29	23	9	40	28	60	70
EVLK1002	4,400	T	38	28	12	33	28	12	46	31	65	100
		B	45	31	10	41	31	10	46	36	75	70
EVLK2001	4,400	T; B	55	34	19	48	34	19	52	40	90	70
EVLK2501	5,500	T; B	55	34	19	48	34	19	52	40	90	70
EVLK1502	6,600	T; B	55	34	19	48	34	19	52	40	90	70
EVLK2502	11,000	T; B	66	44	23	60	44	23	62	45	100	70

Top Hook = T Bottom Hook = B

3. Load Chain:

- A distorted, elongated, or worn chain link will not fit properly on the load sprocket wheel, which may result in chain breakage and/or damage to the hoist unit. To ensure safe and efficient operation, check the pitch (inside length and width) and outside width of the chain links monthly according to the following table.

Figure 10. MHP5338

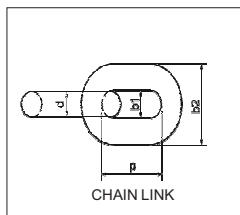
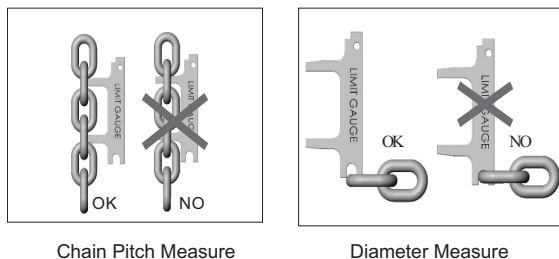

Table 8: Chain Dimensions

Models	Diameter (mm) (d)	Inside Length (mm) (p)	Inside Width (mm) (b1)	Outside Width (mm) (b2)	Breaking Load (kN)
EVLK0501	Ø 6.3	19.1	7.9	21.4	50
EVLK1001	Ø 7.1	20.2	8.1	23.2	63.3
EVLK1002	Ø 7.1	20.2	8.1	23.2	63.3
EVLK2001	Ø 10.0	30.2	12.5	32.2	128
EVLK2501	Ø 11.2	34	14	37.5	160
EVLK1502	Ø 10.0	30.2	12.5	32.2	128
EVLK2502	Ø 11.2	34	14	37.5	160

- b. The chain must be in perfect condition, with no defects or attachments.

Figure 11. MHP5339



Chain Pitch Measure

Diameter Measure

4. Chain Gauge - Wear and Stretch Measuring

- The chain gauge is useful and convenient for measuring.
 - Use a chain gauge to measure the pitch and diameter of the chain.
 - The chain ring must be measured, and the chain must be replaced when one of the chain rings is worn or stretched.
 - Using a chain fall will result in wear or stretching during operation, which will reduce its effectiveness.
 - Do not attempt to replace a chain fall by yourself. Please contact a service center or contractor for assistance.
 - The chain fall must be replaced whole instead of a partial part.
 - The load sheave, regulator, and chain-compressing wheel should be replaced at the same time as the second replacement.
- Controls:** While operating the hoist, verify that the response to the pendant is quick and smooth. Ensure that the controls return to neutral when released. If the hoist responds slowly or the movement is unsatisfactory, do not operate the hoist until all problems have been corrected.
 - Electrical System:** Visually inspect all connections and components for signs of damage or loose connections. Turn off and disconnect the power before removing the inspection covers, repairing any damage, or tightening the connections.
 - Hook Latch:** Ensure that the hook latch is present and functioning properly. Replace it if necessary.

⚠ CAUTION

Do not use the hoist if the hook latch is missing or damaged.

- Brake System:** Make sure the brake can hold the rated load without slipping. Check the air gap.
- Limit Switch:** Make sure the chain stopper is securely attached to the chain. For double fall hoists, ensure that the lower hook sheave block capscrews are tightened to the correct torque.
- Slip Clutch:** The slip clutch is factory-adjusted to slip at 125% of the hoist's rated capacity. However, if the wear-resistant lining overheats, the slip load will decrease.

Annual Inspection

WARNING

Ensure that this inspection is conducted by your authorized dealer.

- Check the gearing for any excessive wear or damage.
- Replace the gearbox lubricant completely (EVLK0501/1200cc, EVLK1001, EVLK1002/1400cc, EVLK2001, EVLK2501, EVLK1502, and EVLK2502/4000cc) according to the following table.

Note: We recommend using a lubricating oil equivalent to Shell Omala S4 GXV 680.

Table 9: Recommended Oils According to DIN 51354

ISO-VG DIN 51519 viscosity at 40 °C mm ² /s (cST)	Approximate viscosity of the VG Categories 50 °C mm ² /s (cST)	ARAL	BP	ESSO	MOBIL OIL	TEXACO	I..P.	ENI
VG 680	360	Aral Degol BG 680 - BMB 680	BP Energol GR - XP 680	Spartan EP 680	Mobilgear 636	Meropa 680	Mellana 680	Blasia 680

- Check the brake lining and ratchet pawl for wear and damage.
- Check the operation of pawl spring.
- After reassembling the above check, lift a load several times to ensure the hoist is performing well before beginning regular operation.

Lubrication

To ensure the hoist continues to operate satisfactorily, all lubrication points must be serviced with the correct lubricant at the proper time interval, as indicated for each assembly. Proper lubrication is one of the most important factors in maintaining efficient operation.

The lubrication intervals recommended in this manual are based on the hoist being operated intermittently for eight hours each day, five days per week. If the hoist is operated for more than eight hours per day or almost continuously, more frequent lubrication will be required. The recommended lubricant types are based on operation in an environment that is relatively free of dust, moisture, and corrosive fumes. Only use the lubricants recommended in this manual. Using other lubricants may affect the performance of the hoist. Approval for using other lubricants must be obtained from the **Ingersoll Rand** Technical Support Department or your distributor. Failure to properly lubricate the hoist and its associated components may result in damage.

Load Chain

WARNING

Failure to properly clean and lubricate the load chain can result in rapid wear and chain failure, which may cause severe injury or death, or substantial property damage.

1. Lubricate each link of the load chain weekly. Apply new lubricant over existing layer.
2. For severe applications or corrosive environments, lubricate more frequently than usual.
3. Use the same lubricant on the hook latch pivot point as you do on the load chain.
4. To remove rust or abrasive dust buildup, clean the chain with an acid-free solvent. After cleaning, lubricate the chain.
5. Use **Ingersoll Rand** 47580935001 oil.

Hook and Suspension Assemblies

1. Lubricate the lower hook and the latch pivot points. The hook and latch should pivot freely.
2. Use **Ingersoll Rand** 47580935001 oil.

Gears

The gear compartment is filled with grease at the factory. Replacing the grease during the lifetime of the hoist is not necessary.

Notes:

Notes:
