

OPERATOR'S MANUAL

PZ20X-XXX-XXX-BXX

INCLUDING: OPERATION, INSTALLATION, SAFETY AND MAINTENANCE

RELEASED: 11-26-21

REVISED: 3-27-26

(REV: F)

2" DIAPHRAGM PUMP

1:1 RATIO (METALLIC)



**READ THIS MANUAL CAREFULLY BEFORE INSTALLING,
OPERATING OR SERVICING THIS EQUIPMENT.**

It is the responsibility of the employer to place this information in the hands of the operator. Keep for future reference.

SERVICE KITS

Refer to Model Description Chart to match the pump material options.

637309-XXX for fluid section repair **with** seats (see page 8).

637309-XX for fluid section repair **without** seats (see page 8).

NOTE: This kit also contains several air motor seals which will need to be replaced.

637421 for air section repair (see page 10)

637374-X major air valve assembly (see page 11).

PUMP DATA

Models..... See Model Description Chart for "-XXX"

Pump Type..... Metallic Air Operated Double Diaphragm

Material..... see Model Description Chart

Weight

PZ20A- XAX -XXX-BXX	91.4 lbs (41.5 kgs)
PZ20A- XCX -XXX-BXX	147.4 lbs (66.9 kgs)
PZ20A- ASX -XXX-BXX, - BSX	149.8 lbs (68.0 kgs)
PZ20A- FSX -XXX-BXX	162.0 lbs (73.5 kgs)

(add 28.9 lbs [13.1 kg] for stainless steel air motor section)

Maximum Air Inlet Pressure 120 psig (8.3 bar)

Maximum Material Inlet Pressure 10 psig (0.69 bar)

Maximum Outlet Pressure 120 psig (8.3 bar)

Maximum Flow Rate 172 gpm (651 lpm)

Displacement / Cycle @ 100 psig. 1.4 gal. (5.3 lit.)

Maximum Particle Size 1/4" dia. (6.4 mm)

Maximum Temperature Limits (diaphragm / ball / seat material)

E.P.R. / EPDM	-60° to 280° F (-51° to 138° C)
Hytrel®	-20° to 180° F (-29° to 82° C)
PVDF	10° to 200° F (-12° to 93° C)
Nitrile	10° to 180° F (-12° to 82° C)
Santoprene®	-40° to 225° F (-40° to 107° C)
PTFE	40° to 225° F (4° to 107° C)
EPDM-Backed PTFE	40° to 266° F (4° to 130° C)
Viton®	-40° to 350° F (-40° to 177° C)

Dimensional Data..... see page 12

Noise Level @ 70 psig, 60 cpm^①. 85.0 dB(A)^②

① Tested with 67263 muffler assembly installed.

② The pump sound pressure levels published here have been updated to an Equivalent Continuous Sound Level (LA_{eq}) to meet the intent of ANSI S1.13-1971, CA-GI-PNEUROP S5.1 using four microphone locations.

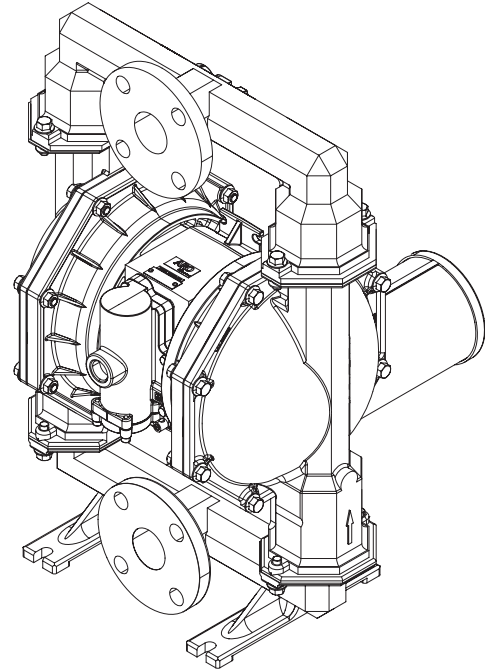

MODEL PZ20X-FXX

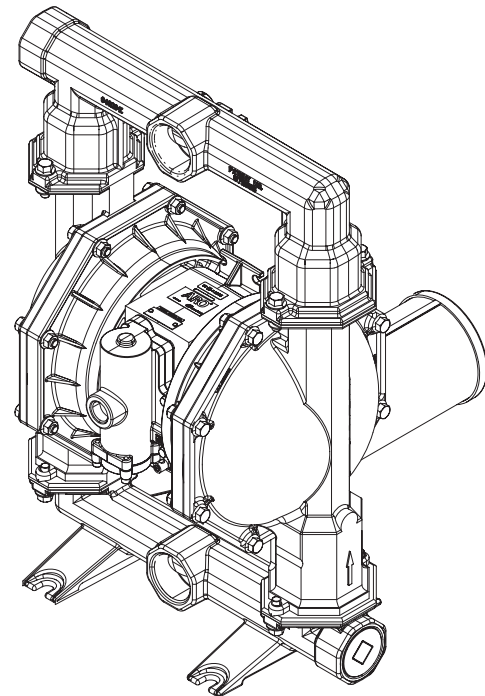

**MODEL PZ20X-AXX
PZ20X-BXX**

Figure 1

ARO

209 NORTH MAIN STREET – BRYAN, OHIO 43506

① (800) 495-0276 • FAX (800) 892-6276

© 2026

arozone.com

ARO®

MODEL DESCRIPTION CHART

Model Code Explanation

PZ20 X - X X X - X X X - B X X

Air Motor / Air Cap Material

- A - Aluminum
- S - Stainless Steel

Fluid Connection

- A - 2 - 11-1/2 NPT - 1
- B - Rp 2 (2 - 11 BSP parallel)
- F - 2" ANSI / DIN Flange

Fluid Caps & Manifold Material

- A - Aluminum
- C - Cast Iron
- S - Stainless Steel

Hardware Material

- P - Carbon Steel
- S - Stainless Steel

Seat Material

- A - Santoprene
- C - Hytrel
- E - Carbon Steel
- F - Aluminum
- G - Nitrile
- H - Hard 440 Stainless Steel
- K - PVDF
- S - 316 Stainless Steel

Ball Material

- A - Santoprene
- C - Hytrel
- G - Nitrile
- S - Stainless steel
- T - PTFE
- V - Viton

Diaphragm Material

- A - Santoprene
- C - Hytrel
- G - Nitrile
- L - Long Life PTFE
- M - Medical Grade Santoprene
- P - EPDM-Backed PTFE
- T - PTFE / Santoprene
- V - Viton

Revision

- B - Revision

Specialty Code 1 (Blank if no Speciality Code)

- 0 - Standard Valve Block

Specialty Code 2 (Blank if no Speciality Code)

- 0 - No Option

NOTICE: All possible options are shown in the chart, however, certain combinations may not be recommended. Consult a representative or the factory if you have questions concerning availability.

OPERATING AND SAFETY PRECAUTIONS

READ, UNDERSTAND AND FOLLOW THIS INFORMATION TO AVOID INJURY AND PROPERTY DAMAGE.



All diaphragm pump models listed in the Declarations of Conformity 5 and 6 (located near the end of the manual) conform to the requirements of the EU "Machinery Directive," UK regulation "Supply of Machinery (Safety) Regulations" 2008 (SI 2008/1597), and can be used in potentially explosive atmosphere areas with Zone 0/20 inside and outside the pump, but ONLY when the special conditions listed below under the section "SPECIFIC CONDITIONS OF SAFE USE FOR EXPLOSIVE ATMOSPHERES" are followed. The definitions for "Potentially Explosive Atmospheres" varies by geographical region around the world, and is summarized in the section below.

You must read and follow the detailed explanation of these hazards and follow the appropriate instructions noted in this manual for safe installation and operation.

SAFETY INFORMATION - EXPLANATION OF SAFETY SIGNAL WORDS:

⚠ WARNING WARNING indicates a hazardous situation which, if not avoided, could result in death or serious injury.

⚠ CAUTION CAUTION, used with the safety alert symbol, indicates a hazardous situation which, if not avoided, could result in minor or moderate injury.

NOTICE NOTICE is used to address practices not related to personal injury.

SPECIFIC CONDITIONS OF SAFE USE FOR EXPLOSIVE ATMOSPHERES :

These pumps can be used in an area with Zone 0/20 inside and outside the pump.

⚠ WARNING Non-compliance with any of these special conditions could create an ignition source that may ignite any potentially explosive atmospheres.

⚠ WARNING POTENTIAL ELECTROSTATIC CHARGING HAZARD. Clean only with a damp cloth.

⚠ WARNING STATIC SPARK. Can cause explosion resulting in severe injury or death. Ground pump and pumping system.

- Sparks can ignite flammable material and vapors.
- The pumping system and object being sprayed must be grounded when it is pumping, flushing, recirculating or spraying flammable materials such as paints, solvents, lacquers, etc. or used in a location where surrounding atmosphere is conducive to spontaneous combustion. Ground the dispensing valve or device, containers, hoses and any object to which material is being pumped.
- Use the pump grounding lug provided on metallic pumps for connection of a ground wire to a good earth ground source. Use Aro Part No. 66885-1 Ground Kit or a suitable ground wire (10 AWG or thicker).
- Pumps that will operate in environments defined as "hazardous locations" or "Potentially Explosive Atmospheres" must only be installed, connected and set-up by qualified personnel with knowledge and understanding of protection classes, regulations and provisions for apparatus in hazardous areas, for the region where the pump will operate.

- Secure pump, connections and all contact points (feet must be bolted) and provide clearance around the pump to avoid vibration and generation of contact or static spark.
- Consult local building codes and electrical codes for specific grounding requirements.
- After grounding, periodically verify continuity of electrical path to ground. Test with an ohmmeter from each component (e.g. hoses, pump, clamps, container, spray gun, etc.) to ground to insure continuity:
 - For "intrinsically safe" applications: ohmmeter should show less than 1 ohm.
 - For "ordinary" applications: ohmmeter should show less than 5 ohms.
 - Pump components surface resistance: materials are generally considered conductive with resistance less than 1×10^6 ohms.
- Submerge the outlet hose end, dispensing valve or device in the material being dispensed if possible. (Avoid free streaming of material being dispensed.)
- Use hoses incorporating a static wire or use groundable piping.
- Use a grounded exhaust hose between the pump and the muffler. (Refer to minimum size under Installation.)
- Use proper ventilation.
- Keep flammables away from heat, open flames and sparks.
- Keep containers closed when not in use.
- ⚠ WARNING** FOR MODELS CONTAINING ALUMINUM ENCLOSURES. Pumps must be mounted in such a manner as to eliminate the risk of sparks caused by friction or impact.
- Protect pump from external damage.
- Regularly inspect coatings for damage and if damage occurs do not use in Zone 0/20.
- ⚠ WARNING** EXPLOSION HAZARD. Models containing aluminum wetted parts cannot be used with 1,1,1-trichloroethane, methylene chloride or other halogenated hydrocarbon solvents which may react and explode.
- ⚠ WARNING** EXPLOSION HAZARD: Ensure that the pump will not exceed a maximum temperature of 25° C (77° F) lower than the auto ignition-temperature of the fluid being pumped.
- Check pump motor section, fluid caps, manifolds and all wetted parts to assure compatibility before using with solvents of this type.
- ⚠ WARNING** If elevated temperatures or inlet pressure levels are detected, shut the pump off and discontinue its use until it can be inspected and/or repaired.
- The following conditions apply if fluid temperature, air inlet temperature and air inlet pressure are not controlled within the process:
 - Sensors used for measuring the inlet air and fluid temperature and over pressure of inlet air must be connected to a monitoring and shutdown system which is sufficiently reliable and compliant with the requirements for ATEX Safety related devices as defined in Annex II Clause 1.5.1 of Directive 2014/34/EU (i.e. b2 (SIL2) as defined by EN ISO 80079-37cl 6.5).

- Associated programmable electronic devices forming a part of ignition protection systems must be installed in a safe area or be suitably certified ATEX rated for the zone into which where are installed.
- The ignition protection system, when installed, is to be subjected to functional and accuracy tests to ensure shutdown occurs if the limits specified by the manufacturer are exceeded.
- Trip points for the temperature and pressure monitoring system shall be set such that shutdown of the pump occurs if air inlet pressure exceeds 120 PSIG or if the air inlet or fluid temperature exceeds the limitation on page 5.

⚠ WARNING Do not perform maintenance or repairs in an area where explosive atmospheres are present. Prior to maintenance, ensure unit is unplugged and fully de-energized.

NOTICE Only FML-2 grease should be employed for lubrication of moving part.

⚠ WARNING **MAXIMUM SURFACE TEMPERATURE LIMITS.** Maximum temperatures are based on mechanical stress only. Certain chemicals will significantly reduce maximum safe operating temperature. Consult the chemical manufacturer for chemical compatibility and temperature limits.

- The actual surface temperature of the pumps depend on the running conditions of the pump, the materials of construction, the temperature of the fluid pumped, and the environmental conditions.

GENERAL PRODUCT SAFETY INFORMATION:

⚠ WARNING **EXCESSIVE AIR PRESSURE.** Can cause personal injury, pump damage or property damage.

- Do not exceed the maximum inlet air pressure as stated on the pump model plate. When the pump is used in a forced-feed (flooded inlet) situation, a "Check Valve" must be installed at the air inlet.
- Be sure material hoses and other components are able to withstand fluid pressures developed by this pump. Check all hoses for damage or wear. Be certain dispensing device is clean and in proper working condition.

⚠ WARNING Pump exhaust may contain contaminants. Can cause severe injury. Pipe exhaust away from work area and personnel.

- Pipe the exhaust to a safe remote location when pumping hazardous or flammable materials.
- In the event of a diaphragm rupture material can be forced out of the air exhaust muffler.
- Use a grounded 1" minimum ID hose between the pump and the muffler.

⚠ WARNING **HAZARDOUS PRESSURE.** Can result in serious injury or property damage. Do not service or clean pump, hoses or dispensing valve while the system is pressurized.

- Disconnect air supply line and relieve pressure from the system by opening dispensing valve or device and / or carefully and slowly loosening and removing outlet hose or piping from pump.

⚠ WARNING **HAZARDOUS MATERIALS.** Can cause serious injury or property damage. Do not attempt to return a pump to the factory or service center that contains hazardous material. Safe handling practices must comply with local and national laws and safety code requirements.

- For ambient, process fluid and air inlet temperature see the temperature table on page 5.
- Ensure proper housekeeping to eliminate dust build-up on the pump. Certain dusts may ignite at pump surface temperature limits, as noted on page 5.
- For use in Explosive Gas Atmospheres the TEMPERATURE range rating is limited by the materials & seals used in the construction per possible product configuration. Material temperature limitations are provided and must not be exceeded in the application. The pumps follow ISO 80079-36:2016: Ex h IIC Ga.

- For use in Explosive Dust Atmospheres the TEMPERATURE range rating is limited by the materials & seals used in the construction per possible product configuration. Material temperature limitations are provided and must not be exceeded in the application. The pumps follow ISO 80079-36:2016: Ex h IIC Da.

⚠ WARNING Pump operation involves the risk of producing an electrostatic charge when flowing liquids. Medium and higher conductive fluids should be used as defined by EN IEC 60079-32-1:2018 Section 7.1.4. The minimum allowed fluid conductivity shall be as follows:

- 25 pS/m for fluids with dielectric constant less than 2.
- 50 pS/m for fluids with dielectric constant higher than 2.
- 100 pS/m for fluids with substantially higher dielectric constants than 2 or when it is unknown.

- Obtain Material Safety Data Sheets on all materials from the supplier for proper handling instructions.

⚠ WARNING **EXPLOSION HAZARD.** Models containing aluminum wetted parts cannot be used with 1, 1, 1 - Trichloroethane, Methylene Chloride or other Halogenated Hydrocarbon solvents which may react and explode.

- Check pump motor section, fluid caps, manifolds and all wetted parts to assure compatibility before using with solvents of this type.

⚠ WARNING **MISAPPLICATION HAZARD.** Do not use models containing aluminum wetted parts with food products for human consumption. Plated parts can contain trace amounts of lead.

⚠ CAUTION Verify the chemical compatibility of the pump wetted parts and the substance being pumped, flushed or recirculated. Chemical compatibility may change with temperature and concentration of the chemical(s) within the substances being pumped, flushed or circulated. For specific fluid compatibility, consult the chemical manufacturer.

⚠ CAUTION Be certain all operators of this equipment have been trained for safe working practices, understand it's limitations, and wear safety goggles / equipment when required.

⚠ CAUTION Do not use the pump for the structural support of the piping system. Be certain the system components are properly supported to prevent stress on the pump parts.

- Suction and discharge connections should be flexible connections (such as hose), not rigid piped, and should be compatible with the substance being pumped.

- ⚠ CAUTION** Prevent unnecessary damage to the pump.
Do not allow pump to operate when out of material for long periods of time.
- Dry running of the pump is acceptable provided that the cycles accumulated do not exceed the application specific maintenance interval.
 - Disconnect air line from pump when system sits idle for long periods of time.

⚠ CAUTION Use only genuine ARO replacement parts to assure compatible pressure rating and longest service life.

NOTICE Replacement warning labels are available upon request: "Static Spark and Diaphragm Rupture" pn 94080.

TEMPERATURE LIMITS

The seat, ball and diaphragm materials for metallic pumps establish the ambient and pump temperature limitations. Use the temperature table below and the model code for ball, seat, diaphragm material to determine the temperature range for each pump model. Model code is explained in detail on page 2.

Example: PZ10X-XXX-AAA-AXX. AAA code is located in the first temperature range in the table below.

Result: -20°C to +40°C ambient temperature limit and -40°C to +78°C pump temperature limit.

Ambient Temperature Limits	Air Inlet and Process Fluid Temperature Limits	Ball, Seat, Diaphragm Model Code Letters Example: PZ10X-XXX-XXX-AXX									
-20°C to +40°C -4°F to +104°F	-40°C to +78°C -40°F to +172°F	AAA	AAB	AAM	AAV	ASA	ASB	ASM	ASV	AVA	AVB
		AVM	AVV	EAA	EAB	EAV	ESA	ESB	ESV	EVA	EVB
		EVV	FAA	FAB	FAV	FSA	FSB	FSV	FVA	FVB	FVV
		HAA	HAB	HAV	HSA	HSB	HSV	HVA	HVB	HVV	SAA
		SAB	SAV	SSA	SSB	SSV	SVA	SVB	SVV	---	---
-20°C to +40°C -4°F to +104°F	-29°C to +78°C -20°F to +174°F	AAC	ACA	ACB	ACC	ACM	ACV	ASC	AVC	CAA	CAB
		CAC	CAM	CAV	CCA	CCB	CCC	CCM	CCV	CSA	CSB
		CSC	CSM	CSV	CVA	CVB	CVC	CVM	CVV	EAC	ECA
		ECB	ECC	ECV	ESC	EVC	FAC	FCA	FCB	FCC	FCV
		FSC	FVC	HAC	HCA	HCB	HCC	HCV	HSC	HVC	SAC
-12°C to +40°C +10°F to +104°F	-12°C to +78°C +10°F to +174°F	SCA	SCB	SCC	SCV	SSC	SVC	---	---	---	---
		AAG	ACG	AGA	AGB	AGC	AGG	AGM	AGV	ASG	AVG
		CAG	CCG	CGA	CGB	CGC	CGG	CGM	CGV	CSG	CVG
		EAG	ECG	EGA	EGB	EGC	EGG	EGV	ESG	EVG	FAG
		FCG	FGA	FGB	FGC	FGG	FGV	FSG	FVG	GAA	GAB
		GAC	GAG	GAM	GAV	GCA	GCB	GCC	GCG	GCM	GCV
		GGA	GGB	GGC	GGG	GGM	GGV	GSA	GSB	GSC	GSG
		GSM	GSV	GVA	GVB	GVC	GVG	GVM	GVV	HAG	HCG
		HGA	HGB	HGC	HGG	HGV	HSG	HVG	KAA	KAB	KAC
		KAG	KAV	KCA	KCB	KCC	KCG	KCV	KGA	KGB	KGC
		KGK	KGV	KSA	KSB	KSC	KSG	KSV	KVA	KVB	KVC
		KVG	KVV	SAG	SCG	SGA	SGB	SGC	SGG	SGV	SSG
		SVG	---	---	---	---	---	---	---	---	---
0°C to +40°C +32°F to +104°F	0°C to +78°C +32°F to +174°F	PAA	PAC	PAG	PAV	PCA	PCC	PCG	PCV	PGA	PGC
		PGG	PGV	PSA	PSC	PSG	PSV	PVA	PVC	PVG	PVV
+4°C to +40°C +40°F to +104°F	+4°C to +78°C +40°F to +174°F	AAL	AAT	ACL	ACT	AGL	AGT	ASL	AST	ATA	ATB
		ATC	ATG	ATL	ATM	ATT	ATV	AVL	AVT	CAL	CAT
		CCL	CCT	CGL	CGT	CSL	CST	CTA	CTB	CTC	CTG
		CTL	CTM	CTT	CTV	CVL	CVT	EAL	EAM	EAT	ECL
		ECM	ECT	EGL	EGM	EGT	ESL	ESM	EST	ETA	ETB
		ETC	ETG	ETL	ETM	ETT	ETV	EVL	EVM	EVT	FAL
		FAM	FAT	FCL	FCM	FCT	FGL	FGM	FGT	FSL	FSM
		FST	FTA	FTB	FTC	FTG	FTL	FTM	FTT	FTV	FVL
		FVM	FVT	GAL	GAT	GCL	GCT	GGL	GGT	GSL	GST
		GTA	GTB	GTC	GTG	GTL	GTM	GTT	GTV	GVL	GVT
		HAL	HAM	HAT	HCL	HCM	HCT	HGL	HGM	HGT	HSL
		HSM	HST	HTA	HTB	HTC	HTG	HTL	HTM	HTT	HTV
		HVL	HVM	HVT	KAL	KAM	KAT	KCL	KCM	KCT	KGL
		KGM	KGT	KSL	KSM	KST	KTA	KTB	KTC	KTG	KTL
		KTM	KTT	KTV	KVL	KVM	KVT	PAL	PAT	PCL	PCT
		PGL	PGT	PSL	PST	PTA	PTC	PTG	PTL	PTT	PTV
		PVL	PVT	SAL	SAM	SAT	SCL	SCM	SCT	SGL	SGM
		SGT	SSL	SSM	SST	STA	STB	STC	STG	STL	STM
		STT	STV	SVL	SVM	SVT	---	---	---	---	---
-20°C to +40°C -4°F to +104°F	-23°C to +66°C -9°F to +150°F	FAU	FCU	FSU	FUA	FUC	FUU	FUV	FVU	SAU	SCU
		SSU	SUA	SUC	SUU	SUV	SVU	---	---	---	---
-12°C to +35°C +10°F to +95°F	-12°C to +66°C +10°F to +150°F	FGU	FUG	SGU	SUG	---	---	---	---	---	---
		FTU	FUL	FUT	PAU	PCU	PGU	PSU	PUA	PUC	PUG
0°C to +40°C +32°F to +104°F	0°C to +66°C +32°F to +150°F	PUU	PUV	PVU	FTU	FUL	FUT	PTU	PUL	PUT	STU
		SUL	SUT	---	---	---	---	---	---	---	---
+4°C to +40°C +40°F to +104°F	+4°C to +130°C +40°F to +266°F	ETP	FTP	HTP	STP	---	---	---	---	---	---

GENERAL DESCRIPTION

The ARO diaphragm pump offers high volume delivery even at low air pressure and a broad range of material compatibility options are available. Refer to the model and option chart. ARO pumps feature stall resistant design, modular air motor / fluid sections.

Air operated double diaphragm pumps utilize a pressure differential in the air chambers to alternately create suction and a positive fluid pressure in the fluid chambers, ball checks insure a positive flow of fluid.

Pump cycling will begin as air pressure is applied and will continue to pump and keep up with the demand. It will build and maintain line pressure and will stop cycling once maximum line pressure is reached (dispensing device closed) and will resume pumping as needed.

AIR AND LUBE REQUIREMENTS

⚠ WARNING EXCESSIVE AIR PRESSURE. Can cause personal injury, pump damage or property damage. Do not exceed maximum inlet air pressure as stated on air motor plate.

- Filtered and oiled air will allow the pump to operate more efficiently and yield a longer life to operating parts and mechanisms.
- A filter capable of filtering out particles larger than 50 microns should be used on the air supply. There is no lubrication required other than the "O" ring lubricant which is applied during assembly or repair.
- If lubricated air is present, make sure that it is compatible with the Nitrile "O" rings in the air motor section of the pump.

TRANSPORT AND STORAGE

- Store in a dry place, do not remove product from box during storage.
- Do not remove protection caps from inlet and outlet prior to installation.
- Do not drop or damage box, handle with care.

INSTALLATION

- Pump cycle rate and operating pressure should be controlled by using an air regulator on the air supply.
- The outlet material volume is governed not only by the air supply but also by the material supply available at the inlet. The material supply tubing should not be too small or restrictive. Be sure not to use hose which might collapse.
- Use flexible connections (such as hose), at the suction and discharge, these connections should not be rigid piped and must be compatible with the material being pumped.
- Pipe exhaust away to a safe location. Use a suitable diameter grounded hose between pump and muffler. Refer to table for proper size.

Pump Series	2"
Hose Size (min ID)	1"

- Install a ground wire where applicable.
- Verify correct model / configuration prior to installation.
- Pumps are tested in water at assembly. Flush pump with compatible fluid prior to installation.
- When the diaphragm pump is used in a forced-feed (flooded inlet) situation, it is recommended that a "Check Valve" be installed at the air inlet.

- Flooded suction inlet pressure must not exceed 10 psig (0.69 bar).
- Always flush the pump with a solvent compatible with the material being pumped if the material being pumped will solidify when not in use for a period of time.

OPERATING INSTRUCTIONS

- Always flush the pump with a solvent compatible with the material being pumped if the material being pumped is subject to "setting up" when not in use for a period of time.
- Disconnect the air supply from the pump if it is to be inactive for a few hours.
- The outlet material volume is governed not only by the air supply, but also by the material supply available at the inlet. The material supply tubing should not be too small or restrictive. Be sure not to use hose which might collapse.
- When the diaphragm pump is used in a forced-feed (flooded inlet) situation, it is recommended that a "check valve" be installed at the air inlet.
- Secure the diaphragm pump legs to a suitable surface to insure against damage by vibration.

MAINTENANCE

- Certain ARO "Smart Parts" are indicated which should be available for fast repair and reduction of down time.
- Provide a clean work surface to protect sensitive internal moving parts from contamination from dirt and foreign matter during service disassembly and reassembly.
- Keep good records of service activity and include the pump in preventive maintenance program.
- Service kits are available to service two separate diaphragm pump functions: 1. AIR SECTION, 2. FLUID SECTION. The Fluid Section is divided further to match typical part Material Options.
- Before disassembling, empty captured material in the outlet manifold by turning the pump upside down to drain material from the pump.

DIAPHRAGM PUMP SERVICE

GENERAL SERVICE NOTES:

- Inspect and replace old parts with new parts as necessary. Look for deep scratches on metallic surfaces, and nicks or cuts in "O" rings.
- Tools needed to complete disassembly and repair:
 - 7/8" wrench, 1/2" socket or wrench, 3/8" socket or wrench, 3/8" Allen wrench, 10 mm Allen wrench, T-10 Torx screwdriver, torque wrench (measuring inch pounds), "O" ring pick.
- Keep good records of service activity and include pump in preventive maintenance program.
- USE ONLY GENUINE ARO REPLACEMENT PARTS TO ASSURE PERFORMANCE AND PRESSURE RATING.
- Repairs should be made only by authorized trained personnel. Contact your local authorized ARO Service Center for parts and customer service information.

Original instructions are in English. Other languages are a translation of the original instructions.

PARTS AND SERVICE KITS

Refer to the part views and descriptions as provided on pages 8 through 11 for parts identification and service kit information.

- Certain ARO “Smart Parts” are indicated which should be available for fast repair and reduction of down time.
- Service kits are divided to service two separate diaphragm pump functions: 1. AIR SECTION, 2. FLUID SECTION. The Fluid Section is divided further to match typical part Material Options.

FLUID SECTION DISASSEMBLY

1. Remove (61) outlet manifold and (60) inlet manifold.
2. Remove (22) balls, (19) “O” rings (if applicable) and (21) seats.
3. Remove (15) fluid caps.

NOTE: Only PTFE diaphragm models use a primary diaphragm (7) and a backup diaphragm (8). Refer to the auxiliary view in the Fluid Section illustration.

4. Remove the (14) screw, (6) diaphragm washer, (7) or (7 / 8) diaphragms and (5) backup washer.

NOTE: Do not scratch or mar the surface of (1) diaphragm rod.

FLUID SECTION REASSEMBLY

- Reassemble in reverse order. Refer to the torque requirements on page 9.
- Clean and inspect all parts. Replace worn or damaged parts with new parts as required.
- Lubricate (1) diaphragm rod and (144) “U” cups with Lubriplate® FML-2 grease (94276 grease packet is included in service kit).
- Be certain the diaphragm assembly bottoms out on the (1) rod, back off PTFE diaphragm assembly far enough to align holes.
- For models with PTFE diaphragms: Item (8) Santoprene diaphragm is installed with the side marked “AIR SIDE” towards the pump center body. Install the (7) PTFE diaphragm with the side marked “FLUID SIDE” towards the (15) fluid cap.
- Re-check torque settings after the pump has been re-started and run a while.

Note: For EPDM-backed PTFE diaphragms (diaphragm option “P”) SPECIAL INSTRUCTIONS. Refer to pages 13-18 for more detailed INSTALLATION SEQUENCES: Apply 5-8 psig of air pressure to ensure the first air connecting side of the air cap. Tighten EPDM-backed PTFE diaphragm on connecting rod, ensuring back side of diaphragm is flush with backup washer and connecting rod, then insert rod into pump center body. Push diaphragm to first side, then install diaphragm on opposite side and torque diaphragm screws on both sides. Next, install first side fluid cap and fasteners. Torque fasteners per torque schedule on page 9. Apply 5-8 psig of air pressure to slowly draw diaphragm down, taking care not to activate trip pin (and thus shifting the diaphragm). Install second fluid cap and fasteners. Torque fasteners on second side per torque schedule on page 9. Examine torque settings after the pump has been re-started and run for an extended period of time.

PARTS LIST / PZ20X-XXX-XXX-BXX FLUID SECTION

FLUID SECTION SERVICE KITS (637309 -XXX or 637309 -XX)

★ For Fluid Kits With Seats:

637309-XXX Fluid Section Service Kits include: Seats (see SEAT Option, refer to -XXX in chart below), Balls (see BALL Option, refer to -XXX in chart below), Diaphragms (see DIAPHRAGM Option, refer to -XXX in chart below), and items: 19, 70, 144 and 175 (listed below) plus 174 and 94276 Lubriplate FML-2 grease (page 10).

★ For Fluid Kits Without Seats:

637309-XX Fluid Section Service Kits include: Balls (see BALL Option, refer to -XX in chart below), Diaphragms (see DIAPHRAGM Option, refer to -XX in chart below), and items: 19, 70, 144 and 175 (listed below) plus 174 and 94276 Lubriplate FML-2 grease (page 10).

EXTERNAL HARDWARE OPTIONS PZ20X-XXX-XXX-BXX						
Item	Description (size)	Qty	PZ20X-XXP		PZ20X-XXS	
			Part No.	Mtl	Part No.	Mtl
26	Screw (M10 x 1.5 - 6g x 34 mm)	(8)	94409-1	[C]	94409-2	[SS]
27	Bolt (M10 x 1.5 - 6g x 45 mm)	(16)	94990-1	[C]	94990	[SS]
29	Nut (M10 x 1.5 - 6h)	(16)	94992-1	[C]	94992	[SS]

✓ Air Section Service Kit Parts, see pages 10 and 11.

COMMON PARTS					
Item	Description (size)	Qty	Part No.	Mtl	
1	Connecting Rod	(1)	97386	[C]	
43	Ground Lug (see page 11)	(1)	93004	[Co]	
★✓ 70	Gasket	(2)	94100	[B]	
★✓ 144	"U" Cup (3/16" x 1-3/8" OD)	(2)	Y186-51	[B]	
✓ 180	Gasket (0.406" ID x 0.031" thick)	(4)	94098	[Co]	

SEAT OPTIONS PZ20X-XXX-XXX-BXX							
★ "21"							
-XXX	Seat	Qty	Mtl	-XXX	Seat	Qty	[Mtl]
-AXX	94328-A	(4)	[Sp]	-HXX	94354	(4)	[SH]
-CXX	94328-C	(4)	[H]	KXX	94477-K	(4)	[K]
-EXX	95677	(4)	[C]	-SXX	94353	(4)	[SS]
-FXX	95673	(4)	[A]				
-GXX	94328-G	(4)	[B]				

BALL OPTIONS PZ20X-XXX-XXX-BXX							
★ "22" (2-1/2" dia.)							
-XXX	Ball	Qty	Mtl	-XXX	Ball	Qty	Mtl
-XAX	93358-A	(4)	[Sp]	-XSX	94805	(4)	[SS]
-XCX	93358-C	(4)	[H]	-XTX	93358-4	(4)	[T]
-XGX	93358-2	(4)	[B]	-VXX	93358-3	(4)	[V]

NOTE: Seat options -AXX, -CXX and -GXX do not require item 19 "O" ring.

DIAPHRAGM OPTIONS PZ20X-XXX-XXX-BXX											
-XXX	★ Service Kit With Seat	★ Service Kit Without Seat	★ "7"			★ "8"			★ "19" (1/8" x 3-5/8" OD)		
	-XXX = (Seat) -XXX = (Ball) -XXX = (Diaphragm)	-XX = (Ball) -XX = (Diaphragm)	Diaphragm	Qty	Mtl	Diaphragm	Qty	Mtl	"O" Ring	Qty	Mtl
-XXA	637309-XXA	637309-XA	94329-A	(2)	[Sp]	----	---	---	94356	(4)	[E]
-XXB	637309-XXB	637309-XB	94330-A	(2)	[Sp]	----	---	---	94356	(4)	[E]
-XXC	637309-XXC	637309-XC	94329-C	(2)	[H]	----	---	---	Y327-237	(4)	[V]
-XXG	637309-XXG	637309-XG	96330-2	(2)	[B]	----	---	---	Y325-237	(4)	[B]
-XXL	637309-XXL	637309-XL	94355-L	(2)	[L]	94330-A	(2)	[SP]	Y328-237	(4)	[T]
-XXM	637309-XXM	637309-XM	94329-M	(2)	[MSP]				Y328-237	(4)	[T]
-XXP	637309-XXP	637309-XP	98331	(2)	[TP]	----	---	---	Y328-237	(4)	[T]
-XXT	637309-XXT	637309-XT	94355-T	(2)	[T]	94330-A	(2)	[SP]	Y328-237	(4)	[T]
-XXV	637309-XXV	637309-XV	95344	(2)	[V]	----	---	---	Y327-237	(4)	[V]

CENTER SECTION OPTIONS PZ20X-XXX-XXX-BXX						
Item	Description (size)	Qty	Aluminum		Stainless Steel	
			PZ20A-XXX-XXX-BXX		PZ20S-XXX-XXX-BXX	
			Part No.	Mtl	Part No.	Mtl
5	Backup Washer	(2)	96503	[A]	94357-2	[SS]
68	Air Cap	(1)	94715-1	[A]	94349-1	[SS]
69	Air Cap	(1)	94715-2	[A]	94349-2	[SS]
74	Pipe Plug (1/4 - 18 N.P.T x 7/16")	(2)	Y17-51-S	[SS]	Y17-51-S	[SS]
126	Plug	(1)	Y17-13-S	[SS]	Y17-13-S	[SS]
131	Screw (M10 x 1.5 - 6g x 120 mm)	(4)	94531	[A]	96656	[SS]
★✓ 175	"O" Ring (3/32" x 1" OD)	(2)	Y325-117	[B]	----	---
★✓	(3/32" x 1-1/16" OD)	(2)	----	---	Y325-118	[B]
181	Roll Pin (5/32" OD x 3/4" long)	(4)	----	---	Y178-56-S	[SS]

MATERIAL CODE	
[A]	= Aluminum
[B]	= Nitrile
[C]	= Carbon Steel
[CI]	= Cast Iron
[Co]	= Copper
[E]	= E.P.R.
[H]	= Hytrel
[K]	= PVDF
[L]	= Long Life PTFE
[MSP]	= Medical Grade Santoprene
[SH]	= Hard Stainless Steel
[SP]	= Santoprene
[SS]	= Stainless Steel
[T]	= PTFE
[TP]	= EPDM-Backed PTFE
[V]	= Viton

MANIFOLD / FLUID CAP MATERIAL OPTIONS PZ20X-XXX-XXX-BXX										
Item	Description (size)	Qty	PZ20X-XAX-XXX		PZ20X-XCX-XXX		PZ20X-XSX-XXX		PZ20X-FSX-XXX	
			Part No.	[Mtl]	Part No.	[Mtl]	Part No.	[Mtl]	Part No.	[Mtl]
6	Diaphragm Washer	(2)	96503	[A]	94357-2	[SS]	94357-2	[SS]	94357-2	[SS]
9	Washer	(2)	93065	[SS]	93065	[SS]	93065	[SS]	93065	[SS]
14	Diaphragm Screw (5/8" - 18 x 2-1/2")	(2)	Y5-111-T	[SS]	Y5-111-T	[SS]	Y5-111-T	[SS]	Y5-111-T	[SS]
15	Fluid Cap	(2)	94325	[A]	94346	[CI]	95570	[SS]	95570	[SS]
60	Inlet Manifold	(1)	94327-[◆]	[A]	94347-[◆]	[CI]	95510-[◆]	[SS]	95512 [◆]	[SS]
61	Outlet Manifold	(1)	94326-[◆]	[A]	94348-[◆]	[CI]	95511-[◆]	[SS]	95513 [◆]	[SS]
63	Pipe Plug (2 - 11-1/2 NPT)	(2)	Y17-128	[A]	Y17-28-C	[C]	----	---	----	
	R 2 (2 - 11 BSP, taper)	(2)	94439-2	[A]	94439-1	[C]	----	---	----	

◆ For NPTF thread models (PZ20X-AXX-XXX-BXX) use „-1“. For BSP thread models (PZ20X-BXX-XXX-BXX) use „-2“.

✦ Flange models

PARTS LIST / PZ20X-XXX-XXX-BXX AIR MOTOR SECTION

② Indicates parts included in 637421 air section service kit shown below and items (70), (144), (175) and (180) shown on page 8.

Item	Description (size)	Qty	Part No.	Mtl
101	Center Body (PZ20A-XXX-XXX-BXX)	(1)	97031	[A]
	(PZ20S-XXX-XXX-BXX)	(1)	97040	[SS]
103	Bushing	(1)	97394	[D]
105	Screw (M6 x 1 - 6g x 20 mm)	(4)	95887	[SS]
111	Spool	(1)	95651	[D]
118	Actuator Pin (0.250" x 2.276" long)	(2)	94083	[SS]
121	Sleeve	(2)	94084	[D]
127	90° St. Elbow (1-1/2 - 11-1/2 NPT)	(1)	94860	[C/I]
128	Set Screw (1/4" - 20 x 1/4")	(2)	Y29-42-S	[SS]
② 132	Gasket	(1)	94099	[B]
133	Lockwasher (1/4") (PZ20A-XXX-XXX-BXX)	(3)	Y117-416-C	[C]
	(PZ20S-XXX-XXX-BXX)	(3)	Y14-416-T	[SS]
134	Screw (M6 x 1 - 6g x 35 mm)	(4)	95923	[SS]
135	Valve Block (PZ20A-XXX-XXX-BXX)	(1)	96334-1	[A]
	(PZ20S-XXX-XXX-BXX)	(1)	96337-1	[SS]
136	Plug (PZ20A-XXX-XXX-BXX)	(1)	96335	[A]
	(PZ20S-XXX-XXX-BXX)	(1)	96339	[SS]
② 137	"O" Ring (1/16" x 2" OD)	(1)	Y325-32	[B]
② 138	"U" Cup (3/16" x 1.792" OD)	(1)	95966	[B]
② 139	"U" Cup (3/16" x 1-1/4" OD)	(1)	Y186-50	[B]
140	Valve Insert	(1)	95650	[AO]
141	Valve Plate	(1)	95659	[AO]
⑥ ② 146	"O" Ring (3/32" x 1-1/16" OD)	(1)	Y325-118	[B]
⑥ ② 147	"O" Ring (1/8" x 1/2" OD)	(2)	Y325-202	[B]
⑦ ② 166	Track Gasket	(1)	94026	[B]

AIR MOTOR SECTION SERVICE

Service is divided into two parts - 1. Pilot Valve, 2. Major Valve.

GENERAL REASSEMBLY NOTES:

- Air Motor Section service is continued from Fluid Section repair.
- Inspect and replace old parts with new parts as necessary. Look for deep scratches on metallic surfaces, and nicks or cuts in "O" rings.
- Take precautions to prevent cutting "O" rings upon installation.
- Lubricate "O" rings with Lubriplate FML-2 grease.
- Do not over-tighten fasteners. Refer to torque specification block on view.
- Re-torque fasteners following restart.
- SERVICE TOOLS - To aid in the installation of (168) "O" rings onto the (167) pilot piston, use tool # 204130-T, available from ARO.

PILOT VALVE DISASSEMBLY

1. A light tap on (118) actuator pin should expose the opposite (121) sleeve, (167) pilot piston and other parts.
2. Remove (170) sleeve. Inspect inner bore of sleeve for damage.

PILOT VALVE REASSEMBLY

1. Clean and lubricate parts not being replaced from service kit.
2. Install new (171 and 172) "O" rings. Replace (170) sleeve.
3. Install new (168) "O" rings and (169) "U" cup - Note the lip direction. Lubricate and replace (167) pilot piston.
4. Reassemble remaining parts. Replace (173 and 174) "O" rings.

Item	Description (size)	Qty	Part No.	Mtl
② 167	Pilot Piston (includes 168 and 169)	(1)	67164	[D]
168	"O" Ring (3/32" x 5/8" OD)	(2)	94433	[U]
169	"U" Cup (1/8" x 7/8" OD)	(1)	Y240-9	[B]
170	Piston Sleeve	(1)	94081	[D]
② 171	"O" Ring (3/32" x 1-1/8" OD)	(1)	Y325-119	[B]
② 172	"O" Ring (1/16" x 1-1/8" OD)	(1)	Y325-22	[B]
② 173	"O" Ring (1/16" x 1-3/8" OD)	(2)	Y325-26	[B]
① ② 174	"O" Ring (1/8" x 1/2" OD)	(2)	Y325-202	[B]
② 176	Diaphragm (check valve)	(2)	94102	[Sp]
② 199	Track Gasket	(1)	95666	[B]
② 200	Gasket	(1)	95665	[B]
201	Muffler Kit (includes item 127)	(1)	67213	
233	Adapter Plate (PZ20A-XXX-XXX-BXX)	(1)	96336	[A]
	(PZ20S-XXX-XXX-BXX)	(1)	96338	[SS]
240	Screw (M6 x 1 - 6g x 16 mm)	(2)	95991	[SS]
② 241	Track Gasket	(1)	96344	[B]
② 242	"O" Ring (1/16" x 7/32" OD)	(1)	Y325-5	[B]
② 243	"O" Ring (1/8" x 5/8" OD)	(1)	Y325-204	[B]
② 244	"O" Ring (1/8" x 7/8" OD)	(1)	Y325-208	[B]
① ②	Lubriplate FML-2 grease	(1)	94276	
	Lubriplate Grease Packets (10)		637308	

① Items included in fluid section service kit, see pages 8 and 9.

⑥ Used on models PZ20S-XXX-XXX-BXX only.

⑦ Used on models PZ20A-XXX-XXX-BXX only.

MAJOR VALVE DISASSEMBLY

1. Remove (135) valve block and (233) adapter plate, exposing (132 and 166) gaskets and (176) checks.
2. Remove (233) adapter plate, releasing (140) valve insert, (141) valve plate, (199, 200 and 241) gaskets and (243 and 244) "O" rings.
3. Remove (136) plug and (137) "O" ring, releasing (111) spool.

MAJOR VALVE REASSEMBLY

1. Install new (138 and 139) "U" cups on (111) spool - **LIPS MUST FACE EACH OTHER.**
 2. Insert (111) spool into (135) valve block.
 3. Install (137 and 242) "O" rings on (136) plug and assemble plug to (135) valve block, securing with (105) screws.
 4. Install (140) valve insert, (141) valve plate, (199) gasket and (243 and 244) "O" rings into (135) valve block.
- NOTE:** Assemble (140) valve insert with "dished" side toward (141) valve plate. Assemble (141) valve plate with part number identification toward (140) valve insert.
5. Assemble (200 and 241) gaskets and (233) adapter plate to (135) valve block, securing with (240) screws.
 6. Assemble (132 and 166) gaskets and (176) checks to (101) center body.
 7. Assemble (135) valve block and components to (101) center body, securing with (134) screws.

MATERIAL CODE

[A]	= Aluminum
[AO]	= Alumina Oxide
[B]	= Nitrile
[Br]	= Brass
[C]	= Carbon Steel

MATERIAL CODE

[D]	= Acetal
[I]	= Iron
[SP]	= Santoprene
[SS]	= Stainless Steel
[U]	= Polyurethane

PARTS LIST / PZ20X-XXX-XXX-BXX AIR MOTOR SECTION

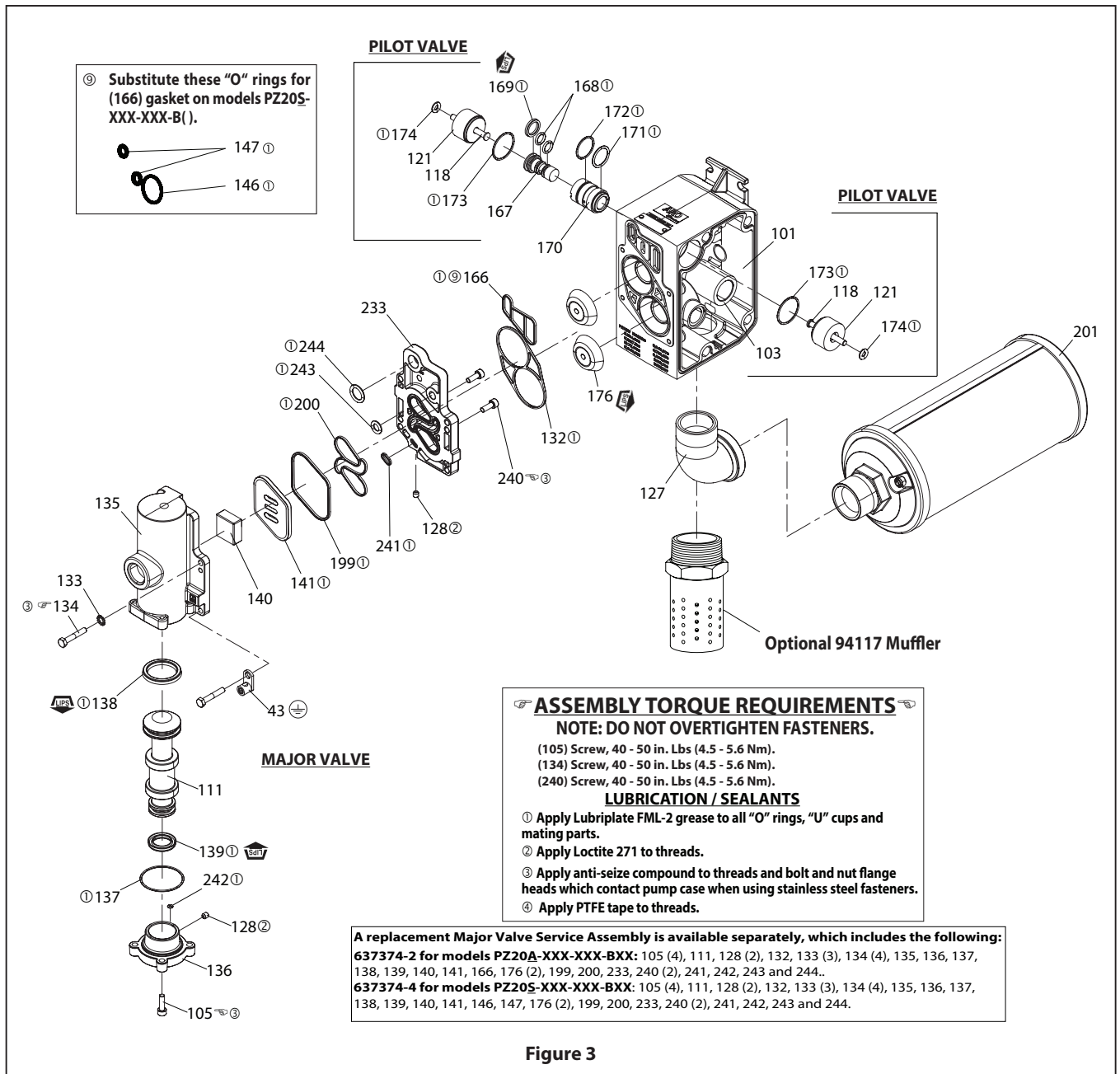

Figure 3

TROUBLESHOOTING

Product discharged from exhaust outlet.

- Check for diaphragm rupture.
- Check tightness of (14) diaphragm screw.

Air bubbles in product discharge.

- Check connections of suction plumbing.
- Check "O" rings between intake manifold and inlet side fluid caps.
- Check tightness of (14) diaphragm screw.

Motor blows air or stalls.

- Check (176) check valve for damage or wear.
- Check for restrictions in valve / exhaust.

Low output volume, erratic flow or no flow.

- Check air supply.
- Check for plugged outlet hose.
- Check for kinked (restrictive) outlet material hose.
- Check for kinked (restrictive) or collapsed inlet material hose.
- Check for pump cavitation - suction pipe should be sized at least as large as the inlet thread diameter of the pump for proper flow if high viscosity fluids are being pumped. Suction hose must be a non-collapsing type, capable of pulling a high volume.
- Check all joints on the inlet manifolds and suction connections. These must be air tight.
- Inspect the pump for solid objects lodged in the diaphragm chamber or the seat area.

DIMENSIONAL DATA

Dimensions shown are for reference only, they are displayed in inches and millimeters (mm).

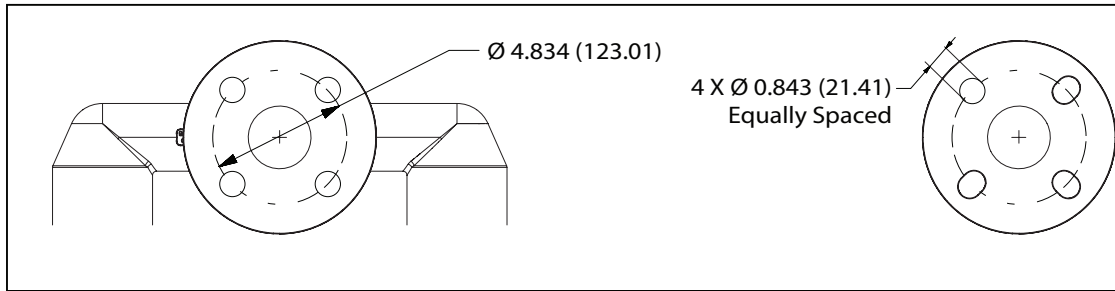
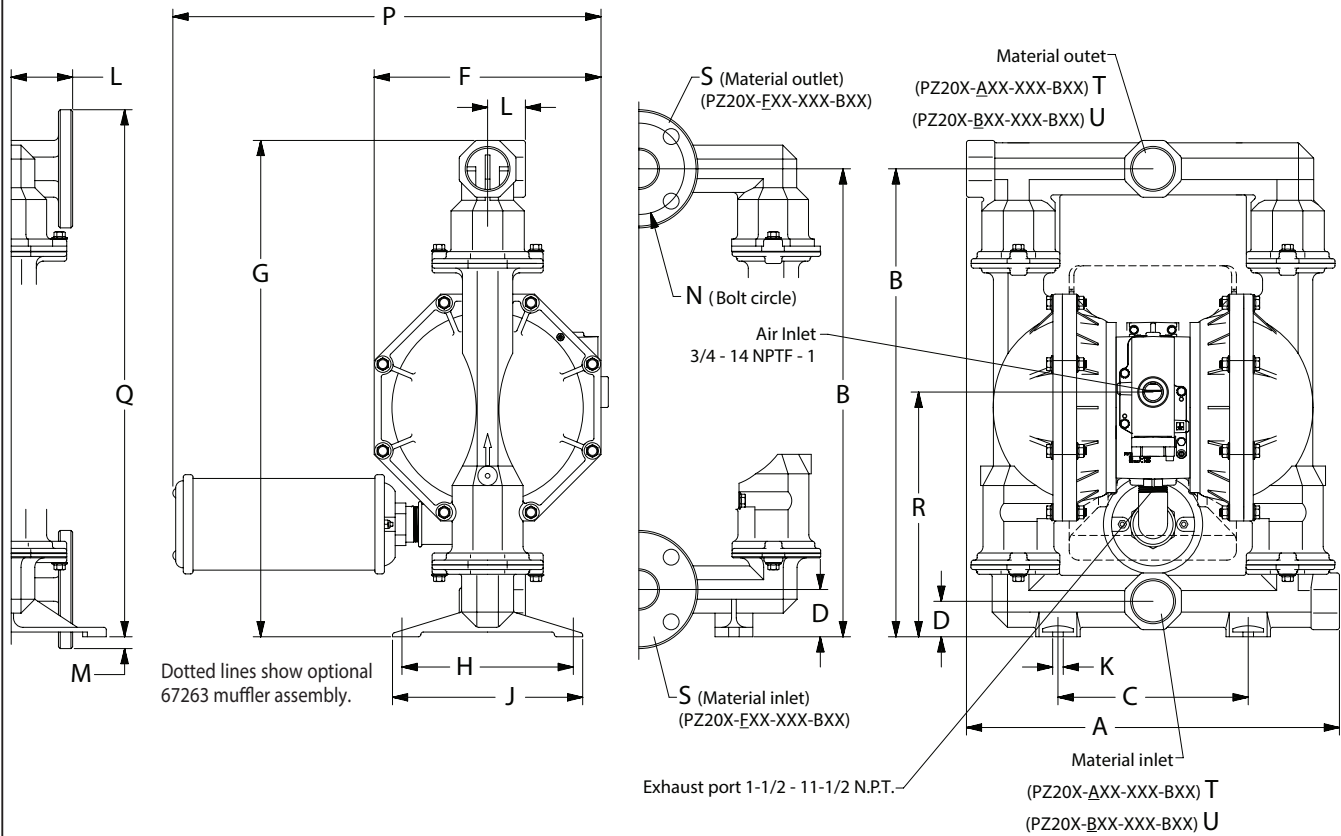

DIMENSIONS

- | | | | |
|---|--|--|--|
| <p>A - see below
 B - 24.75" (628.7 mm)
 C - 10.06" (255.6 mm)
 D - see below
 F - 12" (304.8 mm)
 I - Side Discharge Ports are not available on PZ20X-XSX-XB Models.</p> | <p>G - 26.25" (666.8 mm)
 H - 9.06" (230.2 mm)
 J - 10.06" (255.6 mm)
 K - 0.56" (14.3 mm)</p> | <p>L - see below
 M - 0.62" (15.9 mm)
 N - 4.834" (122.8 mm)
 P - 21.62" (548 mm)
 Q - 27.87" (708.0 mm)</p> | <p>R - see below
 S - 2" A.N.S.I. / DIN Flange
 T - 2 - 11-1/2 N.P.T.F. - 1
 U - Rp 2 (2 - 11 BSP, parallel)</p> |
|---|--|--|--|

	"A"	"D"	"L"	"R"
PZ20X-XAX-XXX-BXX	19.75" (501.7 mm)	1.87" (47.6 mm)	2" (50.8 mm)	12.93" (328.6 mm)
PZ20X-XCX-XXX-BXX	19.75" (501.7 mm)	1.87" (47.6 mm)	2" (50.8 mm)	12.93" (328.6 mm)
PZ20X-AHX-XXX-BXX	19.25" (488.7 mm)	2.5" (63.5 mm)	2.09" (53.0 mm)	13.56" (344.5 mm)
PZ20X-BHX-XXX-BXX	19.25" (488.7 mm)	2.5" (63.5 mm)	2.09" (53.0 mm)	13.56" (344.5 mm)
PZ20X-ASX-XXX-BXX	19.37" (492.1 mm)	2.5" (63.5 mm)	2.09" (53.0 mm)	13.56" (344.5 mm)
PZ20X-BSX-XXX-BXX	19.37" (492.1 mm)	2.5" (63.5 mm)	2.09" (53.0 mm)	13.56" (344.5 mm)
PZ20X-EHX-XXX-BXX	19.25" (488.7 mm)	2.5" (63.5 mm)	3.25" (82.6 mm)	13.56" (344.5 mm)
PZ20X-FSX-XXX-BXX	19.37" (492.1 mm)	2.5" (63.5 mm)	3.25" (82.6 mm)	13.56" (344.5 mm)

Figure 4

INSTALLATION SEQUENCE (FOR EPDM-BACKED PTFE COMPOSITE DIAPHRAGMS ONLY)

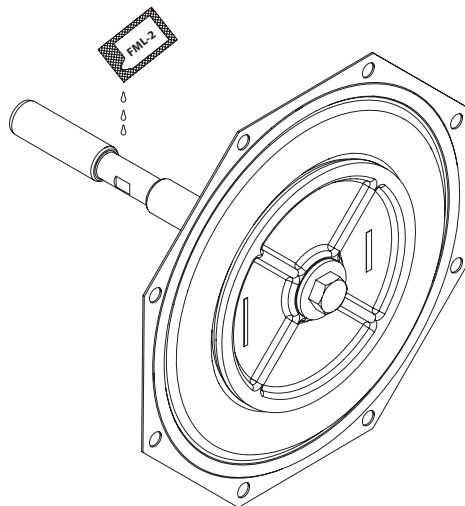
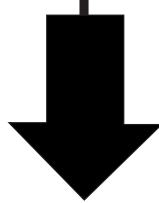
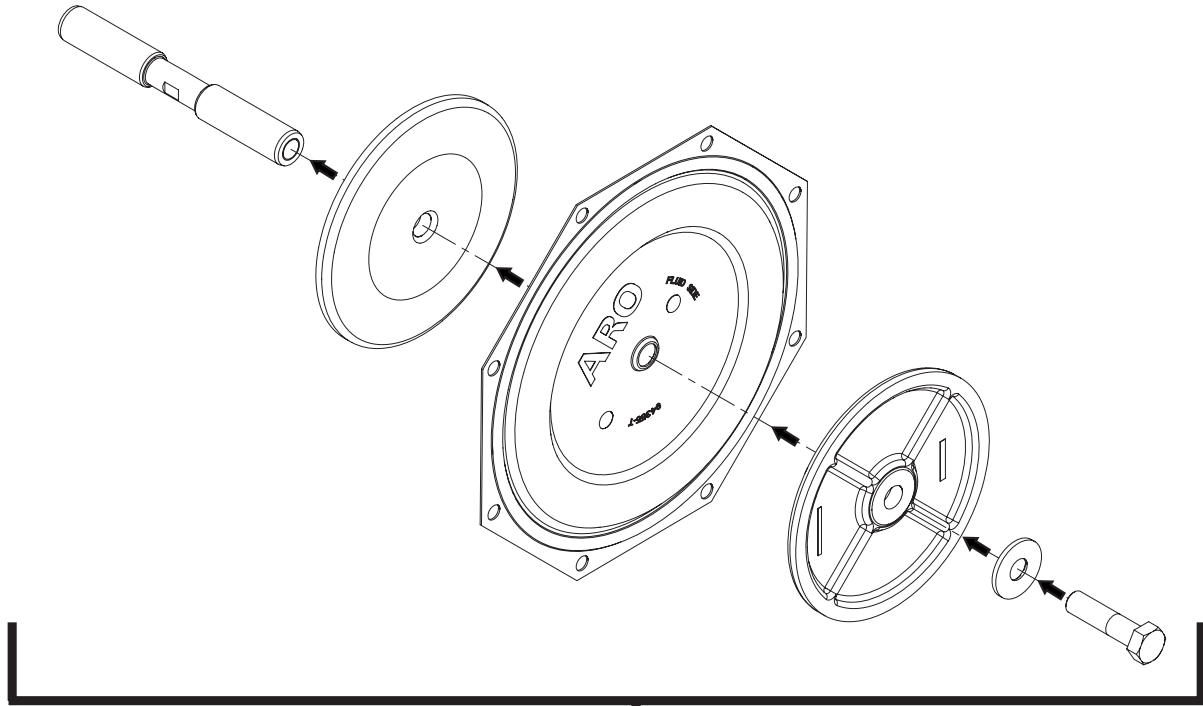

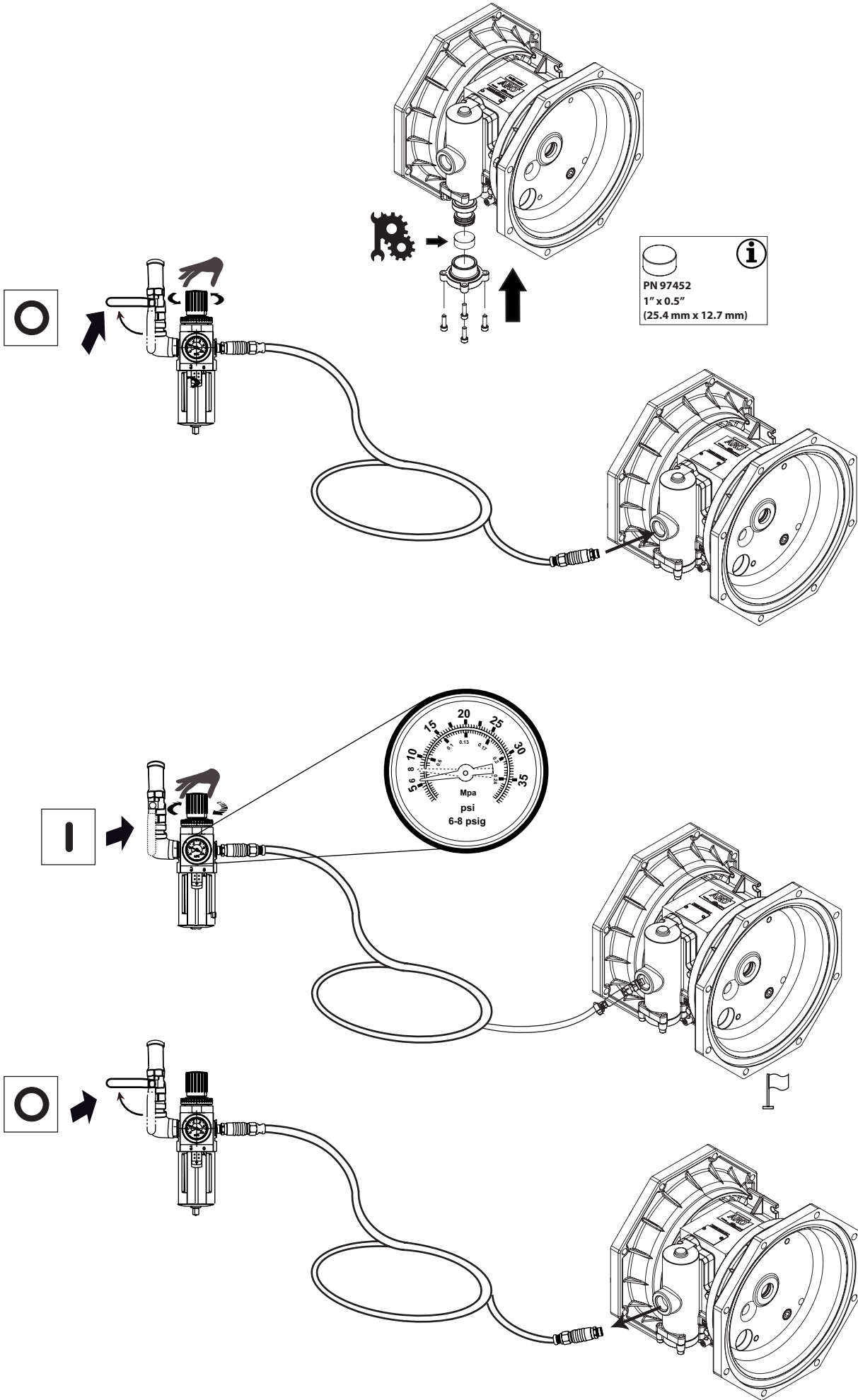

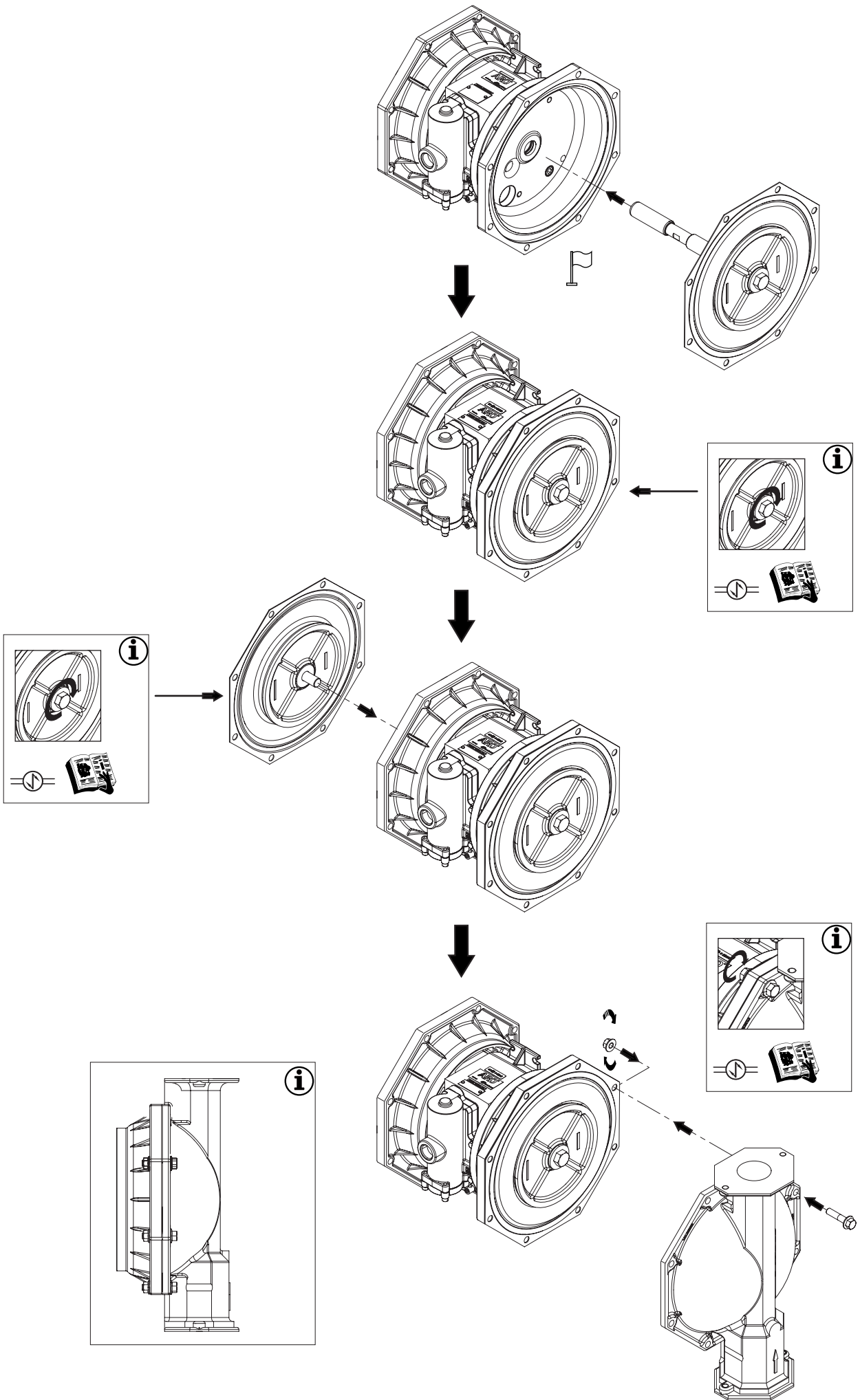

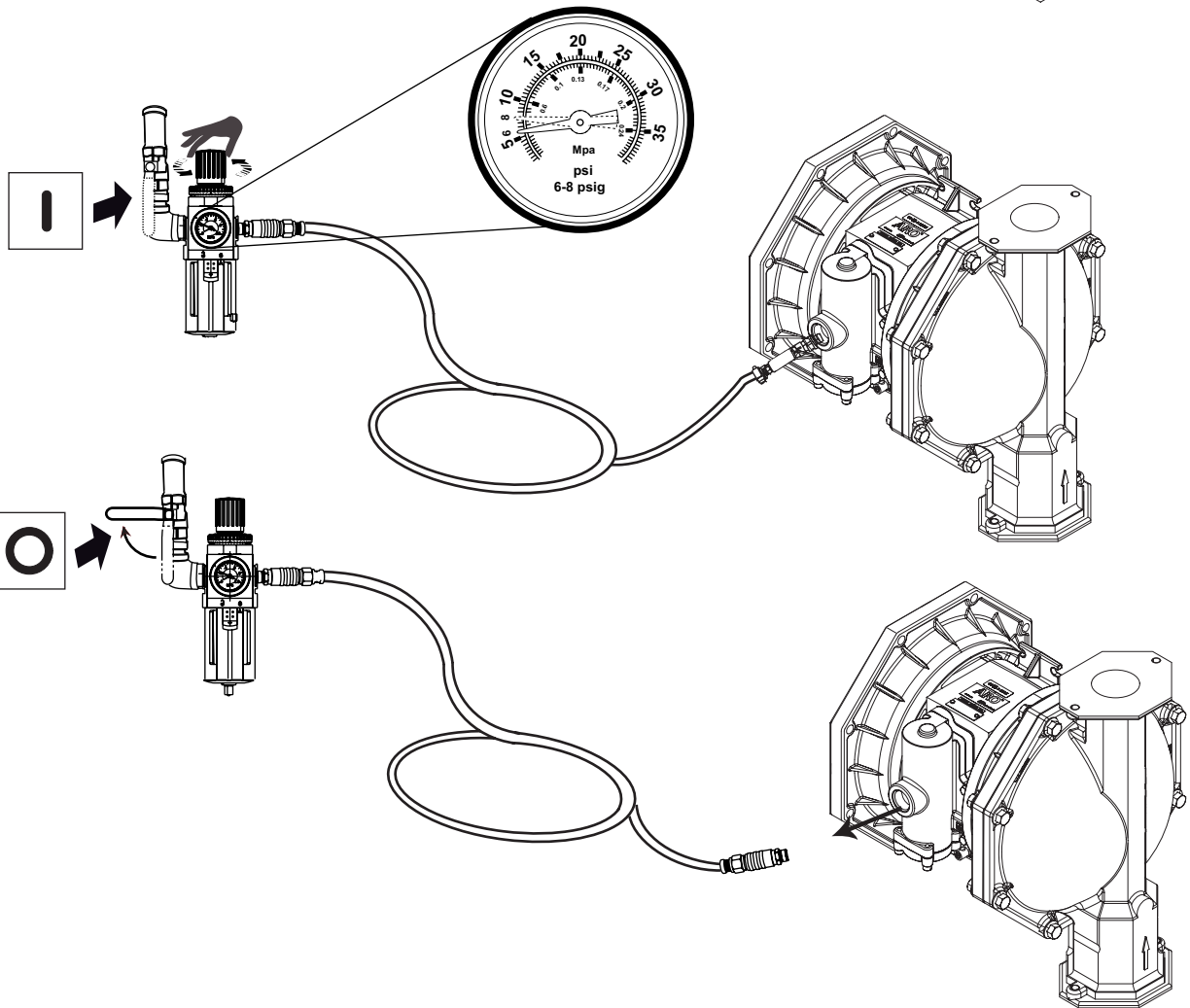
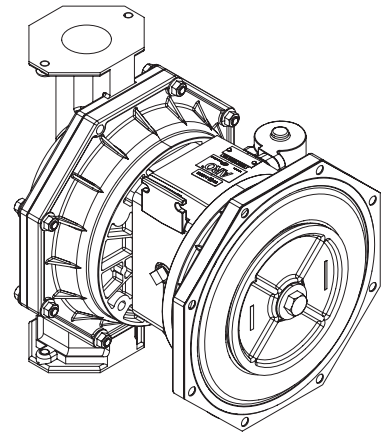
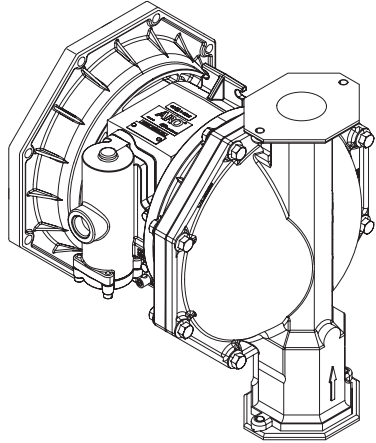
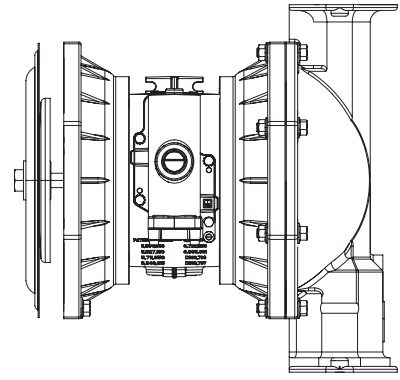
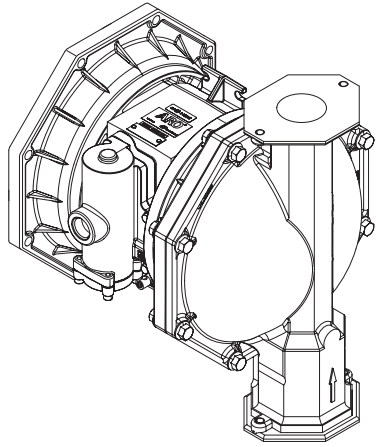

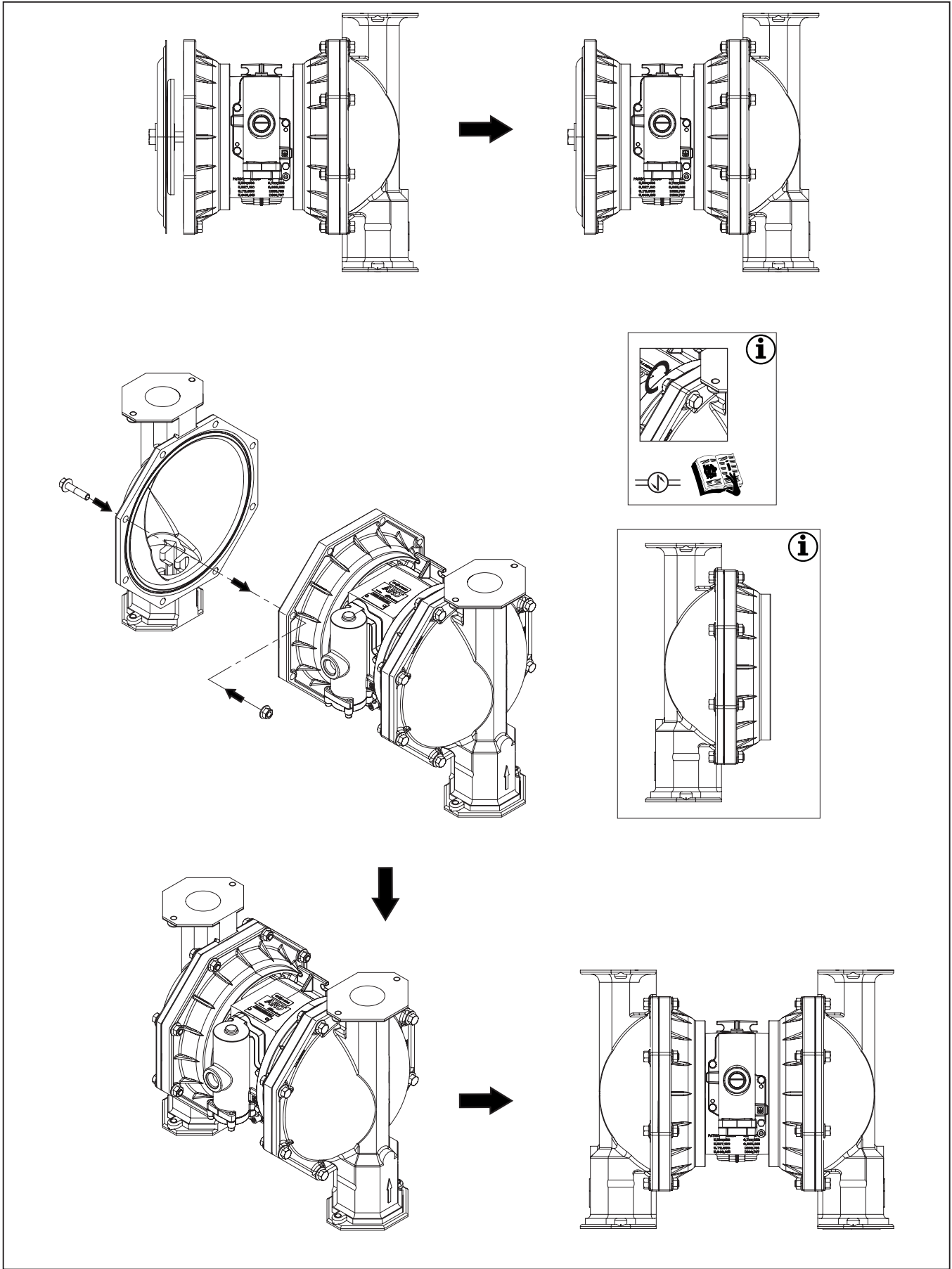

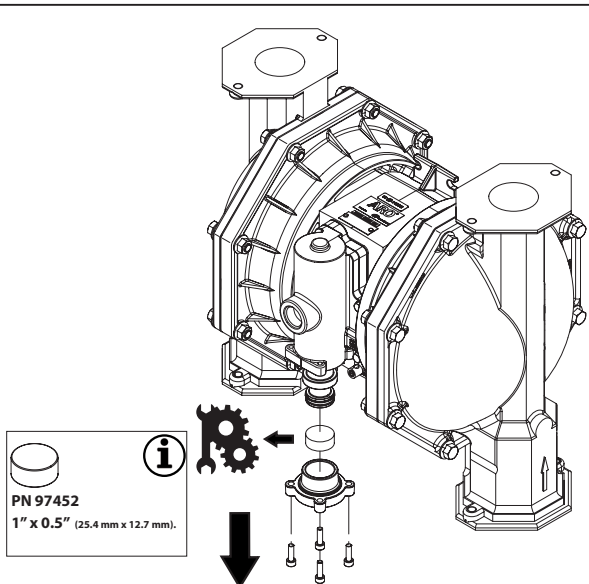





 **PN 97452**
1" x 0.5" (25.4 mm x 12.7 mm).







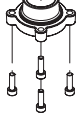

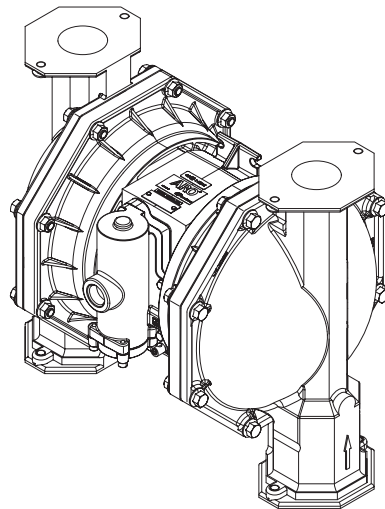
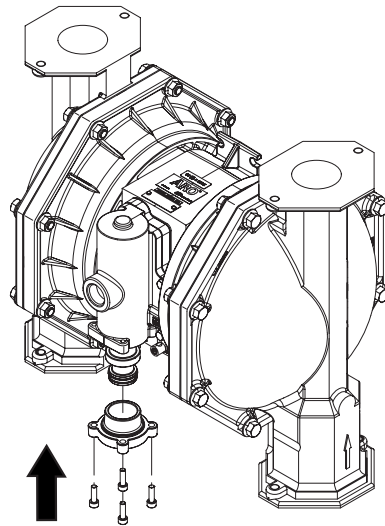

DECLARATION OF CONFORMITY



MANUFACTURED BY: INGERSOLL RAND INC

USA: 209 N. MAIN STREET, BRYAN, OHIO 43506

EU: 165 LAKEVIEW DRIVE, SWORDS, IRELAND

DECLARE UNDER OUR SOLE RESPONSIBILITY THAT THE:

TYPE / SERIES: AIR OPERATED DIAPHRAGM PUMPS

MODEL: PZ05X-XXX-XXX, PZ10X-XXX-XXX, PZ15X-XXX-XXX, PZ20X-XXX-XXX, PZ30X-XXX-XXX.

This product complies with the following European Community Directives:





2006/42/EC (Machinery), 2014/34/EU, 1999/92/EC, 1907/2006/EC, 2011/65/EU

The following Standards were used to verify compliance with the Directives:

EN ISO 80079-36:2016, EN ISO 80079-37:2016, EN IEC 60079-0:2018, EN ISO 12100:2010

Standards Applied Marking:



-  II 1 G Ex h IIC T4 Ga TX
-  II 1 D Ex h IIIC 135°C Da TX
-  II 1 G Ex h IIC T3 Ga TX
-  II 1 D Ex h IIIC 200°C Da TX

TX - for ambient temperature see certificate
ERO21ATEX0012X and page 5 of the operator's manual

Name of Notified Body: Element Materials Technology
Notified Body Number: 2812

Approved by:

Willem Kuyvenhoven, Global Engineering Leader

Thomas Mapelli, Application Sales Engineer &
Authorized Manufacturer Representative

Date: 1 JANUARY 2026

DOC-5

