

Gardner

Denver[®]

Dry Bulk Conveying **Solutions**



Why Gardner Denver?

We Understand Your Market

When you buy from Gardner Denver, you're not simply buying a product. As our customer, you are investing in over 150 years of quality, innovation and service you can trust.

Global Supply Capability

Gardner Denver is the only truly global manufacturer in the mobile pneumatic conveying industry. This allows us to leverage capacity to bring products that make sense for your business.

Engineering Research & Development

Gardner Denver is a world leader in engineering and design. All our products have undergone an extensive research and development process.

Individual processes include: virtual modeling and testing, finite element analysis; and thermographic, sound, and individual component testing.

The end result is a product that meets the very highest standards in performance and reliability.

Portfolio of Products

Gardner Denver has the broadest product offering in the business. No matter your requirements, we have a solution for you.

Distribution & Service Network

Gardner Denver is proud to offer the most extensive and qualified distributor network available. Local Distributors offer 24-hour service and technical support for all your needs.

We Provide Solutions

It does not matter what you do. We can help you get it done.

Manufacturing

Gardner Denver products are manufactured in our ISO 9001 certified facility in Sedalia, Missouri. Materials are machined on the latest equipment. Products pass quality tests before release to the field, ensuring robust performance for you.

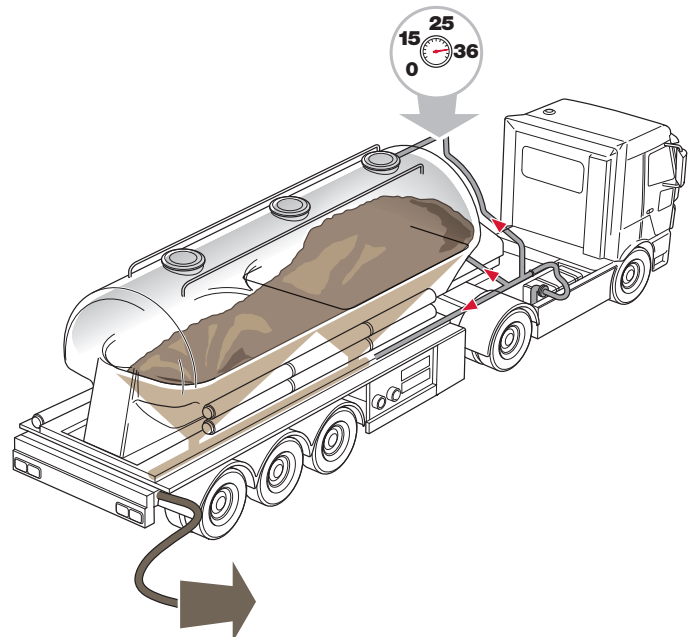



*"Gardner Denver machines
can move everything!"*

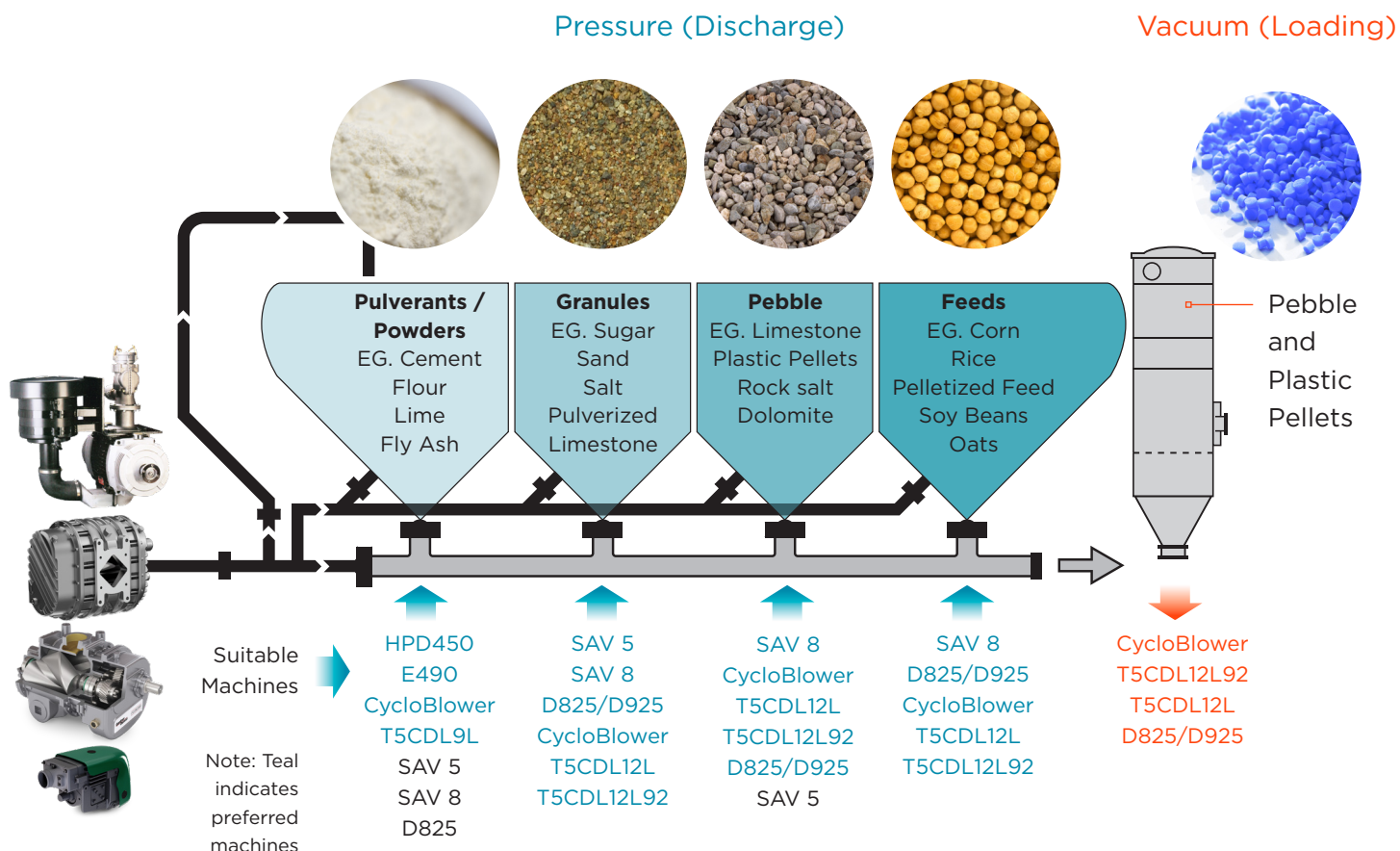

Designed exclusively for off loading dry products in the tank-truck markets.

Helical Screw Blower CycloBlower

- Proprietary helical design blower
- Multiple configuration options available to suit any application
- Ideal for pressure discharge and vacuum loading
- Up to 45 pounds lighter than traditional blowers
- Saves almost two gallons of fuel per delivery compared to traditional blowers

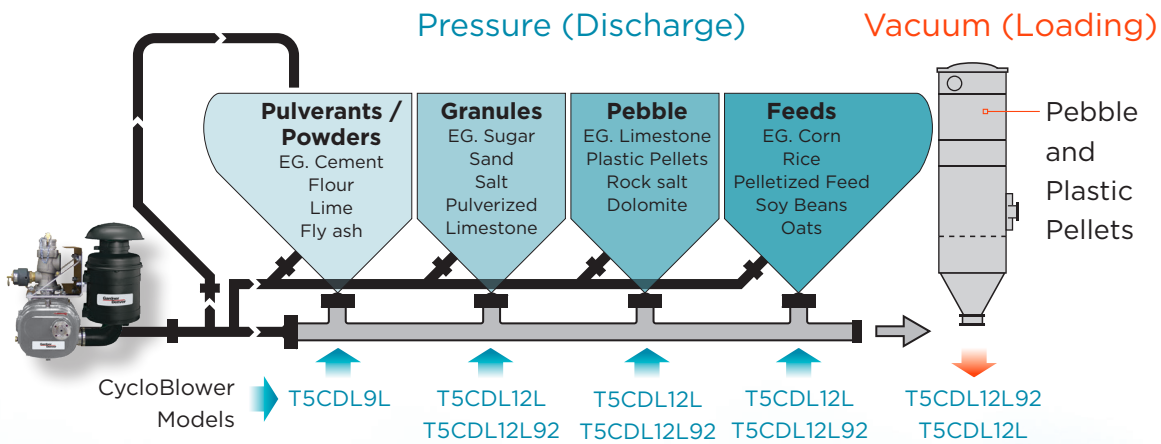

Trusted for Generations...



"#1 Industry choice for over 50 years."

"Over 50,000 drivers can't be wrong."

CYCLOBLOWER DELIVERY

Model	Flow Rate CFM	Pressure PSI	Vacuum inHg
T5CDL9L	625	18 cont. & 20 int.	17
T5CDL12L	810	18 cont. & 20 int.	17
T5CDL12L92	1040	18 cont. & 20 int.	17

Maximum flow and pressure listed. Actual performance may vary based on system design, environment, and maintenance.

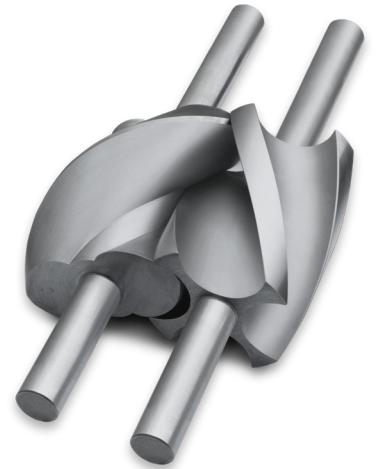

*"Every driver knows a driver who
LOVES a CycloBlower."*



Rotary Screw Compressor CycloSaver Transport Series

It's Innovative

The CycloSaver utilizes a proprietary rotary screw design.

It's Flexible

The pressure and flow ranges produced by the CycloSaver allow all dry bulk solids to be discharged at optimum flow rates.

It's Light

CycloSaver weighs as little as 257 pounds offering increased payload capacity.

It's Efficient

Discharge times are improved by up to 40%. The CycloSaver reduces horsepower consumption per cfm.

It's Powerful

Capable of pressure delivery up to 36 psi continuous.

It's Cool

Lowest output temperatures of any comparable design.

It's Compact

Easy installation.

...It's the Future!

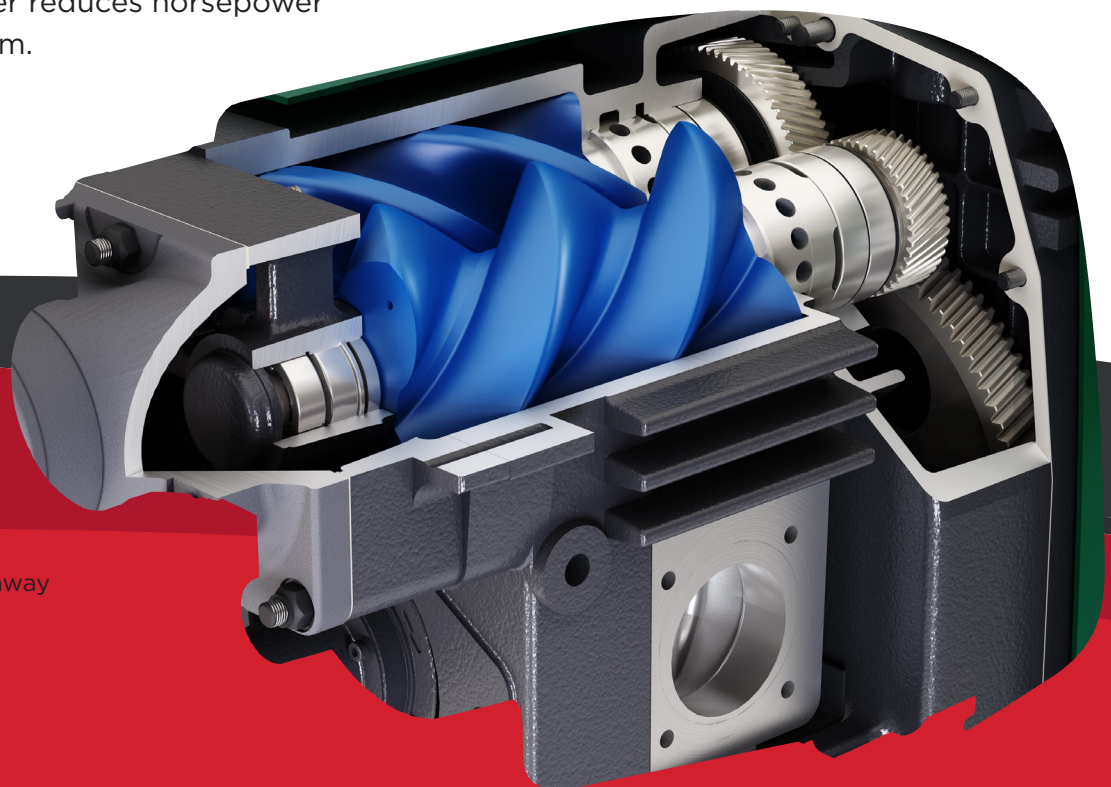

SAV 8 Compressor Cutaway

SAV 8 COMPRESSOR



CYCLOSAVER DELIVERY

Model	Flow Rate CFM	Pressure PSIG, CONTINUOUS
SAV5	415	36
SAV8	650	32

Maximum flow and pressure listed. Actual performance may vary based on system design, environment, and maintenance.



CycloSaver compact installation

D800

Introduced in the U.S.

1980



D800

First straight-lobe blower to deliver 18 psi & 17 inHG.

1991



D807/D907

D807 launched as first straight-lobe blower to achieve 20 psi continuous pressure, implemented diamond shape port for reduced noise & added cooling fins and reinforcing ribs for added strength. D907 model also introduced for higher flow requirements.

1997

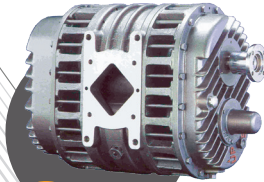

D825/D925

Continuous pressure capability increased to 19 psi and bi-directional rotation added for D925 model. Increased bearing life on both model sizes.

2026

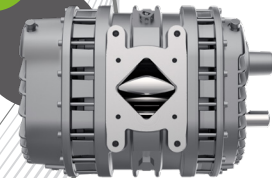

Bi-Lobe Blowers D825 & D925

Gardner Denver is proud to be an industry leader and innovator with the widest selection of dry bulk blower solutions. Each solution designed to efficiently load and unload dry bulk pneumatic trailers, ensuring durable and effective performance for dry bulk applications.

With the broadest product offering in the industry, Gardner Denver guarantees that, no matter your requirements, we have a solution for you.

The D825 and D925 rotary lobe truck blowers are some of the most durable and versatile in the industry. Fitting a D825/D925 on your tractor means it will be ready to do any job necessary. Ideal for pneumatic conveying applications such as:

- Cement
- Sand
- Fly ash
- Flour
- Sugar
- Grain
- Pebble lime
- Plastic pellets

Positive Displacement Blower

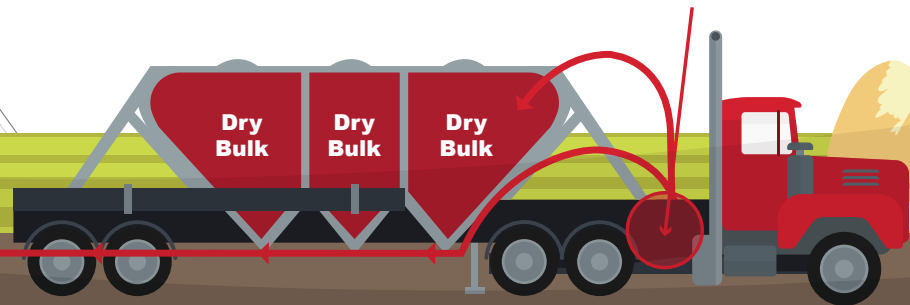
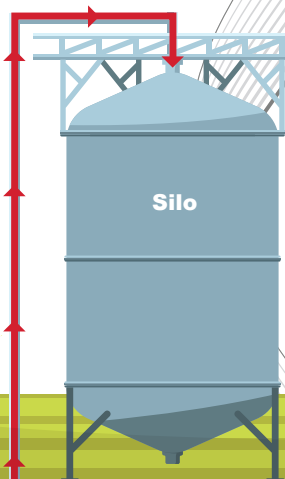

D825 & D925 DELIVERY

Model	Flow Rate CFM	Pressure PSIG, CONTINUOUS	Vacuum inHg
D825	1000	20	17
D925	1340	19	17

Maximum flow and pressure listed. Actual performance may vary based on system design, environment, and maintenance.

Features

- Up to 20 psig continuous duty pressure rating on the D825, and an improved 19 psig continuous pressure rating on the D925.
- Diamond port design greatly reducing noise and airflow pulsations.
- Oil lubrication at both ends reducing bearing temperature and eliminates the need for greasing.
- Efficient bi-lobe rotors for cooler operation.
- Twin drive shaft offers bi-directional rotation and ensures correct alignment of drive shaft upon installation.
- Heat dissipation ribbing of the body, end plates and gear cases for cooler discharge temperatures and allows for tighter tolerances.
- PTO (Direct), belt or hydraulic drive options.
- Simple installation with Gardner Denver's mounting kit and accessories.
- Packaged units available for on-site product transfer requirements and local support through Gardner Denver's dedicated distributor network.
- 12/18 months warranty

Over Temperature & Over Pressure Protection

- Melt plugs relieve 4-6 psi along with significant drop in temperature.
- One plug fitted on the suction side and one on the discharge side.
- Reduces the probability of accidental overheating.
- Consistent release of temperature from each plug.
- Visual activation indicator.

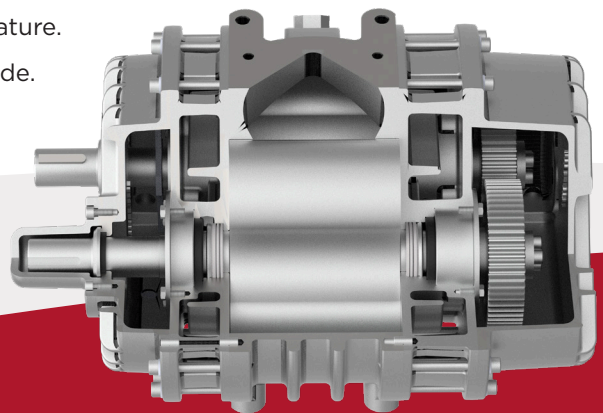
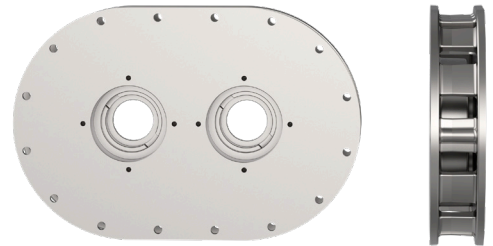

Rotary Vane Compressors

HPD450 & E490

- Coolest operating temperatures in the industry
- Quietest blower in the industry
- Lightest blower in its class
- Most energy efficient truck blower in its class—44 hp delivers 325 cfm and 25 psi
- Capable of medium-high pressure off-loads
- Lower initial cost (no discharge silencer required)
- Ideal for lease operators

"It's one of a kind."

The eco-friendly oil-free rotary vane compressors are used for a variety of applications, including:

- Pulverized limestone
- Clay
- Hydrated lime
- Barite
- Parlite
- Plastic pellets
- Dry bulk chemicals
- Calcium carbonate
- Cement
- Sand
- Fly ash
- Starch
- Sugar
- Grain
- Flour



HPD450 & E490 DELIVERY

Model	Flow Rate CFM	Pressure PSIG, CONTINUOUS
HPD450	370	25
E490	370	30

Maximum flow and pressure listed. Actual performance may vary based on system design, environment, and maintenance.

*“The fastest off-load
times in the business.”*



“Delivering”
since 1987

Model HPD450

Location Is Everything



Hydraulic Drive D825

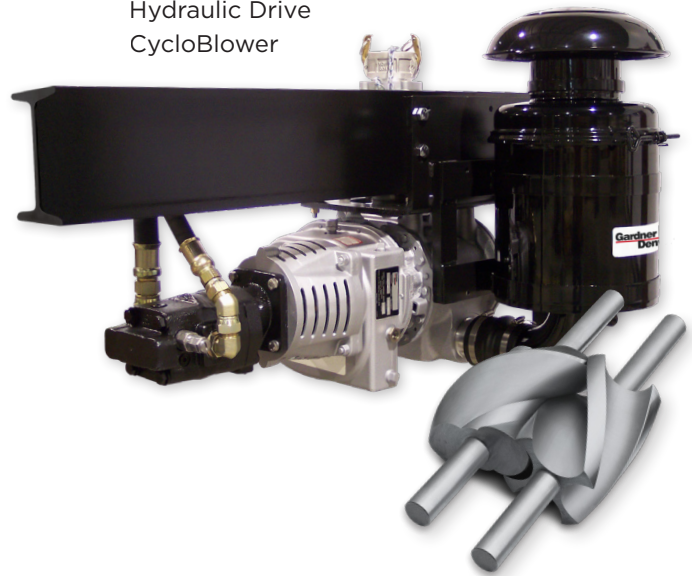

Hydraulic Drive CycloBlower

Hydraulically Driven Blower Systems

Designed and engineered with the importance of location in mind, Gardner Denver hydraulically driven blowers offer the flexibility to meet your placement needs.



The modern tractor is more crowded than ever before making direct coupling to a PTO more and more difficult. Driving your blower system hydraulically affords you the flexibility to mount your blower in multiple locations, allowing you to maximize your space and improve your access to equipment.

Hydrapak Coolers



MHX



MH5

“Always cool under pressure.”
“The original hydraulic cooler.”

- Robust stainless steel construction
- Eliminates excess weight caused by heavy reservoir
- Minimizes maintenance cost and spill risks
- Delivers highest flow ratings in its class
- Appropriate for:
 - CycloBlower
 - CycloSaver
 - D825
 - HPD450
 - Product pumps

The Hydrapak Story

- 1983—1 EH Series first developed in the U.K.
- 1988—Hydrapak redesigned for US market; named DH Series
- 1997—MH Series developed to include:
 - Improved cooling capacity
 - More compact design
- 2006—MH5 released
 - Flow rate up to 60 gpm
 - Highest heat rejection rate of any mobile cooler in the industry
- 2022—MHX released

HYDRAPAK DELIVERY

Model	Pressure PSI	Weight LBS	Reservoir Size GALLONS	Flow Rate GPM	HP Cooled HEATED @ 80° ΔT
MH1	3000	45	2	20	8
MHX*	up to 5000	90	3.4	30	15.2
MH3	3500	75	4	40	17
MH5	3500	94	4.4	60	28

Maximum flow and pressure listed. Actual performance may vary based on system design, environment, and maintenance.

*Weight for 2500-3500 PSI units.

Factory Certified Remanufactured Equipment



Manufacturer Quality Assurance

Our remanufacturing facility at Sedalia, Missouri is dedicated to the production of remanufactured blowers. This dedication assures a level of expertise and attention to detail in the remanufacturing process that is unmatched anywhere else.

Complete Inspection

We use the latest technology to analyze and inspect units. This ensures that any unit is brought back to Gardner Denver's original manufacturing specifications to deliver the performance you require.

Extensive Testing

Every remanufactured blower has to pass the same tests as a new machine. This guarantees that all remanufactured products operate to Gardner Denver specifications for performance and reliability.

Full Warranty

All remanufactured blowers offer a complete warranty providing coverage 12 months from the date of installation or 18 months from the date of shipment, whichever occurs first.

Available Models

- CycloBlower Transport Series

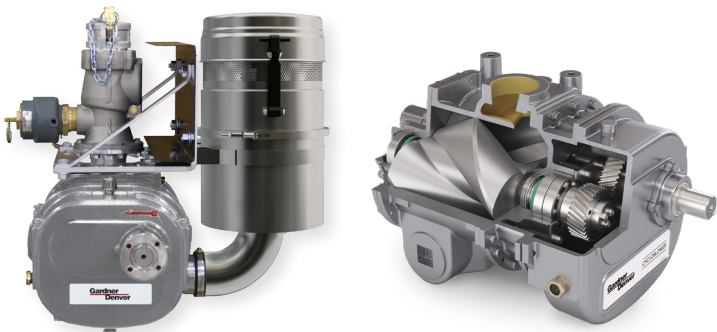

CycloBlower

Parts, Accessories & Service

All genuine Gardner Denver parts are factory engineered to meet the exact specifications of our machines. Only the highest quality components designed explicitly for our equipment are used. This provides the reliability to allow you to do your job with confidence.

“All parts are not created equal.”

Truck Blower Overhaul Kits

Gardner Denver certified kits use only factory-specified, original parts insuring “like-new” performance.

GD Inlet Filters

- Designed to withstand the heavy punishment of over-the-road operation
- Available in carbon-steel and stainless-steel

Relief Valves

- Discharge fittings available in 2” line size
- Discharge check valves available
- Kits include: check valve, relief valve and camlock complete with dust cap

Genuine GD Lubricants

Gardner Denver synthetic lubricants are formulated specifically to maximize machine performance and longevity.

Service Commitment

- Gardner Denver is proud to have a vast network of factory-trained and certified distributors.
- This provides 24/7 local service support and a level of expertise that is unmatched and offers you peace of mind.



Stainless Steel Filter



Relief Valve





Gardner Denver®

www.GardnerDenver.com

©2026 Industrial Technologies and Services, LLC
Printed in U.S.A.
GDT-DRY-BULK 7th Ed. 6/26



Please recycle after use.