

GHH RAND®

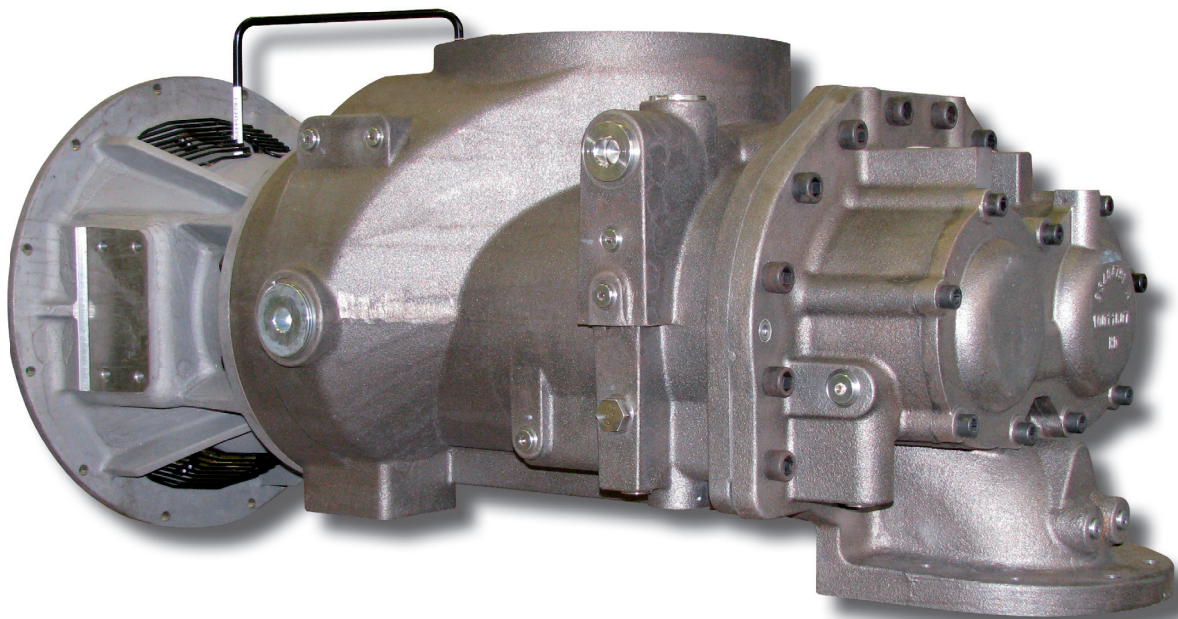

CE177G – Screw compressor for industrial and portable applications



GHH RAND recommends:



- Maximise life and efficiency with Primecool lubricant
- Ask your sales rep. for details

GHH RAND®

CE177G – Screw compressor for industrial and portable applications

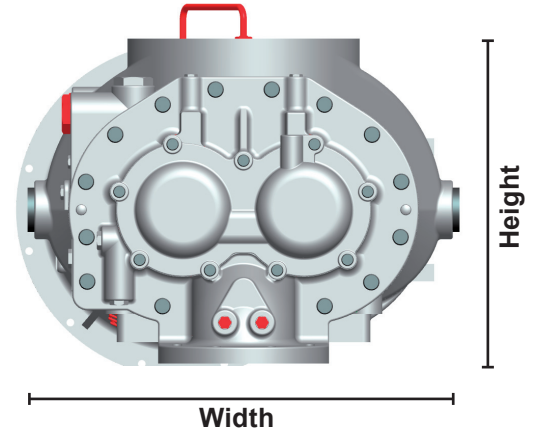
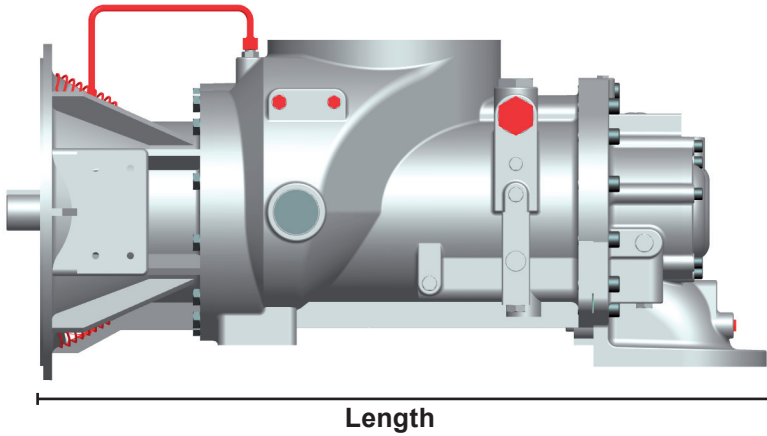

Technical data

	Units	CE177G
Type of drive		Electric motor or Diesel engine
Volume flow	m ³ /min	13.1–36.4
Outlet pressure (min./max.)	bar(a)	6,0 / 14,0
Motor rating	kW	60–200
Length x Width x Height	mm	1.050 x 650 x 490
Weight	kg	565
Inlet flange	DIN EN 1092	DN 200
Outlet flange	DIN EN 1092	DN 125
Oil connection	ISO 6149-1	M42 x 2,0
Instrument port at inlet	DIN EN 837-1	M14 x 1,5 M12 x 1,5
Instrument port at outlet	DIN EN 837-1	2 x M12 x 1,5
Vibration measurement		3 x SPM
Gear sets		0.845, 0.945, 1.058, 1.14, 1.277, 1.432, 1.548

Medium: Air, Inlet temp. 20°C/68°F, Discharge temp. 80°C/176°F, Inlet pressure 1 bar(a)/14.5 psi(a), RH: 60%

Advantages

- Gear drive flexibility between 60–200 kW
- Drive flexibility (7 standard gear ratios)
- Reduced maintenance with robust engineered bearing systems

Highlights

- Low specific power consumption due to optimised volume ratio
- Flow loss optimised connections
- Flanged housing provides ease of alignment
- Flow controlled duct results in lower sound levels
- Long operating life (mechanical seal)
- Easy snap on due to standard SAE connection

Ease of installation

- DIN flanges
- Ease of assembly with integrated instrument connections (Inlet & discharge)
- Single oil point connection with integrated tubing
- Cylindrical drive shaft with fit in key
- O-Ring sealing (easy to maintain)
- Standard components, everywhere available

GHH RAND Schraubenkompressoren GmbH
Max-Planck-Ring 27 • 46049 Oberhausen • Germany
Phone +49 (0) 208 9994-0 • Fax +49 (0) 208 9994-111
industrial-sales@ghhrrand.com • www.ghhrrand.com

