



An Ingersoll Rand Business

COMPRESSORS & SYSTEMS FOR THE

CHEMICAL & PETROCHEMICAL Industry





Proven Solutions. Unparalleled Expertise.

DELIVERING ROBUST & RELIABLE COMPRESSORS SINCE 1947.

For more than 70 years, Garo has been a global leader in liquid ring technology, providing:

- **Reliable compressors and systems** to the global Chemical & Petrochemical industry
- **Customized solutions** designed to meet unique project specifications and customer requirements
- **GARO Service & Support** built to deliver immediate solutions

Manufacturing compressors is the core of what we do, and assisting clients is our vocation. From the very first steps, we guide you to select the right equipment, system and solution for your process application.



GARO® Liquid Ring Technology for Chemical & Petrochemical Applications

GARO offers reliable liquid ring compressors and systems for the most demanding chemical & petrochemical applications. Not only are we highly specialized and experienced in the most challenging applications, we are the undisputed leaders in high discharge pressure. We have proven experience in dealing efficiently with pressures up to 12 bar g (174 psig).

- Highest Reliability-Design Life of 40+ Years
- Reduced Maintenance - no internal lubricant required
- Wear-free Performance - no metal to metal contact
- Minimal process upset - handles carryover even in severe applications
- Cool running - ideal for handling corrosive gases, and other temperature-sensitive applications
- Near to isothermal compression
- Low maintenance and easy to service with an overhung impeller design Inherently safe
- Low working speed
- Low vibration and noise
- Oil-free service
- Available in standard and exotic materials

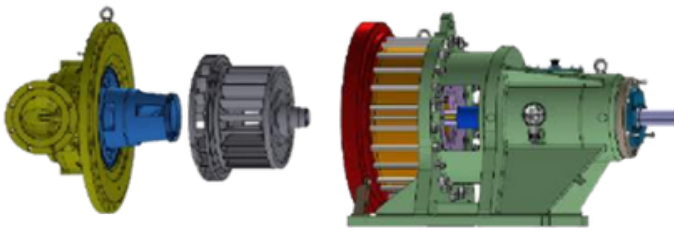

Overhung Impeller Design

Liquid Ring Working Principles

Seal liquid is fed into the machine and, by centrifugal acceleration, forms a moving cylindrical ring, which takes the shape of the double lobe eccentric casing.

This liquid ring creates a series of seals in the space between the impeller vanes forming compression chambers. The gas is fed into the machine by a distribution cone. Gas compression is achieved by the rotation of the impeller inside the seal liquid.

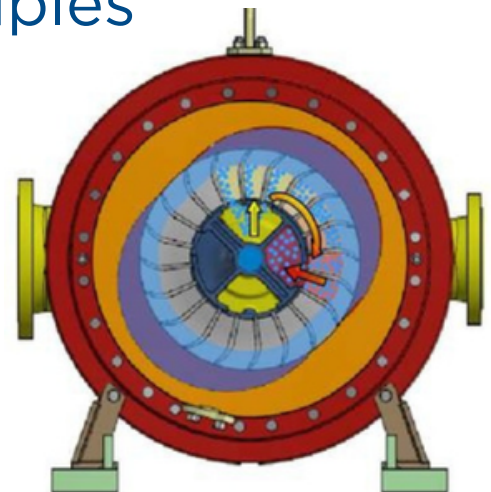

QUALITY SUSTAINABLE SOLUTIONS

GARO is committed to providing sustainable solutions that help your company comply with safety and environmental regulations while lowering total cost of ownership. Our products and systems reduce resource consumption, while operating reliably with minimal maintenance requirements. Together we build more sustainable and profitable chemical & petrochemical production.

SPECS COMPLIANT

GARO products comply with specific customer requirements and International Standards. The isothermal compression characteristic of our compressors enable GARO products to minimize material corrosion.

ISO CERTIFICATION

In our ongoing effort to provide quality, sustainable solutions, our manufacturing & service facilities are ISO 9001:2015, ISO 14001:2015, and OHSAS 18001 certified.

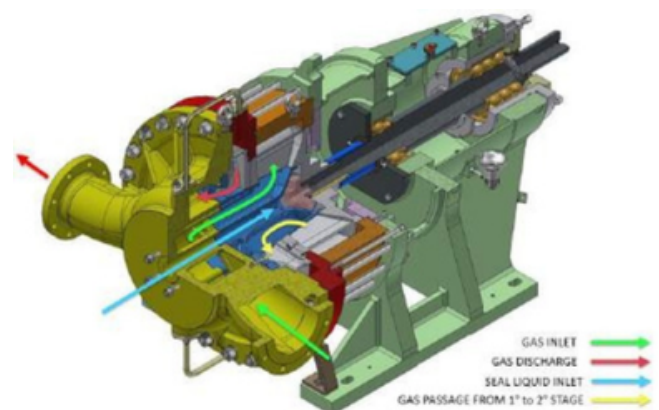

CHEMICAL & PETROCHEMICAL Application Expertise

Unlike any other technologies, GARO systems can handle moisture-laden inlet streams; explosive gasses, and dirty, abrasive or corrosive gas mixtures. Some of these gasses include:

- Acetone
- Acids
- Ammonia
- Benzene
- BTX
- Butadiene
- Carbon Dioxide
- Dry Chlorine
- Ethylene
- Ethylene Dichloride
- Hexane
- Hydrocarbons
- Hydrogen Chloride
- Hydrogen Peroxide
- Hydrogen Sulfide
- Nitrous Oxides
- Propylene Oxides
- Steamer Off Gas (HDPE, LDPE, PP)
- Styrene Sulfur
- Dioxide Vinyl Chloride
- Monomer Vent
- Gas Wet Chlorine

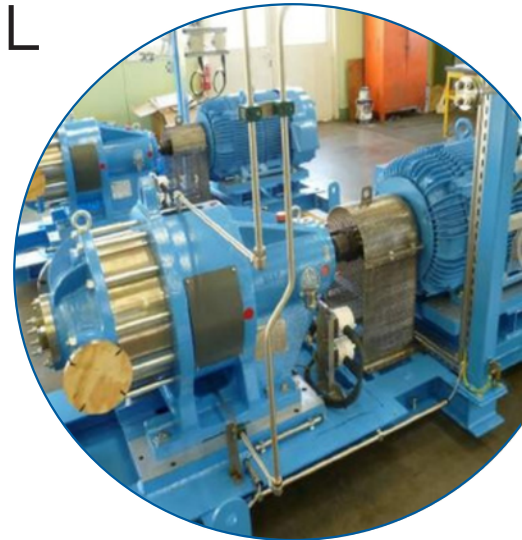

GARO® Liquid Ring Compressors for Corrosive Gas Applications

Typical arrangement for handling chemical and petrochemical process gases:

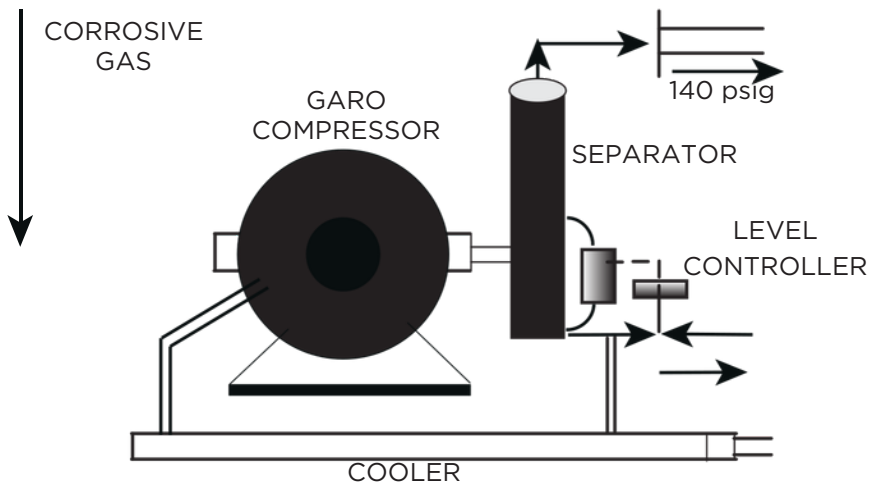

GARO® Liquid Ring Solutions for Chlorine Applications



DRY CHLORINE

GARO liquid ring compressors deliver robust, reliable and proven solutions for the Chemical industry, especially during the Dry Chlorine treatment. Thanks to the isothermal compression and the use of sulphuric acid as seal liquid, GARO products help to obtain full chlorine dehydration.

WET CHLORINE

With GARO solutions, the chlorine gas remains constantly water saturated and at constant and controlled temperature. Garo provides solid Titanium made compressors and pumps to fulfill the application and project specific requirements. GARO liquid ring vacuum pumps are the perfect solution for Brine Dechlorination, to remove chlorine gas, physically absorbed in depleted brine, by using mild vacuum process.

IN BOTH APPLICATIONS

Thanks to the particular design, Garo compressors can handle wet & dry chlorine without any problem and they are unaffected by solids carry over, scrubbing all the powders and impurities carried by the feed gas. The liquid ring action delivers the gas in very clean conditions. Garo systems can easily be adapted for remote control operation (DCS), working on continuous service without the presence of any operator on the plant.

HAVING SUPPLIED **MORE THAN 500 COMPRESSORS** FOR CHLORINE APPLICATIONS OVER THE LAST 20 YEARS, GARO IS A **REAL EXPERT** IN DEALING WITH CHLORINE.

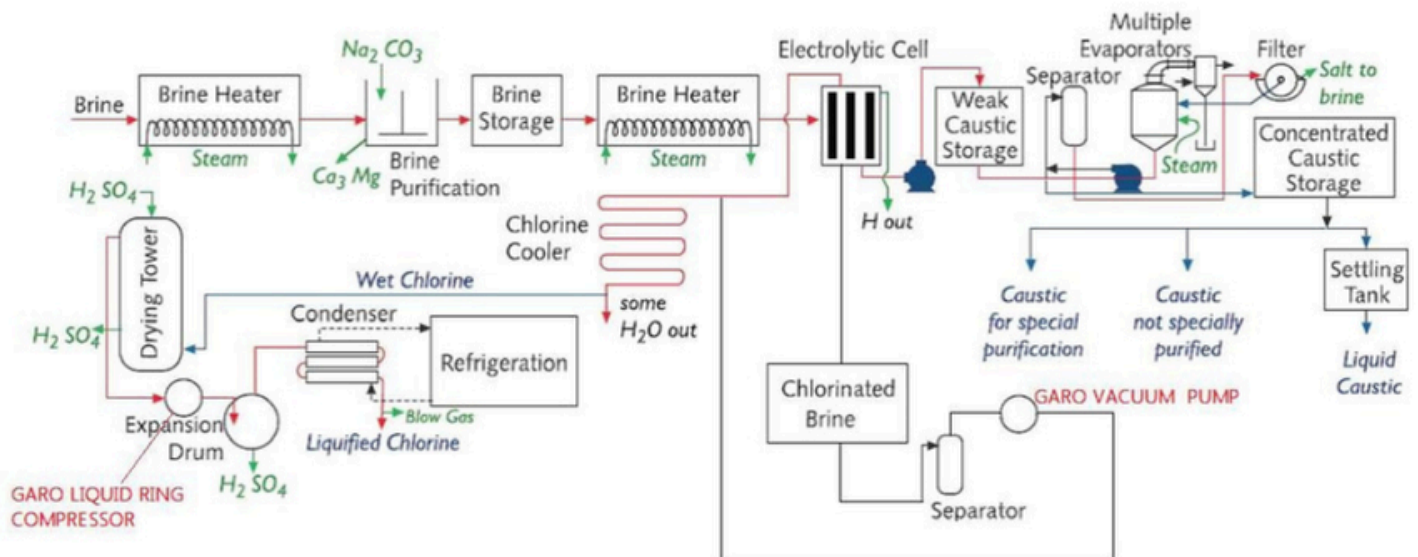

GARO® Liquid Ring Compressors for VCM Application



In modern PVC production plants liquid ring compressors work as strippers for the Vinyl Chloride gases, which are entirely recovered to be reintegrated in the production cycle. GARO VCM compressors are reliable and efficient machines, provided in both single and double stage versions according to process pressure requirements.

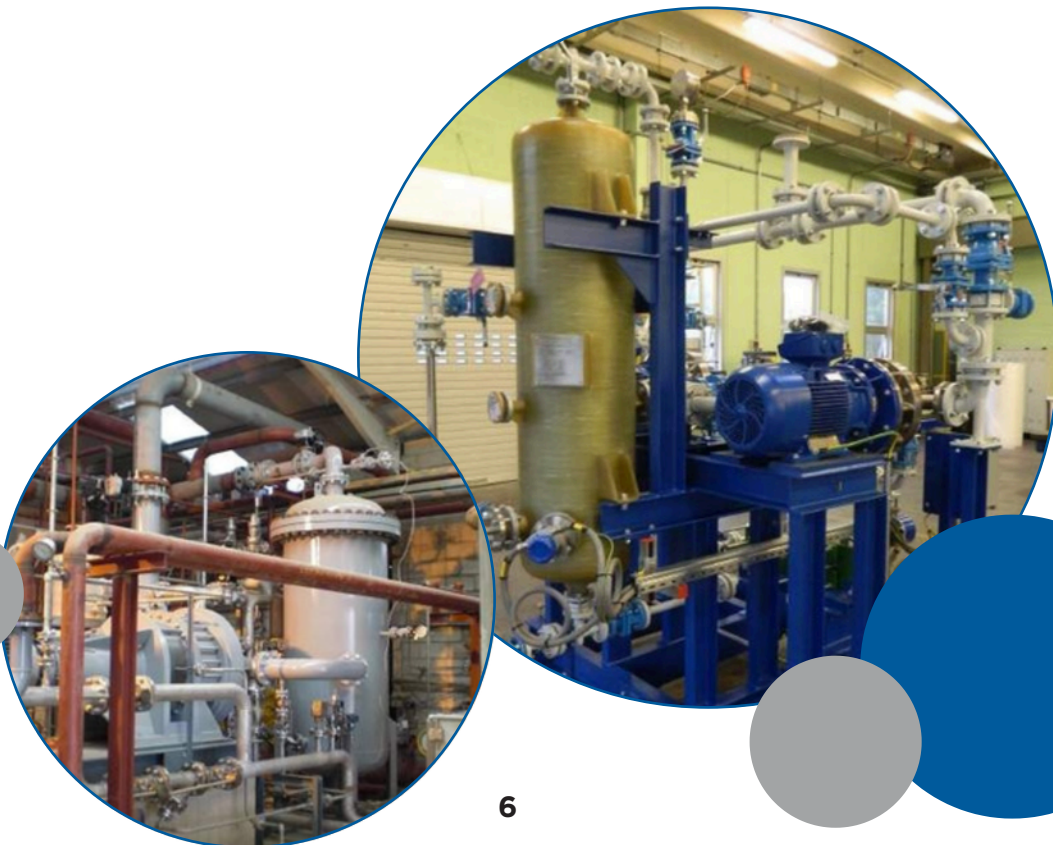
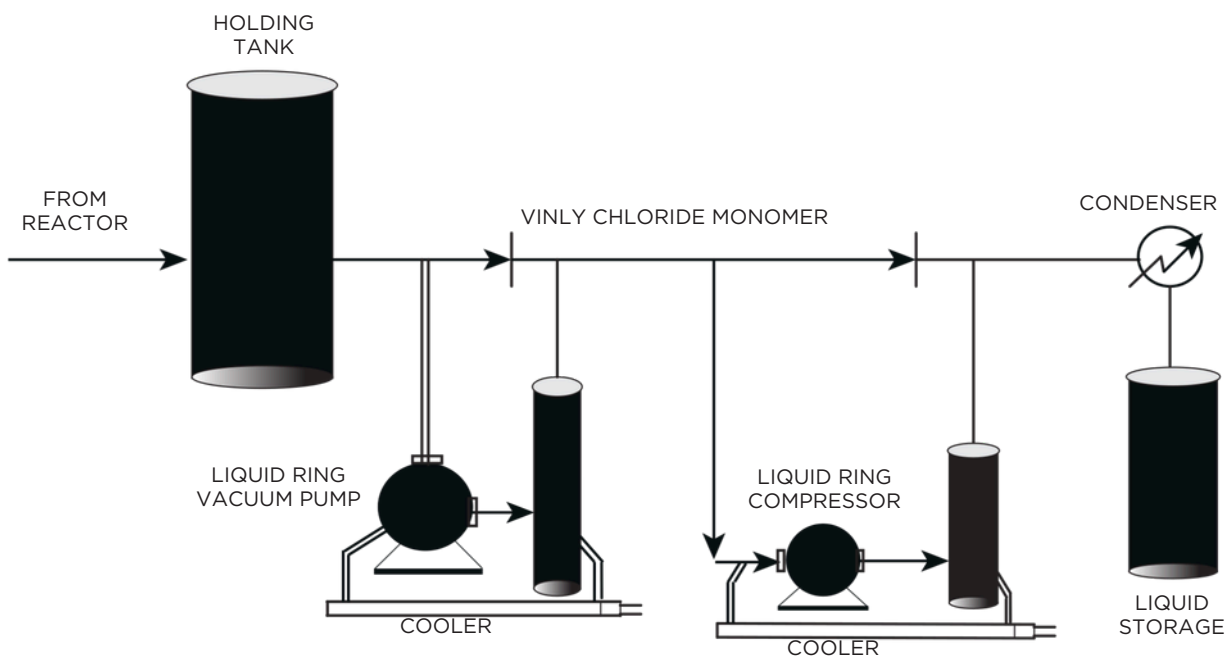

GARO® Customized & Packaged Solutions

Founded as a liquid ring compressor manufacturer in 1947, we quickly became experts in the engineering, configuration and design of custom, packaged solutions. Every day we use our extensive knowledge of liquid ring technology to support customers throughout every step of the project: from the concept/FEED study to the start-up of the system. We also provide customer care and assistance on the long term basis through our global network of GARO CERTIFIED™ Service & Support.



1. From the concept & FEED study, we provide estimates and possible process reevaluation to help end-users and consultancy companies to choose the right technology.



5. Before the products leave our facility, we take all necessary factory tests.



2. During the project definition with EPC, we sustain the clients in the choice and comprehension of the best solutions. We are not suppliers; we are part of your team.



6. GARO Service & Support not only takes care of the erection, commissioning and start-up of the system, but also trains the customer how to run the package.



3. In the detailed engineering phase, our qualified engineers design customized systems based on project requirements, to create a unique product.



7. We never forget our customers after the sale phase: guarantees and warranties are always provided. GARO Service & Support is always ready to help you to protect your investment by maintaining performance and reliability.



4. We take care of the package manufacturing choosing only the best suppliers and providing scrupulous quality controls.



Garó Products & Systems



GARÓ® Liquid Ring Compressors

GARÓ Liquid Ring Compressors are ideal for demanding process applications in petroleum refining and chemical plants and reach pressures up to 12 bar g abs (174 psig).



GARÓ® Centrifugal Compressors

GARÓ Centrifugal Compressors are custom designed for special applications for handling critical gases. GARÓ Centrifugal Compressors reach pressures from 1.0 up to 12.0 bar g.



GARÓ® Packaged Solutions

Every industry has unique challenges - and Garó is ready to solve them. Our customized package solutions offer complete systems designs, built around reliable GARÓ liquid ring technology.



GARÓ® Service & Support

Our team of factory-trained technicians, global service centers, and available inventory of OEM parts are available to restore performance and efficiency.



An Ingersoll Rand Business

Strada Provinciale Cassanese, 108
20052, Vignate (MI)

www.garocompressors.com

GDG-CHEM-1169 1st Ed. 05/18

 Please recycle after use.