



47143292
Edition 3
January 2022

Air Impulse Wrench (Twin Blade)

Model 500A and 700A

Parts Information



Save These Instructions

IR *Ingersoll Rand*[®]

Models 500A and 700A, Air Impulse Wrench (Twin Blade) - Exploded View

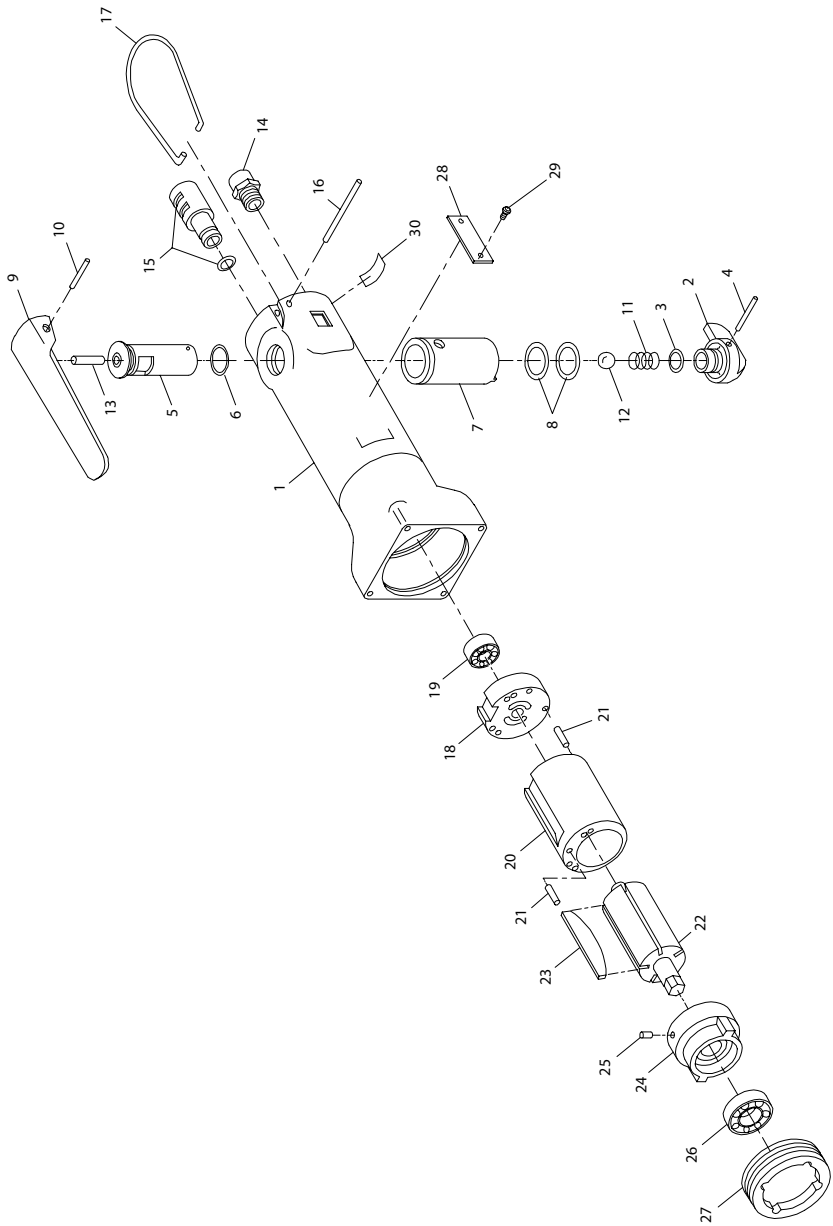

(Dwg. TPB959)

Models 500A and 700A, Air Impulse Wrench (Twin Blade) - Parts List

Item	Parts Description	Part Number	Item	Parts Description	Part Number
	Motor Housing Assembly		31	Liner case	
	for Model 500A	500A-A40		for Model 700A	700A-240
	for Model 700A	700A-40		Liner Case Assembly	
1	Motor Housing		for Model 500A	500A-A240	
	for Model 500A	500A-40	32	Liner Case	
	for Model 700A	700A-40		for Model 500A	500A-240
2	Reverse Valve Knob Assembly	EQ1065-658		33	Torque Adjustment Screw
3	Reverse Valve Knob Seal	EQ1065-119	for Model 500A		700A-230
4	Knob Retaining Pin	EQ1065-152	34	Torque Adjustment Plug Lock (2)	
5	Reserve Valve Assembly	180PQ-A329		for Model 500A	180PQ-283
6	Reserve Valve Seal	180PQ-67	35	Plug Lock Spring	
7	Reserve Valve Bushing	700A-330		for Model 500A	180PQ-219
8	Reserve Valve Bushing Seal (2)	EQ106P-283	36	Plug Lock Screw	
9	Throttle lever	EQ106P-273		for Model 500A	500A-230
10	Throttle Lever Pin	EQ106S-120	37	Liner O-Ring	
11	Throttle Valve Spring	EQ106S-51		for Model 500A	EQ208-237
12	Throttle Ball	180PQ-929	38	Housing Cap	
13	Throttle Plunger	180SQ-A23		for Model 500A	380PQ-A212
14	Inlet bushing	EQ106S-565		for Model 700A	EQ208S-237
15	Exhaust Deflector Assembly	180PQ-A23	39	Rear Liner Cover	
16	Deflector Retaining pin	EQ106P-152		for Model 700A	EQ208S-212
17	Suspension Bail	EQ106S-365		Rear Liner Cover Assembly	
	Motor Assembly		for Model 500A	380PQ-A212	
	for Model 500A	500A-A53	40	Liner Cover O-Ring	
	for Model 700A	700A-A3		for Model 500A	EQ106S-236
18	Rear End Plate Assembly	380SQ-A12	41	Liner Cover O-Ring	
19	Rear Rotor Bearing	500A-22		for Model 500A	EQ106S-236
20	Cylinder Assembly			for Model 700A	EQ208S-237
	for Model 500A	500A-A3	42	Liner Assembly	
	for Model 700A	700A-53		for Model 500A	500A-A203
	21	Cylinder Alignment Pin (2)			for Model 700A
	for Model 500A	500A-299	43	Liner pin (4)	
	for Model 700A	EQ112P-99		for Model 500A	18PQ-298
	22	Rotor			for Model 700A
	for Model 500A	500A-22	44	Relief Valve	
	for Model 700A	EQ108S-53		for Model 500A	500A-222
	23	Vane Packet (Set of 6 Vanes)			for Model 700A
	for Model 500A	500A-42-6	---	Spring Guide Assembly	
	for Model 700A	EQ106S-42-6		for Model 500A (1)	500A-A255
	24	Front End Plate Assembly			for Model 700A (2)
	for Model 500A	500A-A11	45	Spring Guide	
	for Model 700A	700A-A11		for Model 500A	500A-255
	25	Front End Plate Alignment Pin (2)		380SQ-298	for Model 700A
26	Front Rotor Bearing		46	Spring Guide Seal	
	for Model 500A	500P-22		for Model 500A	180PQ-272
	for Model 700A	EQ106S-22		for Model 700A	EQ106P-288
27	Front End Plate Spacer	700A-41	47	Guide Assist Spring	
28	Nameplate		48	Drive Shaft	
	for Model 500A	500A-301		for Model 700A	EQ212P-288
	for Model 700A	700A-301		for Model 500A	500A-626X
	for Model 500A-EU	500A-EU-301		for Model 700A	700A-626X
	for Model 700A-EU	700A-EU-301		49	Blade (2)
29	Nameplate Drive Screw (2)	EQ106S-322	for Model 700A		700P53-220
30	Oil daily Label	500P-69	---	Blade Assembly	
	* Motor Tune Up Kit (Includes illustrated item 19,23 and 26)			for Model 500A	500A-A220
		for Model 500A		500A-K500	49
	for Model 700A	700A-K500	50	Balde Assembly Pin (2/Assembly)	
	Impulse unit Drive Assembly			for Model 500A	500A-120
	for Model 500A	500A-A200		51	Blade Spring (2)
for Model 700A	700A-A200	for Model 500A	380PQ-568		
				for Model 700A	EQ208S-219

Models 500A and 700A, Air Impulse Wrench (Twin Blade) - Exploded View

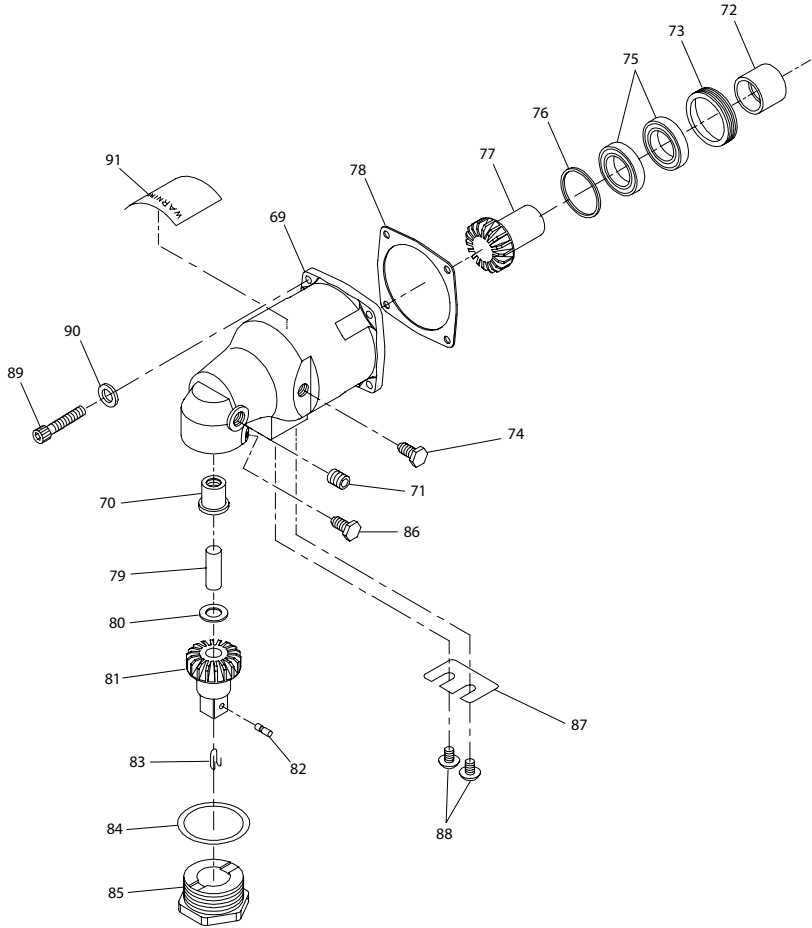

(Dwg. TPB959)

Models 500A and 700A, Air Impulse Wrench (Twin Blade) - Parts List

Item	Parts Description	Part Number	Item	Parts Description	Part Number
52	Drive Shaft Seal		---	Angle Housing Assembly	
	for Model 500A	180PQ-271		for Model 500A	500A-A727
	for Model 700A	EQ22085-271		for Model 700A	700A-A727
53	Seal back-Up Ring		69	Angle Housing	
	for Model 500A	380PQ-272		for Model 500A	500A-727
	for Model 700A	EQ1065-272	70	Spindle shaft Bushing	700A-641
54	Front Liner Cover Assembly		71	Gear Plug	180PQ-95
	for Model 500A	380PQ-A211	72	Angle housing Spacer	
55	Liner Cove Pin	180PQ-232		for Model 500A	500A-900
---	Front Liner Cover Assembly			for Model 700A	700A-900
	for Model 700A	700A-A211	73	Pinion Bearing Cap	700A-902
56	Front Cover Plate Assembly		74	Bearing Cap Retaining Screw	700A-277
	for Model 700A	700A-B211	75	Pinion Bearing (2)	EQ1065-22
57	Torque Adjustment Screw		76	Pinion Bearing Shim	
	for Model 700A	700A-230		0.004" (0.1 mm Thickness)	700A-740
58	Adjusting Screw Lock			0.008" (0.2 mm Thickness)	700A-741
	for Model 700A	500PQ-288	0.012" (0.3 mm Thickness)	700A-742	
59	Oil Plug		77	Bevel Pinion	700A-901
	for Model 700A	EQ1065-277	78	Housing Gasket	500A-746
60	Oil Plug Seal		79	Spindle Shaft	500A-298
	for Model 700A	EQ1065-228	80	Spindle Upper Shim	
61	Oil Seal Support			0.012" (0.3mm Thickness)	500A-933
	for Model 700A	EQ1065-229		0.024" (0.6mm Thickness)	700A-933
62	Front Liner Cover Guide Seal (2)		---	Spindle Assembly	700A-A626
	for Model 700A	EQ2085-238	81	Spindle	700A-626
63	Oil Plug		82	Socket Retaining Ring	5020-716
	for Model 500A	180PQ-277	83	Retaining Pin Spring	401-718
64	Oil Plug Seal		84	Spindle Lower Shim	
	for Model 500A	EQ110P-288		0.004" (0.1 mm Thickness)	700A-743
65	Oil Stop Cap Assembly			0.008" (0.2 mm Thickness)	700A-744
	for Model 500A	EQ106P-A38	0.012" (0.3 mm Thickness)	700A-745	
66	Stop Cap O-Ring		85	Spindle Cap	700A-728
	for Model 500A	EQ106P-288	86	Spindle Cap Retaining Screw	700A-277
67	Back Up Ring		87	Torque Adjustment Screw Cover Plate	700A-888
	for Model 500A	380SQ-272	88	Cover Plate Mounting Screw (2)	500A-322
68	Front Liner Seal		89	Angle Housing Mounting Screw (4)	
	for Model 500A (1)	380PQ-288		for 500A Model	500A-638
	for Model 700A (2)	EQ2085-236	for 700A Model	500PQ-638	
*	Impulse Mechanism Tune Up Kit (for Model 500A)		90	Mounting Screw Lock Washer (4)	500P-58
	Includes illustrated items 34(2), 37, 40, 41, 46, 52, 53,64 and 68(2)	500P-K600	91	Warning Label	
* Impulse Mechanism Tune Up Kit (for Model 700A)		for 500A and 700A Model		WARNING-2-99	
	Includes illustrated items 41, 46, 52, 53, 60, 61 62(2) and 68(2)	700A-K600		for 500A-EU and 700A-EU Model	EU-99
*	Fluid replacement Kit		EQ1065-K400	EQ1065-K400-1	
	Includes Fluid Syringe, Fill Tube and 4 oz. (31 ml) of replacement Fluid				
*	Tool kit				
	(Includes all specialized tooling required to repair these tools and consist of two Spanner plugs, a tee wrench with a special tip, an O-Ring installer Fixture and a pressing fixture that has a Disassembly arbor and a Pressing Sleeve)				
	for 500A Model	180PQ-99			
	for 700A Model	700A-99			

* Indicates not Illustrated

Parts and Maintenance

When tool life has expired, it is recommended that the tool be disassembled, degreased and parts separated by material for proper recycling.

Tool repair and maintenance should only be carried out by an authorized Service Center.

Refer all communications to the nearest **Ingersoll Rand** office or distributor.

Related Documentation

Manuals can be downloaded from ingersollrand.com

For additional information, refer to:

Product Safety Information Manual 04584983

Product Information Manual 47133053

Maintenance Information Manual 47143300

