



An Ingersoll Rand Business

A photograph of an industrial flare gas recovery system. The scene is dominated by several tall, cylindrical distillation columns and a complex network of pipes and metal walkways. The sky is a mix of orange and blue, suggesting a sunset or sunrise. The overall atmosphere is industrial and technical.

**LIQUID RING  
COMPRESSORS  
FOR FLARE GAS  
RECOVERY**

# TABLE OF CONTENT

---

Gas Flaring Overview

Garo Liquid Ring  
Compressors Benefits

How Does The Flaring Process  
Work?

GARO® Customized &  
Packaged Solutions for EPC  
Companies

Garo Concepts

Garo Products and Applications

Contacts



# Gas Flaring Overview

---

## **Rising Global Energy Needs and the Environmental Impact of Flaring**

Population growth and an **improvement in living standards**, particularly in developing countries, have significantly increased the demand for energy worldwide.

To meet this demand, the production of oil and gas has expanded across the upstream, midstream, and downstream sectors.

However, **every crude oil well produced contains associated gas dissolved in the liquid, which must be separated from the liquids through a series of gas/liquid separators.**

The midstream process stabilizes the crude and light condensate for transportation, while refining the gas for commercial sale as fuel.

*Though upstream, midstream, and downstream facilities all have flares that safely and efficiently dispose of waste gases generated, combustion of volatile organic compounds (VOCs) results in the production of carbon monoxide (CO), carbon dioxide (CO<sub>2</sub>), nitrogen oxides (NO<sub>x</sub>), and potentially sulfur oxides (SO<sub>x</sub>). Moreover, flaring processes release VOCs into the atmosphere, which can contribute to climate change and other environmental issues.*

Flares are critical safety devices used **to prevent the release of unburned VOCs into the atmosphere, safeguarding plants** against excessive pressure build-up from routine operations, gases, vapors, or process upsets, startups, and shutdowns.

Multiple flares may be used to handle various sources of waste gas, with the flare gas composition varying from one network to another.

**Flare gas recovery (FGR) systems are designed to recover flows generated during normal plant operations**, including purge gas, sweep gas, vent gas, valve leaks, and equipment depressurization for maintenance.

# Gas Flaring Overview

---



## Understanding and Utilizing Flare Gas Recovery Systems

**Flare Gas Recovery (FGR) systems are specifically designed to capture waste gases that would normally be directed to the flare tip during regular plant operations.**

By intercepting and salvaging waste gases upstream of the flare, FGR systems can recover a portion or the entirety of the gas before it is flared.

Since most flares operate at pressures slightly above atmospheric pressure, **the gas must be compressed to a higher pressure to transport within the plant and for intended usage.**

**Employing an FGR system offers several potential advantages, including using flare gas as a fuel source within the plant, reducing the need for purchased fuel.**

Additionally, **FGR systems reduce the continuous burning of vapor/gas in the flare, leading to a decrease in the utilities required for flare operation** and a reduction in associated smoke, thermal radiation, noise, and pollutant emissions. FGR systems can also extend the operational life of the flare tip.

It's worth noting that flare gas recovery systems are not typically designed to handle emergency flare loads. In some cases, **the system is only dimensioned to handle the normal flare rate, above which excess gas is flared.**

Since actual loads on these systems vary widely, they must be designed to accommodate a broad range of dynamically changing loads. In certain instances, **flare gas recovery systems are installed to adhere to local regulatory constraints on flare operations**, which dictate the sizing of the system to comply with such limitations.



# How Does The Flaring Process Work?

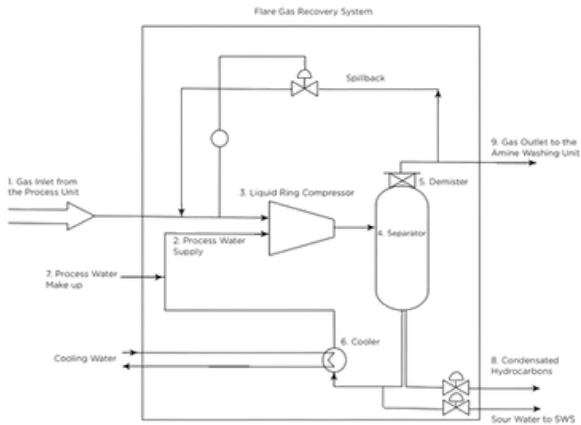

## A Closer Look at the Gas Stream Process

The gas stream (1) that originates from the flare Process Unit is combined with process water (3) and introduced into the Liquid Ring Compressor (2).

After the compression phase, the mixture of gas, water, and hydrocarbons moves on to the separator (4), where the three components undergo separation.

The gas passes through a demister (5) to minimize water content before exiting the vessel from the upper section. The condensed hydrocarbons and water are naturally separated due to the reduced gas velocity.

The water is cooled by a heat exchanger (6) and redirected to the compressor, while a continuous supply of process water (7) is integrated into the compressor suction line to ensure a consistent water ring within the compressor.

The condensed hydrocarbons are discharged (8). The gas that emerges from the separator is then sent to the Flare Gas Amine Scrubbing Unit (9) for amine treatment aimed at H<sub>2</sub>S removal. The treated gas is subsequently directed to the Fuel Gas header and utilized as a fuel source.

# GARCO Concepts

## The Power of Garco Liquid Ring Technology

At Garco, we understand the significance of rugged, reliable design. Our liquid ring compressors epitomize this commitment by exceeding industry standards. **Optimal Balance and Maintenance Efficiency** Our secret weapon? The Casing with Double Eccentricity. It empowers our compressors to strike the perfect balance, minimizing radial forces on the rotor. **Maintenance Simplified** The Overhung Impeller design reduces maintenance requirements to a minimum. With just one mechanical seal, we've managed to cut down maintenance needs and save you precious time. **Elegance in Simplicity** Garco Liquid Ring Compressors are designed with a straightforward layout and minimal mechanical parts. This simplicity translates to reduced downtime and smoother operations.



---

## Place your trust in the expertise of Garco, the specialists in Flare Gas Recovery Systems

With over 200 flare gas recovery systems installed across the globe, Garco possesses the knowledge and experience to optimize oil and gas plant operations while minimizing their environmental impact.

GARCO's implementation of liquid ring compressor systems in flare gas recovery applications dates back to 1986. There are several notable benefits to employing liquid ring compression in flare gas recovery systems.

The liquid bath also acts as a heat absorber, actively cooling the gas throughout compression.

Furthermore, the sealing liquid is cooled to maintain near-isothermal compression within the system.

The liquid bath is also proficient at extracting fine particulate matter entrapped in the flare gas. Liquid ring compressors are adept at tolerating minor amounts of free liquids in the incoming gas stream, potentially obviating the need for a suction knock-out.



# Our Products:



## Garro Single Stage Compressors

Single stage compressors deliver reliable, proven performance especially for Chemical and Petrochemical process applications.

With a discharge pressure up to 6 bar abs. (72 psig), GARO offers efficient, OEM compressors with low maintenance requirements.

With a suction capacity ranging from 100 to 5,000 m<sup>3</sup>/h (60 to 2,900 CFM), Single Stage models are indicated for demanding process applications like Chlorine, Vinyl Chloride Monomer (VCM), and Steamer Off Gas



## Garro Double Stage Compressors

**GARO Two Stage** compressors deliver reliable, proven performance especially for Oil & Gas, Chemical and Petrochemical process applications.

With a discharge pressure up to 13 bar abs. (175 psig), GARO offers efficient, OEM compressors with low maintenance requirements.

With a suction capacity ranging from 100 to 4,000 m<sup>3</sup>/h (60 to 2,350 CFM), Double Stage models are indicated for demanding process applications like **Flare Gas Recovery**, or **Vapor Recovery**.



## Customized Packages

Our customized package solutions offer complete system designs and are built around the efficiency of **GARO liquid ring compressors**.

Providing compressor packages for refineries and chemical plants, Garo custom designs each solution to handle the most demanding oil & gas, chemical and petrochemical applications.

# Applications:

## Flare Gas Recovery



## Offshore Gas Compressors and Compression Packages



## Vapor Recovery Unit



## Dry and Wet Chlorine Compression



And more...

# Benefits of GARO Liquid Ring Compressor

---



01

Flare Gas Recovery System from Garo not only minimizes the release of toxic gases into the atmosphere, bolstering a facility's environmental credentials but also offers economic advantages for operators. FGR systems assist operators in recuperating valuable, high-heat gases for use as an in-house fuel source, as feedstock reuse, or as a saleable product from the facility.

02

GARO's liquid ring compressors excel in managing gases and vapors with high concentrations of H<sub>2</sub>S and/or CO<sub>2</sub>, as exemplified by GARO's patented Washing Amine Integrated System (WAIS), designed to scrub H<sub>2</sub>S and CO<sub>2</sub> to acceptable levels during standard compression cycles.

03

Compression is carried out within a liquid environment, typically involving water, which inherently ensures safety during the compression process. .

04

Liquid ring compressor systems are equipped to handle an array of gas compositions, including those that are dirty, explosive, and corrosive, as well as those prone to condensate formation at discharge.

05

Reliable and capable of operating at low speeds, liquid ring compressors contribute to noise and vibration reduction while demanding minimal maintenance. They can be constructed from diverse materials to align with specific customer application requirements.

# GARO® Customized & Packaged Solutions for EPC Companies

---



From the concept & FEED5. Before the products leave our study, we provide estimates and facility, we take all necessary tests, possible process reevaluation to including, if required, a complete help end-users and consultancy unit running test to demonstrate companies to choose the right the full integrity of the compression technology. package.



Before the products leave our facility, we take all necessary tests, including, if required, a complete unit running test to demonstrate the full integrity of the compression package.



During the project definition with EPC, we sustain the clients in the choice and comprehension of the best solutions. We are not suppliers; we are part of your team.



GARO Service & Support not only takes care of the erection, commissioning and start-up supervision of the system, but also trains the customer how to run the package.



In the detailed engineering phase, our qualified engineers design customized systems based on project requirements, to create a tailor made product.



We never forget our customers after the sale phase: guarantees and warranties are always included. Moreover, GARO Service & Support is always ready to help you to protect your investment by maintaining performance and reliability.



We take care of the package manufacturing choosing only the best suppliers and providing scrupulous quality controls.



An Ingersoll Rand Business



**GARO delivers a broad range of compressors and custom designed packages** to end-users and OEM customers worldwide.

**GARO provides reliable and efficient equipment** that is put to work in a multitude of demanding industrial process applications.

Garo products and systems serve industries including **Oil & Gas, Chemical, Petrochemical, and more.**

Strada Provinciale Cassanese, 108  
20052, Vignate (MI)

[www.garocompressors.com](http://www.garocompressors.com)



Please recycle after use.